



SLOVENSKI STANDARD
SIST ISO 7053:1996

01-april-1996

D`c Yj]bg_]j]U_]g`ýYgffcVc[`Uj c`g`_fUWwa

Hexagon washer head tapping screws

Vis à tôle à tête hexagonale à embase plate

ITEH STANDARD PREVIEW
(standards.iteh.ai)

Ta slovenski standard je istoveten z: ISO 7053:1992

[SIST ISO 7053:1996](https://standards.iteh.ai/catalog/standards/sist/9228c0fb-e5c2-4da7-a4de-1e1f4c93cdcd/sist-iso-7053-1996)

<https://standards.iteh.ai/catalog/standards/sist/9228c0fb-e5c2-4da7-a4de-1e1f4c93cdcd/sist-iso-7053-1996>

ICS:

21.060.10 Sorniki, vijaki, stebelni vijaki Bolts, screws, studs

SIST ISO 7053:1996

en

iTeh STANDARD PREVIEW
(standards.iteh.ai)

SIST ISO 7053:1996

<https://standards.iteh.ai/catalog/standards/sist/9228c0fb-e5c2-4da7-a4de-1e1f4c93cdcd/sist-iso-7053-1996>

INTERNATIONAL STANDARD

ISO
7053

First edition
1992-04-15

Hexagon washer head tapping screws

Vis à tôle à tête hexagonale à embase plate

iTeh STANDARD PREVIEW
(standards.iteh.ai)

SIST ISO 7053:1996

<https://standards.iteh.ai/catalog/standards/sist/9228c0fb-e5c2-4da7-a4de-1e1f4c93cdcd/sist-iso-7053-1996>



Reference number
ISO 7053:1992(E)

ISO 7053:1992(E)**Foreword**

ISO (the International Organization for Standardization) is a worldwide federation of national standards bodies (ISO member bodies). The work of preparing International Standards is normally carried out through ISO technical committees. Each member body interested in a subject for which a technical committee has been established has the right to be represented on that committee. International organizations, governmental and non-governmental, in liaison with ISO, also take part in the work. ISO collaborates closely with the International Electrotechnical Commission (IEC) on all matters of electrotechnical standardization.

Draft International Standards adopted by the technical committees are circulated to the member bodies for voting. Publication as an International Standard requires approval by at least 75 % of the member bodies casting a vote.

International Standard ISO 7053 was prepared by Technical Committee ISO/TC 2, *Fasteners*.

SIST ISO 7053:1996

<https://standards.iteh.ai/catalog/standards/sist/9228c0fb-e5c2-4da7-a4de-1e1f4c93cdcd/sist-iso-7053-1996>

© ISO 1992

All rights reserved. No part of this publication may be reproduced or utilized in any form or by any means, electronic or mechanical, including photocopying and microfilm, without permission in writing from the publisher.

International Organization for Standardization
Case Postale 56 • CH-1211 Genève 20 • Switzerland

Printed in Switzerland

Hexagon washer head tapping screws

iTeh STANDARD PREVIEW
(standards.iteh.ai)

1 Scope

This International Standard specifies hexagon washer head tapping screws with threads from ST2,2 up to and including ST8.

[SIST ISO 7053:1996](https://standards.iteh.ai/catalog/standards/sist/9228c0fb-e5c2-4da7-a4de-1e1f4c93cdcd/sist-iso-7053-1996)

2 Normative references

<https://standards.iteh.ai/catalog/standards/sist/9228c0fb-e5c2-4da7-a4de-1e1f4c93cdcd/sist-iso-7053-1996>

The following standards contain provisions which, through reference in this text, constitute provisions of this International Standard. At the time of publication, the editions indicated were valid. All standards are subject to revision, and parties to agreements based on this International Standard are encouraged to investigate the possibility of applying the most recent editions of the standards indicated below. Members of IEC and ISO maintain registers of currently valid International Standards.

ISO 1478:1983, *Tapping screws thread*.

ISO 2702:1992, *Heat-treated steel tapping screws — Mechanical properties*.

ISO 3269:1988, *Fasteners — Acceptance inspection*.

ISO 4042:1989, *Threaded components — Electroplated coatings*.

ISO 4759-1:1978, *Tolerances for fasteners — Part 1: Bolts, screws and nuts with thread diameters between 1,6 (inclusive) and 150 mm (inclusive) and product grades A, B and C*.

ISO 7053:1992(E)

3 Dimensions

See figure 1 and table 1.

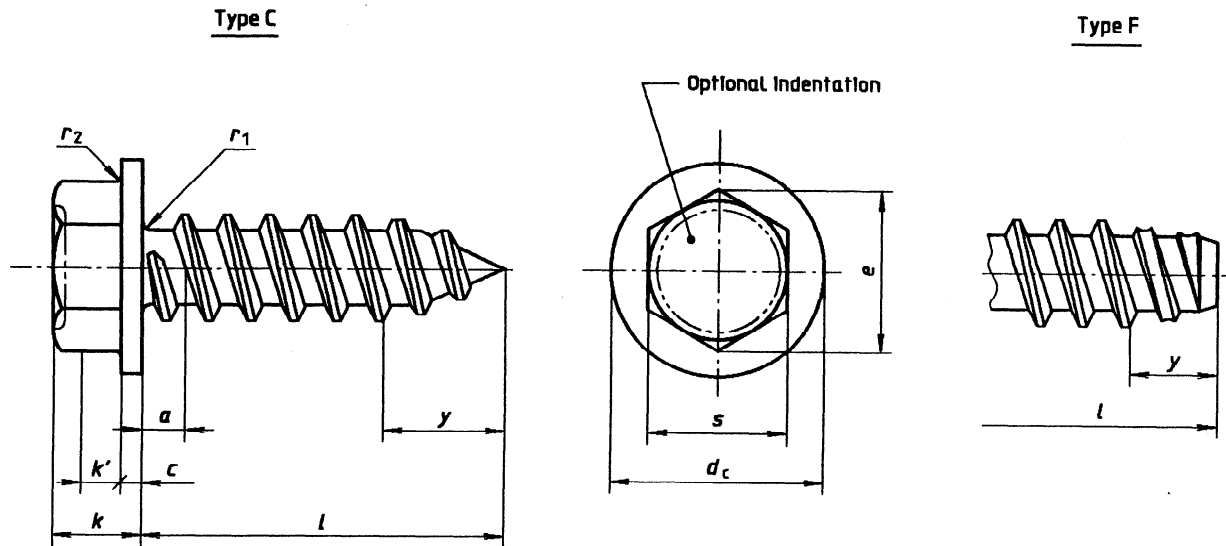

Figure 1

iTeh STANDARD PREVIEW
(standards.iteh.ai)

SIST ISO 7053:1996

<https://standards.iteh.ai/catalog/standards/sist/9228c0fb-e5c2-4da7-a4de-1e1f4c93cdcd/sist-iso-7053-1996>

Table 1

Dimensions in millimetres

Thread		ST2,2	ST2,9	ST3,5	ST3,9	ST4,2	ST4,8	ST5,5	ST6,3	ST8			
$P^{1)}$		0,8	1,1	1,3	1,3	1,4	1,6	1,8	1,8	2,1			
$a^{2)}$ max.		0,8	1,1	1,3	1,3	1,4	1,6	1,8	1,8	2,1			
d_c		max.	4,2	6,3	8,3	8,3	8,8	10,5	11	13,5	18,0		
		min.	3,8	5,8	7,6	7,6	8,1	9,8	10	12,2	16,7		
c min.		0,25	0,4	0,6	0,6	0,8	0,9	1	1	1,2			
s		nom. = max.	3,00	4,00	5,50	5,50	7,00	8,00	8,00	10,00	13,00		
		min.	2,86	3,82	5,32	5,32	6,78	7,78	7,78	9,78	12,73		
e min.		3,2	4,28	5,96	5,96	7,59	8,71	8,71	10,95	14,26			
k		nom. = max.	2,0	2,8	3,4	3,4	4,1	4,3	5,4	5,9	7,0		
		min.	1,7	2,5	3,0	3,0	3,6	3,8	4,8	5,3	6,4		
$k' ^{3)}$ min.		0,9	1,3	1,5	1,5	1,8	2,2	2,7	3,1	3,3			
r_1 max.		0,3	0,4	0,5	0,5	0,6	0,7	0,8	0,9	1,1			
r_2 max.		0,15	0,2	0,25	0,25	0,3	0,3	0,4	0,5	0,6			
$y^{4)}$		Type C ref.	2	2,6	3,2	3,5	3,7	4,3	5	6	7,5		
		Type F	1,6	2,1	2,5	2,7	2,8	3,2	3,6	3,6	4,2		
$l^{5)}$		Approximate mass, in kilograms per 1 000 pieces ($\rho = 7,85 \text{ kg/dm}^3$) (for information only)											
		nom.	Type C		Type F								
		min.	max.	min.	max.								
4,5	3,7	5,3	3,7	4,5	0,17	—	—	—	—	—	—	—	—
6,5	5,7	7,3	5,7	6,5	0,21	0,43	0,93	—	—	—	—	—	—
9,5	8,7	10,3	8,7	9,5	0,27	0,54	1,1	1,14	1,84	2,48	—	—	—
13	12,2	13,8	12,2	13,0	0,35	0,66	1,28	1,35	2,09	2,8	3,64	5,44	—
16	15,2	16,8	15,2	16,0	0,41	0,77	1,44	1,54	2,31	3,1	4,01	5,96	10,9
19	18,2	19,8	18,2	19,0	0,47	0,87	1,59	1,73	2,52	3,39	4,4	6,49	11,8
22	21,2	22,8	20,7	22,0			1,74	1,93	2,74	3,68	4,78	7,01	12,7
25	24,2	25,8	23,7	25,0				2,12	2,95	3,97	5,17	7,54	13,6
32	30,7	33,3	30,7	32,0						4,66	6,06	8,76	15,7
38	36,7	39,3	36,7	38,0							6,82	9,82	17,5
45	43,7	46,3	43,5	45,0								11,1	19,6
50	48,7	51,3	48,5	50,0								12	21,1

NOTE — Popular lengths are those between the stepped, continuous bold lines.

- 1) P = pitch of the thread
- 2) a = distance from the underside of the head to the first major diameter of the thread
- 3) k' = wrenching height
- 4) y = length of incomplete thread
- 5) Sizes with lengths marked with a dash (—) in the table shall not be manufactured.

4 Specifications and reference International Standards

See table 2.

Table 2

Material		Steel
Thread	International Standard	ISO 1478
Mechanical properties	International Standard	ISO 2702
Tolerances	Product grade	A
	International Standard	ISO 4759-1
Finish		Plain Requirements for electroplating are covered in ISO 4042.
Acceptability		Acceptance procedure is covered in ISO 3269.

5 Designation

Example for the designation of a hexagon washer head tapping screw, type C, with thread ST3,5 and nominal length $l = 16$ mm:

Tapping screw ISO 7053 - ST3,5 × 16 - C

[SIST ISO 7053:1996](https://standards.iteh.ai/catalog/standards/sist/9228c0fb-e5c2-4da7-a4de-1e1f4c93cdcd/sist-iso-7053-1996)

<https://standards.iteh.ai/catalog/standards/sist/9228c0fb-e5c2-4da7-a4de-1e1f4c93cdcd/sist-iso-7053-1996>