International Standard



7061

INTERNATIONAL ORGANIZATION FOR STANDARDIZATION • МЕЖДУНАРОДНАЯ ОРГАНИЗАЦИЯ ПО СТАНДАРТИЗАЦИИ • ORGANISATION INTERNATIONALE DE NORMALISATION

● Shipbuilding — Aluminium shore gangways for seagoing vessels

Construction navale — Planchons en aluminium pour navires de haute mer

First edition — 1983-08-01

iTeh STANDARD PREVIEW
(standards.iteh.ai)

ISO 7061:1983

<https://standards.iteh.ai/catalog/standards/sist/6551c98b-90b9-4438-b716-e3105fadf440/iso-7061-1983>

UDC 629.12.011.57

Ref. No. ISO 7061-1983 (E)

Descriptors : shipbuilding, embarkation devices, gangways, aluminium products, specifications, dimensions, construction, tests, designation, marking.

Price based on 8 pages

Foreword

ISO (the International Organization for Standardization) is a worldwide federation of national standards bodies (ISO member bodies). The work of developing International Standards is carried out through ISO technical committees. Every member body interested in a subject for which a technical committee has been authorized has the right to be represented on that committee. International organizations, governmental and non-governmental, in liaison with ISO, also take part in the work.

Draft International Standards adopted by the technical committees are circulated to the member bodies for approval before their acceptance as International Standards by the ISO Council.

International Standard ISO 7061 was developed by Technical Committee ISO/TC 8, *Shipbuilding and marine structures*, and was circulated to the member bodies in November 1981.

It has been approved by the member bodies of the following countries :

Austria	France	Poland
Belgium	India	Portugal
Brazil	Italy	Romania
China	Japan	Sweden
Czechoslovakia	Mexico	Thailand
Egypt, Arab Rep. of	Netherlands	United Kingdom

The member bodies of the following countries expressed disapproval of the document on technical grounds :

Germany, F. R.
Norway
USSR

Shipbuilding — Aluminium shore gangways for seagoing vessels

1 Scope

This International Standard specifies requirements for two types of aluminium shore gangway. The principal gangway specified is Type A, having 600 mm clear width. A lightweight gangway, Type B, having 380 mm clear width is specified in annex A. The method of test for initial sag and loaded deflection of the gangways is given in annex B.

NOTE — Users of this International Standard should note that, while observing the requirements of the standard, they should at the same time ensure compliance with any statutory requirements, rules and regulations as may be applicable to the individual ship concerned.

2 Field of application

2.1 These gangways are designed to be carried on board ship, to provide a lightweight, convenient and safe means of access from ship to shore, for use primarily by the ship's crew. The gangways may also be used for access from ship to ship when conditions are favourable.

2.2 These gangways are suitable for use horizontally or inclined up to an angle of 30° from the horizontal. For angles of inclination greater than 30°, special consideration of the design of treads and decking may be necessary.

2.3 These gangways are not intended to carry wheeled traffic such as loaded trolleys. This standard does not apply to gangways for ships for inland navigation.

3 References

ISO/R 209, *Composition of wrought products of aluminium and aluminium alloys — Chemical composition (per cent)*.

ISO 630, *Structural steels*.

ISO/R 827, *Mechanical property limits for extruded products of aluminium and aluminium alloys*.

ISO/R 828, *Mechanical property limits for rivet stock of aluminium and aluminium alloys*.

ISO 1175, *Shipbuilding — Dimensions and sectional properties of aluminium alloy sections for marine use*.

ISO 1181, *Three- or four-strand manila and sisal ropes*.

ISO 1346, *Three-strand (hawser-laid) and eight-strand (plaited) polypropylene monofilament or film ropes — Required characteristics*.

ISO 1459, *Metallic coatings — Protection against corrosion by hot dip galvanizing — Guiding principles*.

ISO 1460, *Metallic coatings — Hot dip galvanized coatings on ferrous materials — Determination of the mass per unit area — Gravimetric method*.

ISO 1461, *Metallic coatings — Hot dip galvanized coatings on fabricated ferrous products — Requirements*.

ISO 1835, *Short link chain for lifting purposes — Grade M(4), non-calibrated, for chain slings, etc.*

ISO/TR 2136, *Wrought aluminium and aluminium alloys — Rolled products — Mechanical properties*.

ISO 2408, *Steel wire ropes for general purposes — Characteristics*.

ISO 3799, *Textile machinery and accessories — Hydraulic lubricating fittings for textile machinery*.

4 Definitions

For the purposes of this International Standard, the following definitions apply :

4.1 gangway : A bridge structure to allow safe embarkation and disembarkation from ship to shore or access to another ship.

4.2 side stringers : The longitudinal strength members of the gangway to which the cross-members, stanchions, roller or wheels and the lifting lugs, etc. are attached.

4.3 cross-members : The parts that hold the side stringer in position, and provide support for the decking.

4.4 decking : Flat topped corrugated section or plate.

4.5 treads : Battens fitted proud of the decking or deck plate level to give better foot grip when the gangway is inclined from the horizontal position.

4.6 guard rails : Hand and intermediate guides, supported by stanchions to prevent people falling from the gangway.

5 Types of gangway

Type A : 600 mm clear width gangway (see figure 1).

Type B : 380 mm clear width gangway (see figure 2 and annex A).

Dimensions in millimetres

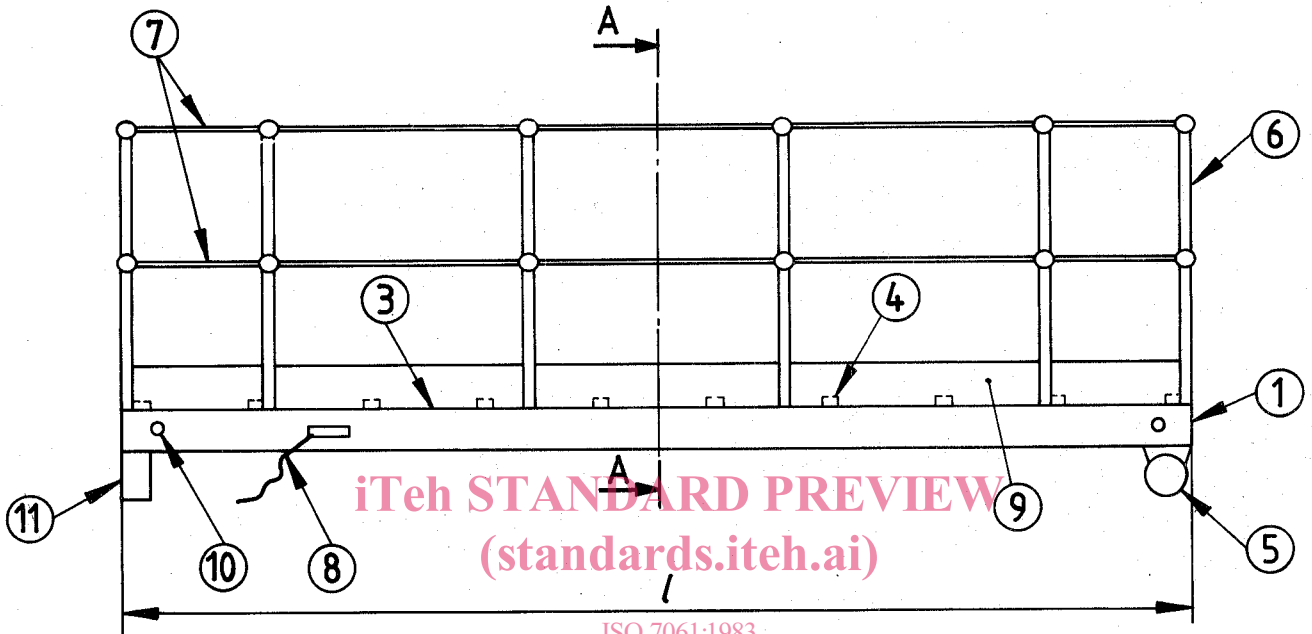

iTeh STANDARD PREVIEW
(standards.iteh.ai)
ISO 7061-1983
(see 7.1)
<https://standards.iteh.ai/catalog/standards/sist/6551c98b-90b9-4438-b716-e3105fadf440/iso-7061-1983>

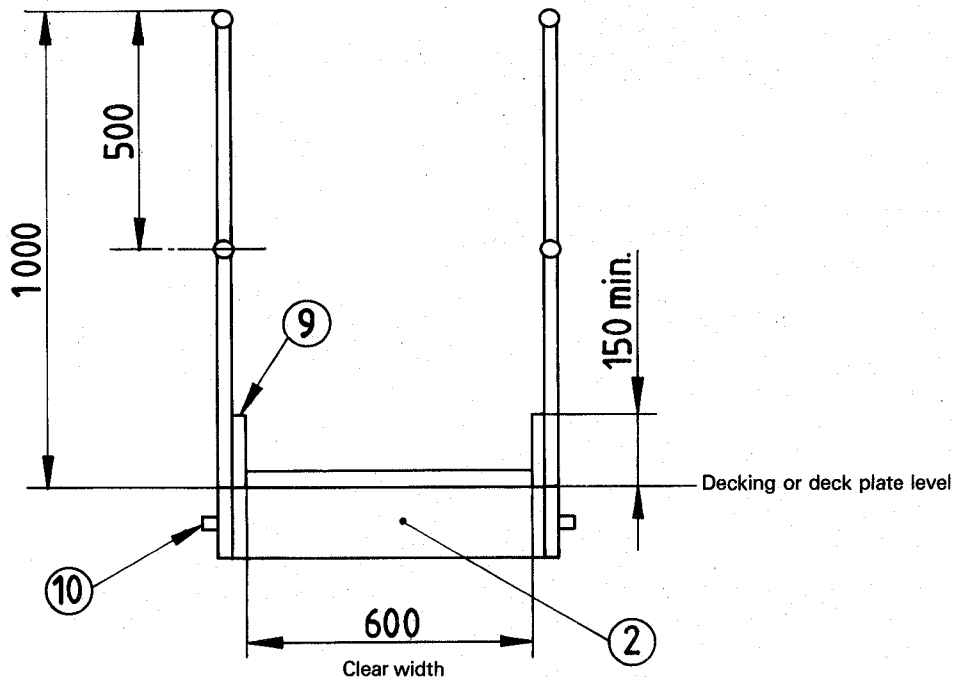

A-A

Figure 1 – General arrangement of Type A gangway (for item numbers, see the table)

6 Materials

The materials shall comply with the requirements of the table. Alternative materials may be used provided that they are at least as suitable in all respects for the intended duty and are equally acceptable to the purchaser.

Table — Materials

Item number ¹⁾	Component	Material	ISO number	Remarks
1	Side stringer	Aluminium alloy	ISO/R 209 ISO/R 827 ISO/R 828 ISO 1175 ISO/TR 2136	Al-Si 1 Mg
2	Cross-member	Aluminium alloy	ISO/R 209 ISO/R 828 ISO 1175 ISO/TR 2136	Al-Si 1 Mg
3	Decking or deck plate	Aluminium alloy	ISO/R 209 ISO/R 827 or ISO/TR 2136	Al-Si 1 Mg
4	Tread	Aluminium alloy	ISO/R 209 ISO/R 827	Al-Si Mg
5	Roller	Carbon steel with rubber or plastics sleeve ²⁾	ISO 630	Grade Fe 44A
	Wheel	Carbon steel with solid tyre of rubber or plastics ²⁾		
6	Stanchion	Aluminium alloy	ISO/R 209 ISO/R 827	Al-Si 1 Mg
		Carbon steel	ISO 630	Grade Fe 44A (galvanized)
7	Guard rail : Rigid rail	Aluminium section	ISO/R 287	See 8.9
	Fibre rope	Sisal or manila	ISO 1181	
		Polypropylene monofilament or film rope	ISO 1346	See 8.9
	Chain	Steel	ISO 1835	Galvanized
Wire rope, plastic coated	PVC coated guard-wire rope	ISO 2408	Plastic coated	
8	Securing device	Sisal or manila	ISO 1181	
		Polypropylene monofilament or film rope	ISO 1346	See 8.12
9	Toeboard	Aluminium alloy	ISO/R 209	Al-Si 1 Mg
		Hardwood	—	
10	Lifting lug	Aluminium alloy	ISO/R 209 ISO/TR 2136	Al-Si 1 Mg
11	Anti-slip lug	Aluminium alloy	ISO/R 209 ISO/TR 2136	Al-Si 1 Mg

1) The item numbers in this table refer to component parts in figures 1 and 2.

2) The sleeve or tyre may have a ribbed or flat surface.

7 Dimensions

7.1 Type A gangways

Dimensions shall be in accordance with figure 1. The minimum overall length, l , shall be 2 m, with increments of approximately 0,5 m up to a length of 9 m, after which the increments shall be approximately 1 m.

7.2 Type B gangways

Dimensions shall be in accordance with figure 2. The maximum overall length, l , shall be 4 m, with decrements of approximately 0,5 m.

8 Design and construction

8.1 General design features

8.1.1 The manufacturer of the gangway shall be informed of any unusual or hazardous conditions affecting the design of the gangway.

8.1.2 Direct contact between dissimilar metals shall be avoided to prevent galvanic corrosion.

8.1.3 Where the gangway is for use on tankers or ships carrying flammable cargo, it shall be provided with an effective and marked earthing device, and shall be suitably surface coated to prevent sparking.

8.2 Design loading

The assembled gangway shall be designed to withstand a uniform decking load of 4 000 N/m², applied to the decking and treads whilst the gangway is in a horizontal position.

8.3 Factor of safety

The allowable stress used in the design of the gangway under the design loading of 8.2 shall be determined by applying a factor of safety of 2 on the 0,2 % proof stress of the aluminium alloy used.

8.4 Side stringers

Side stringers shall be constructed from extruded hollow section, rolled section, plate material or any combination of these.

8.5 Cross-members

Cross-members attached to the side stringers shall be arranged to support the decking, and shall be of bar, angle or hollow sections.

8.6 Decking

The decking shall comprise either continuous flat-topped longitudinal corrugated section, or individual flat plate section, which may have a non-slip coating applied between the treads.

8.7 Treads

Treads shall be of aluminium bar or rectangular hollow section, or of hardwood, and shall be spaced at regular intervals of 300 mm to 400 mm longitudinally.

They shall be securely fitted, and shall extend over the full gangway width between toeboards with the exception of a 25 mm cleaning gap at each end.

Treads shall have a minimum height of 30 mm above the decking; hardwood treads shall have a minimum section width of 40 mm in contact with the decking.

8.8 Stanchions

Stanchions shall be constructed from carbon steel or aluminium to comply with figures 1 or 2. They shall be fitted at regular intervals along the gangway, with a maximum permitted interval of 1 500 mm. Stanchions and associated hand guides shall be designed for a side loading at the upper guide level of 500 N/m, without permanent deformation to stanchions or rigid hand guides when used. Stanchions of one of the following types may be fitted :

- a) permanently fixed;
- b) hinged, with provision made to prevent inadvertent collapse;
- c) portable, with securing device to prevent accidental displacement from the socket or base support.

Galvanized stanchions, where specified, shall comply with the requirements of ISO 1459, ISO 1460 and ISO 1461.

8.9 Hand and intermediate guides

Hand and intermediate guides shall be provided to comply with figures 1 and 2 and shall be selected from one of the following types :

- a) continuous and adequately tensioned sisal, manila, polypropylene or plastic covered wire rope, having a minimum rope diameter of 16 mm;
- b) galvanized steel chain provided with adequate means of tensioning;
- c) continuous rigid aluminium solid or hollow section.

Polypropylene ropes shall be certified effective against actinic degradation for two years exposure in tropical conditions.

8.10 Toeboards

Toeboards shall be fitted to each side of the gangway to a minimum height of 150 mm.

8.11 Roller or wheels

A roller or wheels of 100 mm minimum outside diameter shall be positioned at one end of the gangway. Rollers and wheels shall be provided with self-lubricated bearings or fitted with lubrication nipples to ISO 3799 having a thread M10 × 1. To ensure protection of users' feet from movement of the gangway, roller or wheel guards shall be provided. At the maximum angle of use of the gangway there shall be no loss of contact between the roller or wheels and the contact surface.

8.12 Securing devices

Suitable attachments shall be provided on both sides of the gangway, in order to connect the securing devices (see figures 1 and 2).

8.13 Lifting lugs

The gangway shall be provided with four lifting lugs, securely attached to the stringers and positioned to produce a balanced lift.

8.14 Anti-slip lugs

The gangway shall be provided with anti-slip lugs securely attached to the stringers, and positioned to prevent the gangway slipping from its position on the bulwarks or other supporting structure.

9 Quality of manufacture

9.1 The assembly, comprising side stringers, cross-members, and decking, together with all ancillary fittings, shall be visibly free from defects and distortion.

9.2 All components shall be free from exposed rough or sharp edges likely to cause injury.

9.3 Care shall be taken in the preparation, riveting, bolting or welding of aluminium structures to ensure that the permissible design stresses are not exceeded.

9.4 The requirements of 8.1 shall be verified where applicable.

10 Acceptance tests

The following tests shall be carried out at the manufacturer's works :

10.1 Type test

One gangway of each length and type shall be tested by the method given in annex B, and a test certificate made available to the purchaser on request.

The deflection due to loading shall not exceed a value of $\frac{\text{overall length}}{75}$

10.2 Individual test

Each gangway shall be fully assembled with all fittings, and subjected to the following tests.

10.2.1 Lifting

The gangway shall be lifted by means of the lifting lugs provided. After the test there shall be no evidence of strain to the lugs or the adjacent structure.

10.2.2 Initial sag

The gangway shall be tested by the method given in clause B.1 of annex B. The initial sag shall be no greater than that recorded for the type test.

11 Marking

Each gangway shall be permanently marked by means of a rating plate prominently displayed. The rating plate shall contain such information as is relevant to the gangway, including the following :

- a) manufacturer's name or trade mark;
- b) type number and serial number;
- c) number of this International Standard, i.e. ISO 7061;
- d) type of gangway, i.e. A or B;
- e) overall length;
- f) maximum permitted angle of use;
- g) design loading.

12 Inspection

12.1 Gangways subjected to a type test shall be inspected to ensure that there are no signs of residual weakness or damage.

12.2 All gangways shall be visually checked after testing to ensure that :

- a) there is no distortion of the side stringers;
- b) the decking or deck plates are adequately secured;
- c) the roller or wheels revolve freely;
- d) if applicable, the stanchions, hand and intermediate guides can be easily erected in position;
- e) removable fittings for rigid joints can be properly stowed when the gangway is dismantled;
- f) the rating plate is affixed and correct.

13 Designation

A gangway conforming to this International Standard shall be designated as follows, in the order given :

- a) description : gangway;
- b) number of this International Standard : ISO 7061;
- c) type of gangway : A or B;

- d) overall length in metres;
- e) maximum permitted angle of use in degrees.

Example :

The designation of an aluminium shore gangway Type A of overall length 9 m, limited to 30° angle of use, is :

Gangway ISO 7061-A9-30

iTeh STANDARD PREVIEW
(standards.iteh.ai)

ISO 7061:1983

<https://standards.iteh.ai/catalog/standards/sist/6551c98b-90b9-4438-b716-e3105fadf440/iso-7061-1983>

Annex A

Type B — 380 mm clear width gangway

(This annex forms an integral part of the standard.)

The Type B gangway is a small lightweight gangway that can be manhandled into position for the quick disembarkation of a small number of persons when a ship first secures alongside. It is considered only as a "first person ashore" gangway.

Dimensions shall conform to figure 2 and 7.2. Design, construction and test shall be otherwise as for Type A gangways.

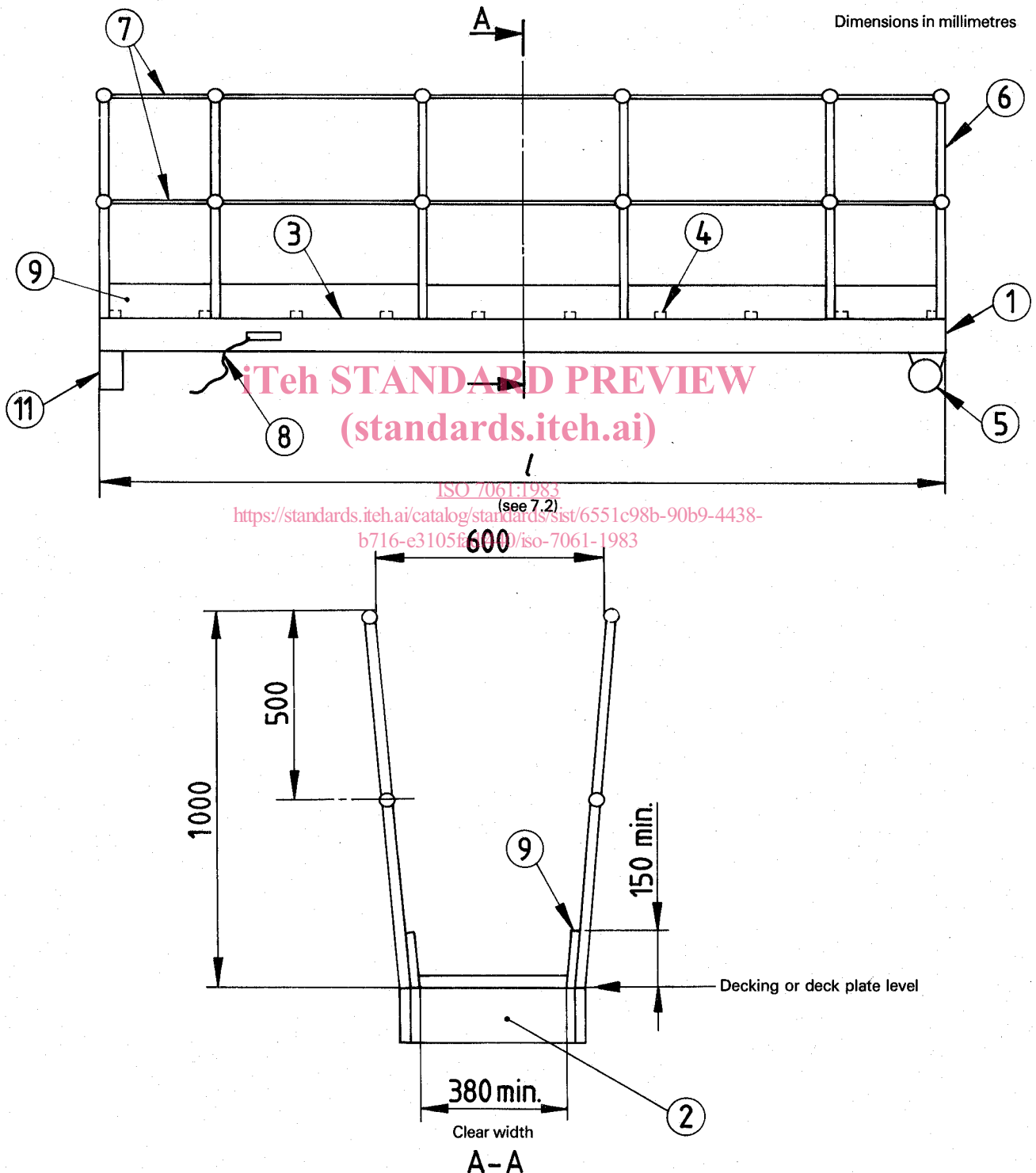

Figure 2 — General arrangement of Type B gangway (for item numbers, see the table)