**Mechanical and performance requirements
of case hardened and tempered metric
thread rolling screws**

*Caractéristiques mécaniques et fonctionnelles des vis autotaraudeuses par
déformation, à filetage métrique, cémentées et revenues*

iTeh STANDARD PREVIEW
(standards.iteh.ai)

ISO 7085:1999

[https://standards.iteh.ai/catalog/standards/sist/2a0fabd3-b0c6-410a-820d-
a96ccc3f0548/iso-7085-1999](https://standards.iteh.ai/catalog/standards/sist/2a0fabd3-b0c6-410a-820d-a96ccc3f0548/iso-7085-1999)



Contents	Page
1 Scope	1
2 Normative references	1
3 Materials	2
4 Mechanical properties	2
5 Test methods	4
6 Torque wrenches	7
7 Marking	7
Bibliography	8

iTeh STANDARD PREVIEW
(standards.iteh.ai)

[ISO 7085:1999](https://standards.iteh.ai/catalog/standards/sist/2a0fabd3-b0c6-410a-820d-a96ccc3f0548/iso-7085-1999)

<https://standards.iteh.ai/catalog/standards/sist/2a0fabd3-b0c6-410a-820d-a96ccc3f0548/iso-7085-1999>

© ISO 1999

All rights reserved. Unless otherwise specified, no part of this publication may be reproduced or utilized in any form or by any means, electronic or mechanical, including photocopying and microfilm, without permission in writing from the publisher.

International Organization for Standardization
Case postale 56 • CH-1211 Genève 20 • Switzerland
Internet iso@iso.ch

Printed in Switzerland

Foreword

ISO (the International Organization for Standardization) is a worldwide federation of national standards bodies (ISO member bodies). The work of preparing International Standards is normally carried out through ISO technical committees. Each member body interested in a subject for which a technical committee has been established has the right to be represented on that committee. International organizations, governmental and non-governmental, in liaison with ISO, also take part in the work. ISO collaborates closely with the International Electrotechnical Commission (IEC) on all matters of electrotechnical standardization.

International Standards are drafted in accordance with the rules given in the ISO/IEC Directives, Part 3.

Draft International Standards adopted by the technical committees are circulated to the member bodies for voting. Publication as an International Standard requires approval by at least 75 % of the member bodies casting a vote.

International Standard ISO 7085 was prepared by Technical Committee ISO/TC 2, *Fasteners*, Subcommittee 1, *Mechanical properties of fasteners*.

iTeh STANDARD PREVIEW (standards.iteh.ai)

[ISO 7085:1999](https://standards.iteh.ai/catalog/standards/sist/2a0fabd3-b0c6-410a-820d-a96ccc3f0548/iso-7085-1999)

<https://standards.iteh.ai/catalog/standards/sist/2a0fabd3-b0c6-410a-820d-a96ccc3f0548/iso-7085-1999>

iTeh STANDARD PREVIEW
(standards.iteh.ai)

ISO 7085:1999

<https://standards.iteh.ai/catalog/standards/sist/2a0fabd3-b0c6-410a-820d-a96ccc3f0548/iso-7085-1999>

Mechanical and performance requirements of case hardened and tempered metric thread rolling screws

1 Scope

This International Standard specifies the requirements for case hardened and tempered metric thread rolling screws. Thread rolling screws according to this International Standard produce female threads which fit ISO general purpose metric screw threads, in the range from 2 mm up to and including 12 mm nominal thread diameter, for use in general engineering applications.

ISO 898-1 is not applicable to screws made according to this International Standard.

2 Normative references

The following normative documents contain provisions which, through reference in this text, constitute provisions of this International Standard. For dated references, subsequent amendments to, or revisions of, any of these publications do not apply. However, parties to agreements based on this International Standard are encouraged to investigate the possibility of applying the most recent editions of the normative documents indicated below. For undated references, the latest edition of the normative document referred to applies. Members of ISO and IEC maintain registers of currently valid International Standards.

ISO 898-2:1992, *Mechanical properties of fasteners — Part 2: Nuts with specified proof load values — Coarse thread.*

ISO 965-3:1998, *ISO general purpose metric screw threads — Tolerances — Part 3: Deviations for constructional screw threads.*

ISO 4042:1999, *Fasteners — Electroplated coatings.*

ISO 5954:1998, *Cold-reduced carbon steel sheet according to hardness requirements.*

ISO 6507-1:1997, *Metallic materials — Vickers hardness test — Part 1: Test method.*

ISO 15330:1999, *Fasteners — Preloading test for the detection of hydrogen embrittlement — Parallel bearing surface method.*

3 Materials

The thread rolling screws shall be made from cold heading, case hardening quality steel; the chemical composition given in Table 1 is given for guidance only.

Table 1 — Chemical composition

Analysis	Composition limits % (m/m)	
	Carbon	Manganese
Ladle	0,15 to 0,25	0,70 to 1,65
Check	0,13 to 0,27	0,64 to 1,71

NOTE Boron content can reach 0,005 % provided that non-effective boron is controlled by addition of titanium and/or aluminium.

4 Mechanical properties

4.1 Survey

A survey of mechanical properties and of respective clauses for testing is given in Table 2.

Table 2 — Mechanical properties

Properties	Subclause/table	Test reference
Core hardness	4.3	5.1
Case hardness	4.3	5.2
Case depth	4.4 and Table 4	5.3
Torsional strength	4.5 and Table 3	5.4
Ductility	4.6	5.5
Driveability	4.7 and Table 3	5.6
Embrittlement	4.8	5.7
Core hardness after retempering	4.9	5.8
Tensile breaking load	4.10 and Table 3	5.9

4.2 Heat treatment

Finished screws shall be case hardened and tempered at a minimum tempering temperature of 340 °C in order to meet all the mechanical and performance requirements of this International Standard as detailed in Table 3.

4.3 Hardness

The core hardness shall be 290 HV 10 to 370 HV 10, and the case hardness shall be 450 HV 0,3 minimum.

4.4 Case depth

The case depth shall be as given in Table 4.

4.5 Breaking torque

The minimum breaking torque is specified in Table 3, when tested in accordance with 5.4. Failure shall not occur in the clamped threads.

4.6 Ductility

There shall be no fracture at the head/shank intersection when a permanent deformation of 7° is induced between the plane of the underhead bearing face and a plane normal to the axis of the screw, when tested in accordance with 5.5. The test shall be regarded as satisfactory even if a crack appears in the first thread, provided that the head does not snap off.

4.7 Ability to form the mating thread

The screw shall, without permanent deformation of its own thread when viewed at × 10 magnification, form a mating thread in a test plate in accordance with 5.6. During the driveability test the drive torque shall not exceed the maximum values specified in Table 3.

The thread formed by the screw in the test plate shall be capable of accepting a fastener threaded in accordance with ISO 965-3, tolerance class 6h and shall resist a proof load test in accordance with ISO 898-2, property class 8.

Table 3 — Mechanical and performance requirements

Nominal thread diameter mm	Breaking torque	Drive torque	Tensile breaking load ^a
	min. Nm	max. Nm	min. N
2,0	0,5	0,3	1 940
2,5	1,2	0,6	3 150
3,0	2,1	1,1	4 680
3,5	3,4	1,7	6 300
4,0	4,9	2,5	8 170
5,0	10,0	5,0	13 200
6,0	17,0	8,5	18 700
8,0	42,0	21,0	34 000
10,0	85,0	43,0	53 900
12,0	150,0	75,0	78 400

^a For information only.

Table 4 — Case Depth

Values in millimetres

Nominal thread diameter	Case depth	
	min.	max.
2 and 2,5	0,04	0,12
3 and 3,5	0,05	0,18
4 and 5	0,10	0,25
6 and 8	0,15	0,28
10 and 12	0,15	0,32

4.8 Embrittlement

For thread rolling screws there is a risk of failure due to hydrogen embrittlement, especially if they are electroplated. Therefore, process investigation shall be conducted using a test to detect hydrogen embrittlement, by the "Parallel bearing surface method" according to ISO 15330 in order to be sure that the process with regard to embrittlement is under control. If embrittlement is discovered, modification of the manufacturing process will be necessary.

In the case of electroplating, hydrogen embrittlement relief treatment in accordance with ISO 4042 shall be applied.

NOTE Non-electrolytic applied coatings, e.g. in accordance with ISO 10683, are preferred.

4.9 Core hardness after retempering

The reduction in core hardness after retempering in accordance with the test procedure described in 5.8 shall not exceed 20 HV.

4.10 Tensile breaking load

Tensile testing for screws having lengths equal to or longer than 12 mm or 3 times the nominal thread diameter may be carried out by agreement between the purchaser and the supplier.

NOTE The minimum tensile breaking loads in Table 3 are given for information only.

iTeh STANDARD PREVIEW (standards.iteh.ai)

5 Test methods

5.1 Core hardness test

[ISO 7085:1999](https://standards.iteh.ai/catalog/standards/sist/2a0fabd3-b0c6-410a-820d-)

<https://standards.iteh.ai/catalog/standards/sist/2a0fabd3-b0c6-410a-820d->

Core hardness shall be determined at the mid-radius of a transverse section through the screw taken at a distance sufficiently behind the point of the screw to be through the full minor diameter. The test shall comply with ISO 6507-1.

5.2 Case hardness test

For routine control purposes (where case depth and geometry of the screw permit), case hardness may be measured on end, shank or head using the Vickers hardness test in accordance with ISO 6507-1 (see Figure 1). Hardness tests shall be made on screws with surface coatings after the removal of the coating.

For refereeing purposes, a micro-hardness instrument with a Vickers indenter and a HV 0,1 load shall be used for screws with nominal diameters ≥ 4 mm. In such cases, measurements shall be made on the thread profile of a suitably prepared longitudinal cross section and at a distance of at least 0,05 mm from the edge of the specimen. For nominal thread diameters < 4 mm the test conditions shall be agreed.

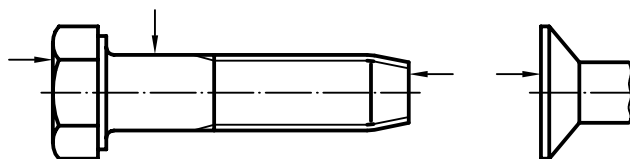
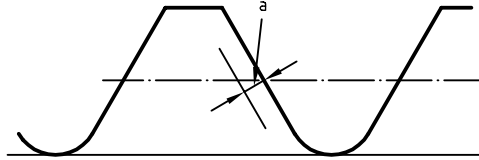

Figure 1 — Places where the case hardness may be measured

5.3 Case depth test

The case depth is the distance, perpendicular to the surface, from the surface to the point at which the hardness is 30 HV 0,3 above the actual core hardness.

For refereeing purposes, a micro-hardness plot shall be made using a Vickers indenter and a HV 0,3 load on a suitably prepared metallographic specimen (see Figure 2).



^a Only if the thread form is not totally carburized.

Figure 2 — Place where the case depth may be measured

5.4 Torsional test

The sample screw shall be securely clamped by suitable means (see Figure 3) with at least two full threads projecting above the clamping device, and at least two full threads exclusive of point, held within the clamping device.

By means of a suitably calibrated measuring device, torque shall be applied to the screw until failure of the screw occurs. The torque required to cause failure shall be recorded as the breaking torque and shall be equal to or exceed the minimum breaking torque specified in Table 3.

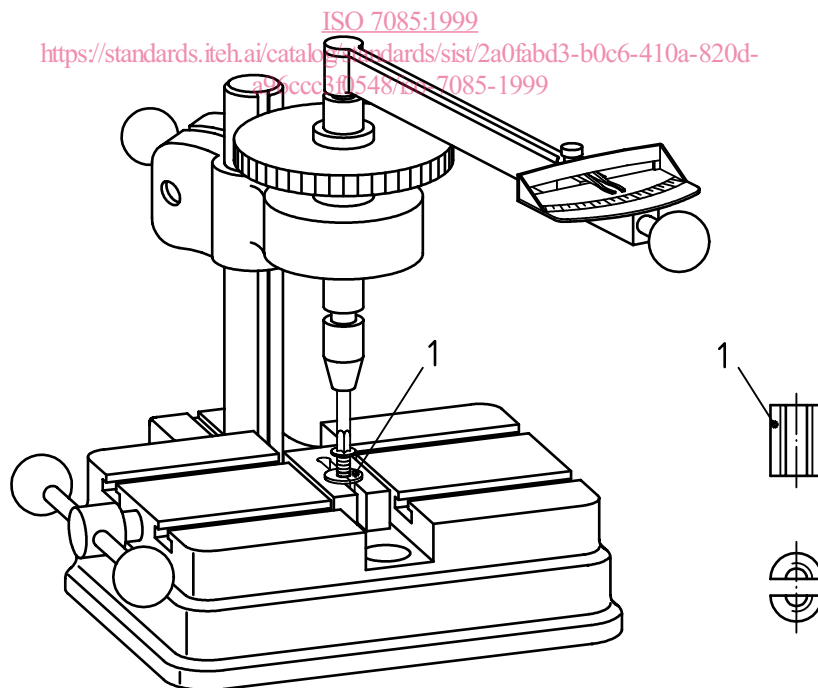

Key

1 Split threaded insert

Figure 3 — Typical test device for the torsional test