

INTERNATIONAL STANDARD

ISO
7171

First edition
1988-06-01



INTERNATIONAL ORGANIZATION FOR STANDARDIZATION
ORGANISATION INTERNATIONALE DE NORMALISATION
МЕЖДУНАРОДНАЯ ОРГАНИЗАЦИЯ ПО СТАНДАРТИЗАЦИИ

Furniture — Storage units — Determination of stability

Ameublement — Éléments de rangement — Détermination de la stabilité

ITeC STANDARD PREVIEW
(standards.iteh.ai)

[ISO 7171:1988](https://standards.iteh.ai/catalog/standards/sist/947a760d-a91f-4d15-8542-6a61dae809a8/iso-7171-1988)

<https://standards.iteh.ai/catalog/standards/sist/947a760d-a91f-4d15-8542-6a61dae809a8/iso-7171-1988>

Reference number
ISO 7171:1988 (E)

Foreword

ISO (the International Organization for Standardization) is a worldwide federation of national standards bodies (ISO member bodies). The work of preparing International Standards is normally carried out through ISO technical committees. Each member body interested in a subject for which a technical committee has been established has the right to be represented on that committee. International organizations, governmental and non-governmental, in liaison with ISO, also take part in the work. ISO collaborates closely with the International Electrotechnical Commission (IEC) on all matters of electrotechnical standardization.

Draft International Standards adopted by the technical committees are circulated to the member bodies for approval before their acceptance as International Standards by the ISO Council. They are approved in accordance with ISO procedures requiring at least 75 % approval by the member bodies voting.

International Standard ISO 7171 was prepared by Technical Committee ISO/TC 136, *Furniture*.

[ISO 7171:1988](https://standards.iteh.ai/catalog/standards/sist/947a760d-a91f-4d15-8542-)

<https://standards.iteh.ai/catalog/standards/sist/947a760d-a91f-4d15-8542->

Users should note that all International Standards undergo revision from time to time and that any reference made herein to any other International Standard implies its latest edition, unless otherwise stated.

© International Organization for Standardization, 1988 ●

Printed in Switzerland

© International Organization for Standardization, 1988 ●

Printed in Switzerland

Contents

	Page
0 Introduction	1
1 Scope and field of application	1
2 Definition	1
3 Test equipment and conditions	1
4 Stability of unloaded unit	1
5 Stability with loads on movable parts (vertical force)	1
6 Stability with loads on open shelf (vertical and horizontal forces)	3
7 Test report	3

iTeh STANDARD PREVIEW
(standards.iteh.ai)

[ISO 7171:1988](https://standards.iteh.ai/catalog/standards/sist/947a760d-a91f-4d15-8542-6a61dae809a8/iso-7171-1988)

<https://standards.iteh.ai/catalog/standards/sist/947a760d-a91f-4d15-8542-6a61dae809a8/iso-7171-1988>

iTeh STANDARD PREVIEW
(standards.iteh.ai)

This page intentionally left blank

[ISO 7171:1988](#)

<https://standards.iteh.ai/catalog/standards/sist/947a760d-a91f-4d15-8542-6a61dae809a8/iso-7171-1988>

Furniture — Storage units — Determination of stability

0 Introduction

This International Standard is one of a series being prepared on the strength, durability and stability of furniture. The series currently consists of the following:

ISO 7170, *Furniture — Storage units — Determination of strength and durability.*

ISO 7171, *Furniture — Storage units — Determination of stability.*

ISO 7172, *Furniture — Tables — Determination of stability.*

ISO 7173, *Furniture — Chairs and stools — Determination of strength and durability.*

ISO 7174-1, *Furniture — Chairs — Determination of stability — Part 1: Upright chairs and stools.*

ISO 7174-2, *Furniture — Chairs — Determination of stability — Part 2: Chairs with tilting or reclining mechanism.*

ISO 8019, *Furniture — Tables — Determination of strength and durability.*

1 Scope and field of application

This International Standard describes methods for determining the stability of free-standing storage furniture, including cupboards, cabinets and bookshelves, that are fully assembled and ready for use.

The tests are not applicable to wall-mounted or otherwise built-in units.

The test results are only valid for the article tested. When the test results are intended to be applied to other similar articles, the test specimen should be representative of the production model.

In the case of designs not covered by the test procedures, the test should be carried out as far as possible as described, and a list made of the deviations from the test procedure.

2 Definition

stability: Ability to withstand forces that tend to cause the article to overturn.

3 Test equipment and conditions

3.1 Vertical force application device, which can apply a vertical force, either at a given value or a gradually increasing value. The device shall not hinder movement of the article being tested. If a given value is wanted, the device may consist of a mass, e.g. a steel plate.

3.2 Horizontal force application device, for example spring gauge, which can apply a gradually increasing horizontal force to a shelf.

3.3 Stops, to prevent the article from sliding but not overturning, no higher than 12 mm except in cases where the design of the item necessitates the use of higher stops, in which case the lowest that will prevent the item from sliding shall be used.

3.4 Floor surface, horizontal, flat.

3.5 Tolerances, unless otherwise stated, are as follows:

Forces $\pm 5\%$

Masses $\pm 0,5\%$

Dimensions $\pm 0,5\text{ mm}$

3.6 Preliminary preparation shall be to tighten any assembly fittings before testing.

4 Stability of unloaded unit

Position the storage unit on the floor with stops against the front legs or plinth.

Open all doors to 90° and extend all drawers and extension leaves to two-thirds of their sliding length. Open flaps to their horizontal position or as near horizontal as possible.

With all components as above, register any tilting tendencies.

5 Stability with loads on movable parts (vertical force) (see figures 1, 2 and 3)

Position the storage units on the floor with stops against the front legs or plinth.

Shelves, etc. shall be unloaded.

One part after another shall be opened/extended as in clause 4, tested as follows and then closed. Parts not undergoing test shall be closed. In the case of double doors, first one door shall be opened to 90° and tested, and then, with the first door still in the open position, the second door shall be opened to 90° and tested.

Apply a vertical force on the part undergoing test and increase the force until at least one of the opposite legs or part of the plinth just lifts away from the floor.

Apply the force with its centre positioned

- on doors: 50 mm from the outer edge (see figure 1);
- on drawers: over the centre of the front of the drawer (see figure 2);
- on flaps, leaves and shelves: over the centre and 50 mm from outer edge (see figure 3).

Record the force, in newtons, to the nearest whole number.

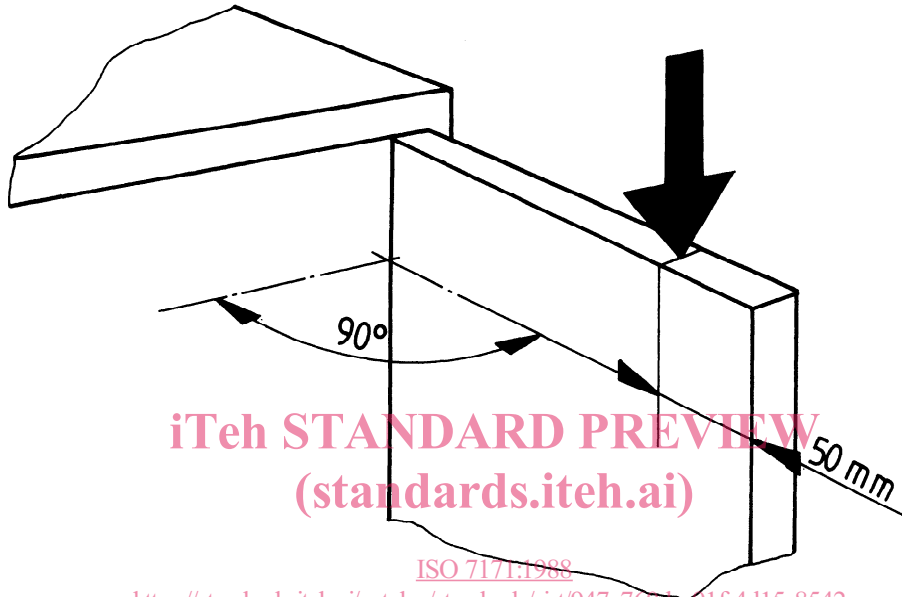

<https://standards.iteh.ai/catalog/standards/sist/947a760d-a91f-4d15-8542-6a61dae809a8/iso-7171-1988>

Figure 1 – Application of vertical force on the door

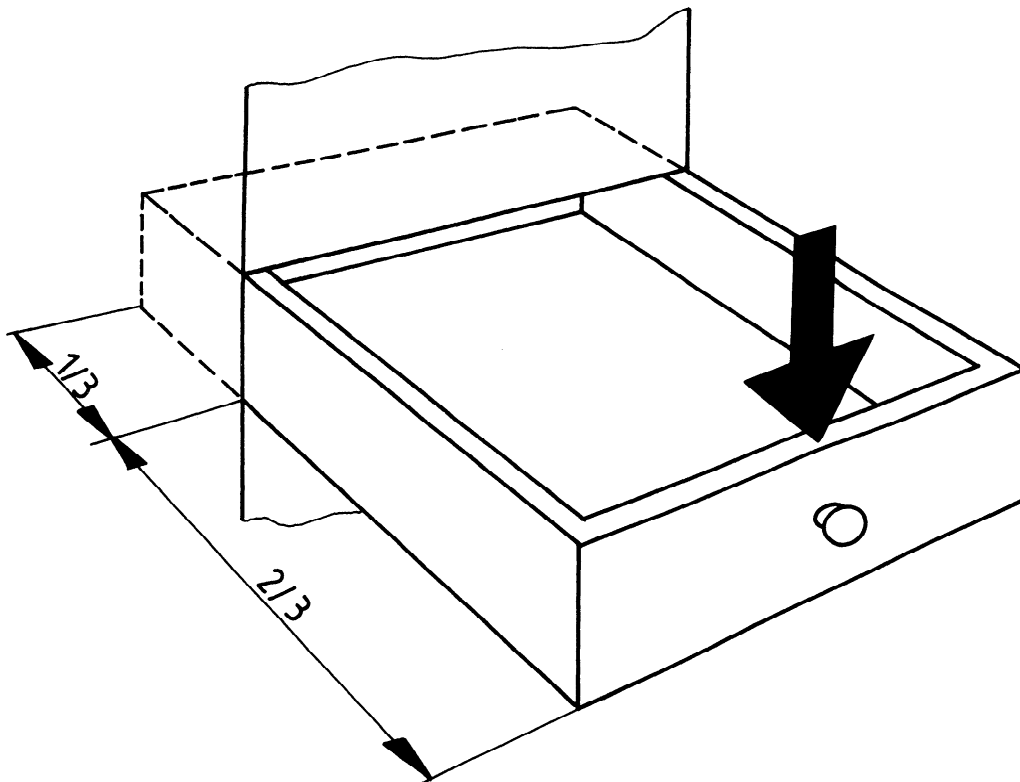

Figure 2 – Application of vertical force on the drawer

6 Stability with loads on open shelf (vertical and horizontal forces) (see figure 3)

Position the storage units on the floor with stops against the front legs or plinth.

With all doors, drawers, etc. closed, apply a vertical force of 50 N to an accessible shelf, 50 mm from its front edge. The shelf shall be the one where the lowest stability value is expected. The other shelves, etc. shall be unloaded.

Apply a horizontal force outwards from the shelf and increase the force until at least one of the opposite legs or part of the plinth just lifts away from the floor.

Record the force, in newtons, to the nearest whole number.

7 Test report

The test report shall include at least the following information :

- a) a reference to this International Standard;
- b) the piece of furniture tested (relevant data);
- c) stability of the unloaded unit (tilting/not tilting);
- d) stability with loads on movable parts, in newtons, from clause 5;
- e) stability with loads on open shelves expressed as in d), and which of the shelves were tested;
- f) details of any deviations from this International Standard;
- g) the name and address of the test facility;
- h) the date of test.

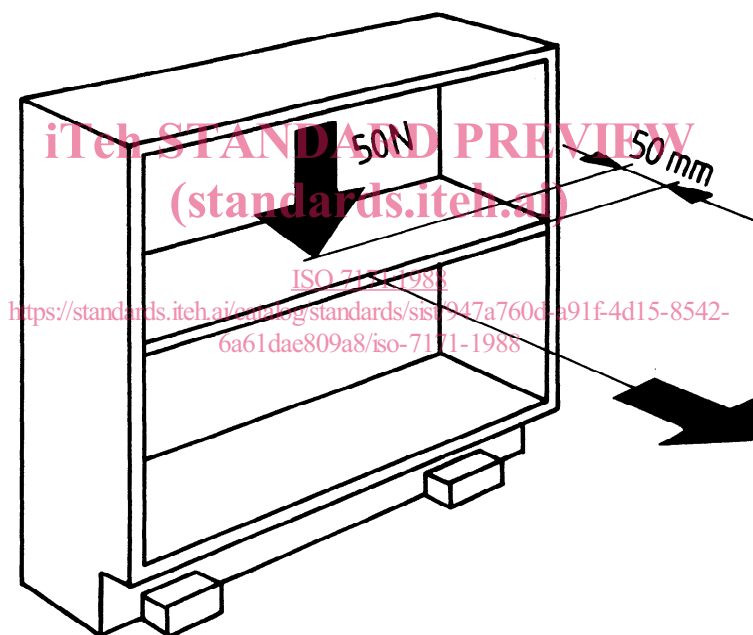

Figure 3 — Application of vertical and horizontal forces on the shelf

iTeh STANDARD PREVIEW
(standards.iteh.ai)

[ISO 7171:1988](#)

<https://standards.iteh.ai/catalog/standards/sist/947a760d-a91f-4d15-8542-6a61dae809a8/iso-7171-1988>

UDC 645.45 : 614.822

Descriptors: furniture, storage furniture, tests, stability tests.

Price based on 3 pages
