

INTERNATIONAL STANDARD

ISO
7175-2

First edition
1988-08-01



INTERNATIONAL ORGANIZATION FOR STANDARDIZATION
ORGANISATION INTERNATIONALE DE NORMALISATION
МЕЖДУНАРОДНАЯ ОРГАНИЗАЦИЯ ПО СТАНДАРТИЗАЦИИ

Furniture — Children's cots — Safety requirements and testing —

Part 2:

Test methods **iTeh STANDARD PREVIEW**
(standards.iteh.ai)

Ameublement — Lits d'enfants — Exigences de sécurité et essais —

[ISO 7175-2:1988](#)

Partie 2: Méthodes d'essai

<https://standards.iteh.ai/catalog/standards/sist/220691fb-14f6-4361-bbed-df5300e99690/iso-7175-2-1988>

Foreword

ISO (the International Organization for Standardization) is a worldwide federation of national standards bodies (ISO member bodies). The work of preparing International Standards is normally carried out through ISO technical committees. Each member body interested in a subject for which a technical committee has been established has the right to be represented on that committee. International organizations, governmental and non-governmental, in liaison with ISO, also take part in the work. ISO collaborates closely with the International Electrotechnical Commission (IEC) on all matters of electrotechnical standardization.

Draft International Standards adopted by the technical committees are circulated to the member bodies for approval before their acceptance as International Standards by the ISO Council. They are approved in accordance with ISO procedures requiring at least 75 % approval by the member bodies voting.

International Standard ISO 7175-2 was prepared by Technical Committee ISO/TC 136, *Furniture*.

ISO 7175-2:1988

Users should note that all International Standards undergo revision from time to time and that any reference made herein to any other International Standard implies its latest edition, unless otherwise stated.

Contents

	Page
0 Introduction	1
1 Scope and field of application	1
2 References	1
3 General test requirements	1
4 Test equipment	1
5 Test procedures	3
6 Test report	8

iTeh STANDARD PREVIEW
(standards.iteh.ai)

ISO 7175-2:1988

<https://standards.iteh.ai/catalog/standards/sist/220691fb-14f6-4361-bbed-df5300e99690/iso-7175-2-1988>

iTeh STANDARD PREVIEW
(standards.iteh.ai)

ISO 7175-2:1988

<https://standards.iteh.ai/catalog/standards/sist/220691fb-14f6-4361-bbed-df5300e99690/iso-7175-2-1988>

Furniture — Children's cots — Safety requirements and testing —

Part 2: Test methods

0 Introduction

This part of ISO 7175 has been prepared in order to provide assurance that cots complying with the requirements in part 1 are reasonably safe.

It describes a number of tests consisting of the application, to various parts of the item, of loads or forces simulating normal functional use, as well as misuse that can reasonably be expected to occur.

The tests are designed to evaluate properties without regard to materials, design/construction or manufacturing processes.

1 Scope and field of application

This part of ISO 7175 specifies test methods that assess the safety of children's cots for domestic use.

It applies to cots with an internal length between 900 and 1 400 mm that are designed to prevent the child from climbing out. It does not apply to rocking and swinging cots.

The tests are designed to be applied to a cot that is fully assembled and ready for use.

The test results are only valid for the article tested. When the test results are intended to be applied to other similar articles, the test specimen should be representative of the production model.

In the case of designs not catered for in the test procedures, the test should be carried out as far as possible as described, and a list made of the deviations from the test procedure.

2 References

ISO 48, *Vulcanized rubbers — Determination of hardness (Hardness between 30 and 85 IRHD)*.

ISO 554, *Standard atmospheres for conditioning and/or testing — Specifications*.

ISO 1521, *Paints and varnishes — Determination of resistance to water — Water immersion method*.

ISO 2439, *Polymeric materials, cellular flexible — Determination of hardness (indentation technique)*.

ISO 4628-3, *Paints and varnishes — Evaluation of degradation of paint coatings — Designation of intensity, quantity and size of common types of defect — Part 3 : Designation of degree of rusting*.

3 General test requirements

For tolerances, all forces shall have an accuracy of $\pm 5\%$, all masses an accuracy of $\pm 0,5\%$ and all dimensions an accuracy of $\pm 0,5$ mm.

Before any of the tests described in this part of ISO 7175 are commenced, the item shall be old enough to ensure that it has developed its full strength. At least four weeks in normal indoor conditions shall have elapsed between manufacture and testing in the case of glued joints in timber and the like.

Immediately before testing, the cot shall be stored for at least one week in a standardized atmosphere with a temperature of 23 ± 2 °C and a relative humidity of $(50 \pm 5)\%$ according to ISO 554.

The furniture shall be tested as delivered. If of knock-down type, it shall be assembled according to instructions supplied with the furniture. If the furniture can be assembled or combined in different ways, the most adverse combination shall be used for each test.

Knock-down fittings shall be tightened before testing.

4 Test equipment

The test forces may be applied by any suitable device, because results are dependent only upon correctly applied forces and loads, and not upon the apparatus. This does not however apply to items 4.2 and 4.5.

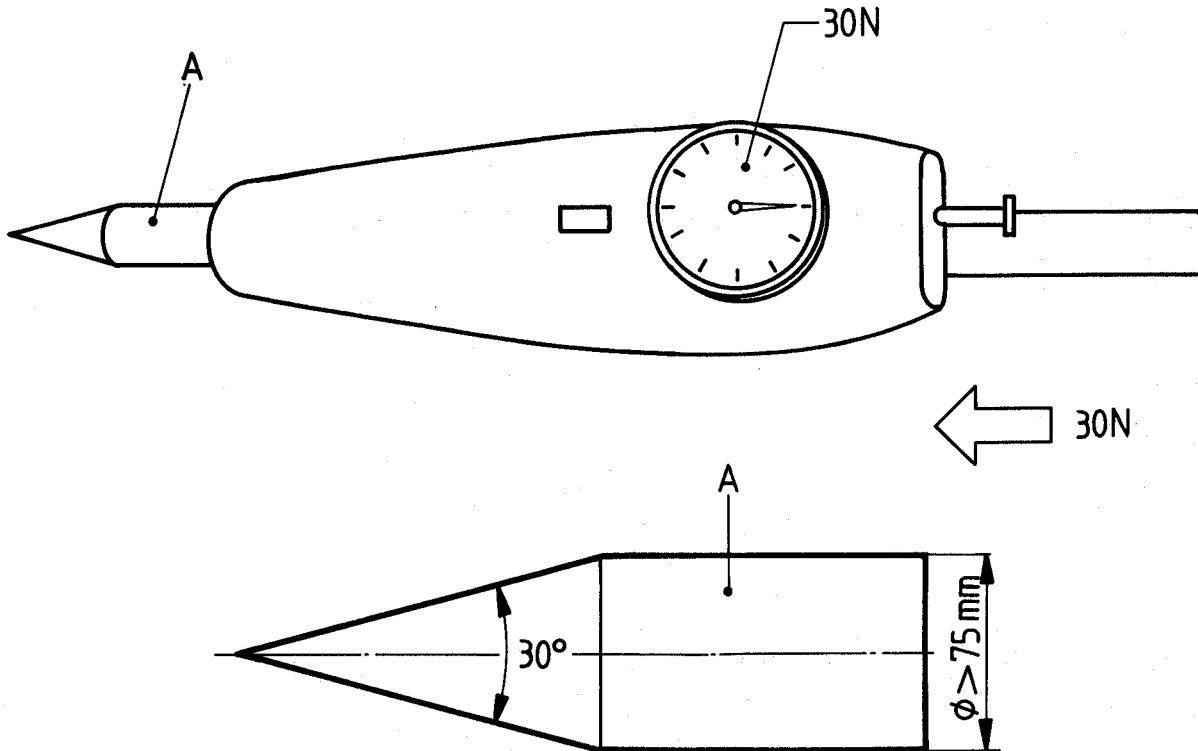

Figure 1 — Example of measuring cone
 iTeh STANDARD PREVIEW
 (standards.iteh.ai)

For the corrosion test (5.2), apparatus specified in the test methods referred to shall be used.

4.1 Slide gauge, cone made of plastics or other hard, smooth material mounted on a force-measuring device (see figure 1). The cone shall be marked with the diameters 7, 25, 60 and 75 mm.

4.2 Bottom impactor, mass of 10 kg of hardwood or equivalent material with dimensions according to figure 2.

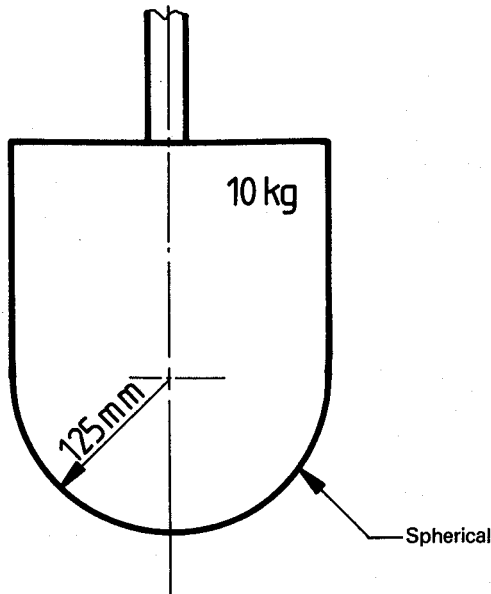

Figure 2 — Bottom impactor

4.3 Test mattress, soft polyether foam sheet with a thickness of 50 mm, a bulk density of $(30 \pm 2) \text{ kg/m}^3$ and an indentation hardness index of $(170 \pm 20) \text{ A } 40$ according to ISO 2439, at least 400 mm x 800 mm in area but not larger than the mattress base of the cot under test. The test mattress shall not have any cover.

4.4 Force-measuring device, e.g. spring balance.

4.5 Side impactor, cylindrical pendulum according to figure 4, basically made of steel, of total mass of 2 kg and with its centre of gravity situated 250 mm from the centre of its turning axes. The point of impact shall be 300 mm from its turning axes. The pendulum shall be surrounded by a 10 mm thick layer of rubber of hardness 76 to 78 IRHD according to ISO 48.

4.6 Test load, mass of 20 kg distributed over an area of approximately 150 mm x 150 mm.

4.7 Loading pad, rigid cylindrical object, 100 mm in diameter, having a smooth hard surface and rounded edges with radius of 12 mm.

4.8 Stops, to prevent the article from sliding but not tilting, no higher than 12 mm except in cases where the design of the item necessitates the use of higher stops, in which case the lowest that will prevent the item from moving shall be used.

4.9 Floor surface, horizontal and flat.

5. Test procedures

5.1 Assembly and inspection before test

The cot shall be assembled in accordance with the manufacturer's instructions. Prior to the test, inspect the cot visually for defects.

5.2 Corrosion resistance test

Expose metal parts that would be within the reach of the child to an atmosphere as specified in ISO 1521 for a period of 48 h. After this, determine the degree of corrosion on the basis of ISO 4628-3.

5.3 Inspection of workmanship

Inspect the specimen to determine whether exposed edges, screws, bolts, zips and other fittings are rounded or chamfered and free of burr and sharp edges.

5.4 Measuring of height of sides

Measure the internal height of the sides from the bed base at its lowest position, without mattress, or from parts of the sides on which the child could stand.

5.5 Measuring of clearance between side slats, mesh width and clearance between bed base and sides

Measure the distances between slats, meshes and between bed base and sides respectively when not under stress.

Press the slide gauge (4.1) with a force of 30 N between the side slats, between the meshes and between the bed base and the sides. Measure the clearance between adjacent elements under stress.

After removal of the force, measure the residual deflection of each side slat and the maximum inner width of the mesh.

5.6 Strength of bed base (impact test)

Place the test mattress flat on the bed base. Drop impactor (4.2) 1 000 times, at about 6 times per minute, through a distance of 150 mm above the bed base, onto the test mattress at each of the selected positions of impact. Permit the impactor to fall freely.

NOTE — A guide rail (to guide the impactor) is recommended.

Remove the test mattress and examine the specimen to determine if parts of the bed base are broken or if the bed base has loosened from its fastening.

The impact blow shall not hit the mattress on the same place when alternating between the impact points. The test mattress shall not be used for more than one cot.

The impacts shall be positioned as shown in figure 3 (points a to f), which are defined:

- a: any corner;
- b: any place where the bottom appears weakest, or — if no specific weak spot can be selected — in the corner diagonally opposite a;
- c: the centre of one side;
- d: the centre of one end;
- e: the centre of the bed base;
- f: if the bed base may have more than one height position, and if its support construction is not the same for the different positions, the base shall be tested additionally in its highest position, but then only at the two diagonal corners that have not been tested.

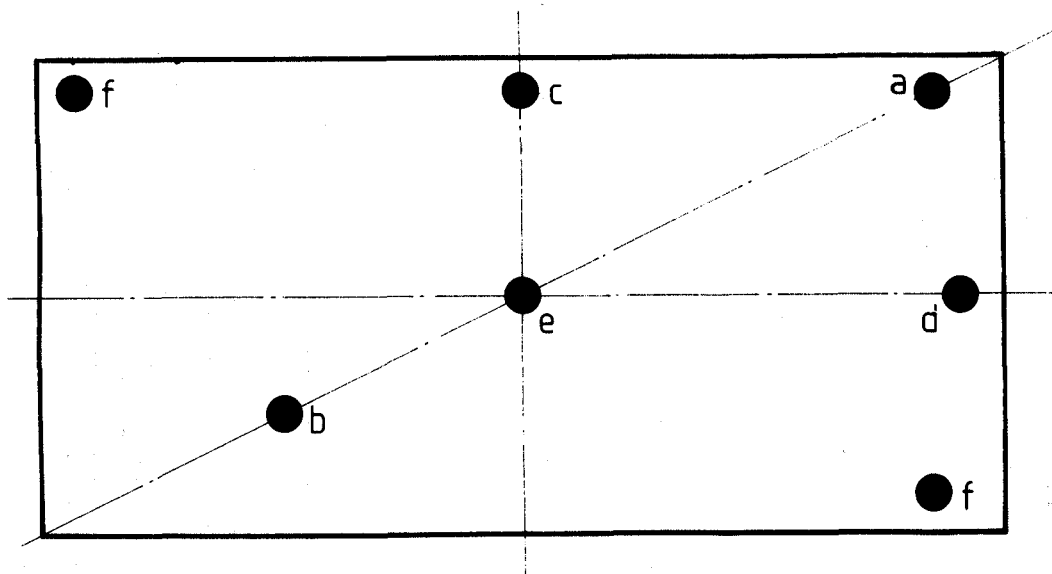

Figure 3 — Impact points

The horizontal distance between the impactor and the inner surface of the frame shall be not more than 50 mm at points a, c and f.

5.7 Strength of side slats (bending test)

Position the cot on the floor with all the legs secured against stops (4.8).

Use an appropriate force-measuring device (4.4).

Apply a force of 250 N in turn to one side slat positioned in the middle and one at the end of each side. The force shall act horizontally in the directions of the longitudinal and transverse axis of the cot. It shall be applied midway between the top and the bottom of the slat. The load duration shall be 30 s.

Record any break or deformation of slats or any other damage.

5.8 Strength of sides or side slats (impact test)

Position the cot on the floor with all the legs secured against stops (4.8).

Place the side impactor (4.5) in relation to the cot so that the impact acts on the side slat or side, from both the outside and inside directions, at a height of 200 mm below the top edge of the side (see figure 4).

One slat shall be hit from the outside, the next from the inside, and so forth.

When testing cots with solid sides, the impacts shall act on ten evenly distributed places on the long sides and four evenly distributed places on the end sides with the direction of impact alternating from inside to outside the cot.

Allow the impactor to swing freely from a horizontal position onto the side slat or side. Repeat ten times, then place the

impactor at the next slat or next point of impact. Continue the test until all slats or all previously determined impact points have been tested.

Position the impactor to hit the side frames as high and as close to the corner post as possible (see figure 5). Select the corner that appears weakest for this test. Allow the impactor to swing freely from an angle of 60° from the vertical. Carry out this procedure at each side member in each corner of the cot making five impacts from inside the cot and five impacts from outside the cot at each position.

Record any break or deformation of slats or any other damage.

5.9 Strength of frame and fastenings (fatigue test)

Position the cot on the floor with all the legs secured against stops (4.8).

Position the test load (4.6) at the centre of the bottom of the cot.

Apply forces of 100 N by means of the loading pad (4.7) and a device that can press the cot in four directions horizontally, with two of the forces in the longitudinal direction and two in the lateral direction (AB/CD) opposite each other [see figure 6 a)]. The forces shall act on each point in turn in the order A, B, C, D (which equals one cycle) and each time the force shall increase from 0 to 100 N and back to 0 in not less than 1 s.

The points for applying the forces (A, B, C, D) shall be located 50 mm in from the intersection point of the centrelines of the side members at the highest point at that position [see figure 6 b)].

After application of the forces for the required number of cycles, measure the movement of the frame, *a* (see figure 7), at each point with the force on and check the function of the fastenings.

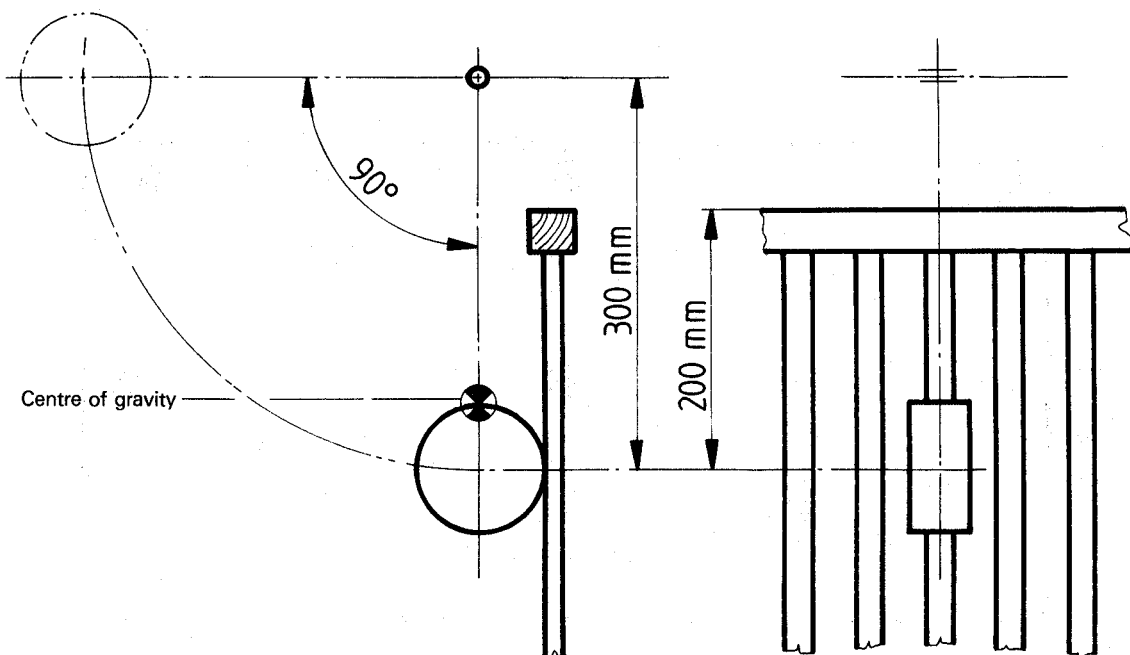

Figure 4 — Side impact pendulum

5.10 Stability test

Position the cot on the floor with the legs against stops (4.8). The tilting tendencies shall not be restrained.

In the case of cots with castors, place the castors in the most unfavourable position.

Fix the bed base at its highest position.

Apply a force as stated in ISO 7175-1 horizontally at the highest position of the outer frame and at the least stable position (see figure 8).

Record whether the opposite legs lift away from the floor.

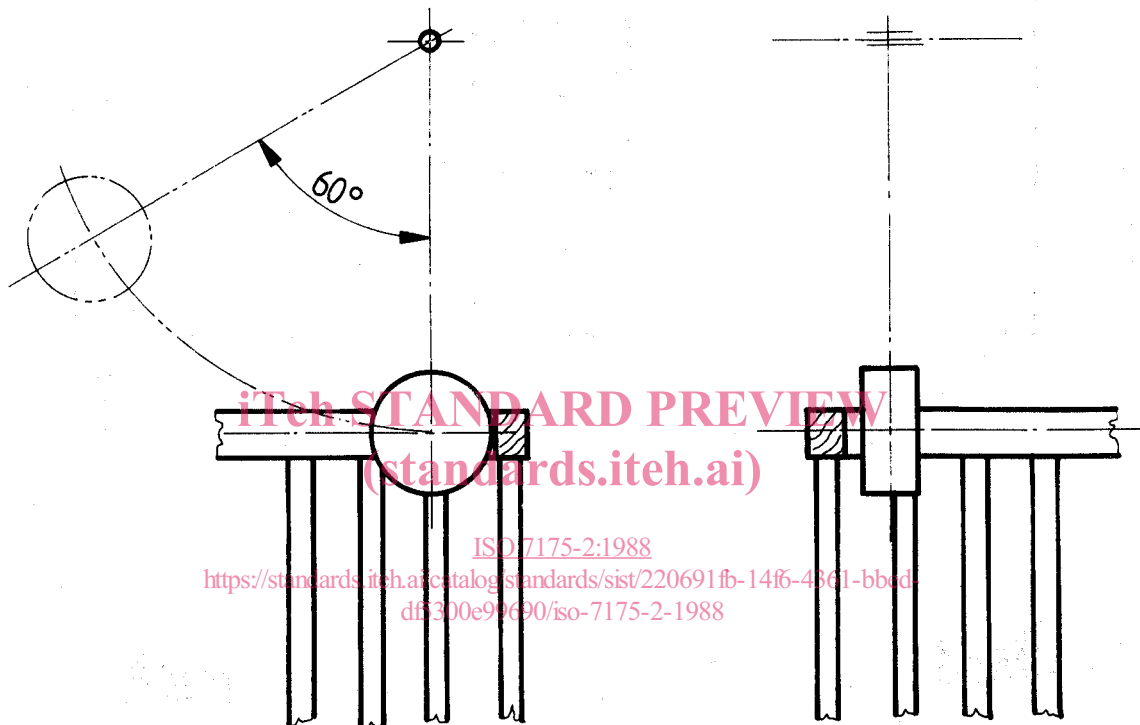

Figure 5 — Corner impact pendulum