International Standard



7188

INTERNATIONAL ORGANIZATION FOR STANDARDIZATION • МЕЖДУНАРОДНАЯ ОРГАНИЗАЦИЯ ПО СТАНДАРТИЗАЦИИ • ORGANISATION INTERNATIONALE DE NORMALISATION

Acoustics — Measurement of noise emitted by passenger cars under conditions representative of urban driving

Acoustique — Mesurage du bruit émis par les voitures particulières dans des conditions représentatives de la conduite en ville

First edition — 1985-11-15

iTeh STANDARD PREVIEW
(standards.iteh.ai)

[ISO 7188:1985](#)

<https://standards.iteh.ai/catalog/standards/sist/1dad7cb4-ccfe-4bc0-849a-c35e8b78ec25/iso-7188-1985>

UDC 534.6 : 629.113

Ref. No. ISO 7188-1985 (E)

Descriptors : acoustics, private cars, tests, acoustic tests, determination, noise (sound), sound pressure.

Price based on 5 pages

Foreword

ISO (the International Organization for Standardization) is a worldwide federation of national standards bodies (ISO member bodies). The work of preparing International Standards is normally carried out through ISO technical committees. Each member body interested in a subject for which a technical committee has been established has the right to be represented on that committee. International organizations, governmental and non-governmental, in liaison with ISO, also take part in the work.

Draft International Standards adopted by the technical committees are circulated to the member bodies for approval before their acceptance as International Standards by the ISO Council. They are approved in accordance with ISO procedures requiring at least 75 % approval by the member bodies voting.

International Standard ISO 7188 was prepared by Technical Committee ISO/TC 43, *Acoustics*.

Users should note that all International Standards undergo revision from time to time and that any reference made herein to any other International Standard implies its latest edition, unless otherwise stated.

iTeh STANDARD PREVIEW
(standards.iteh.ai)

ISO 7188:1985
<http://standards.iteh.ai/catalog/standards/sist/1dad7cb4-ccfe-4bc0-849a-c35e8b78ec25/iso-7188-1985>

Acoustics — Measurement of noise emitted by passenger cars under conditions representative of urban driving

iTeh STANDARD PREVIEW
(standards.iteh.ai)

1 Scope and field of application

This International Standard specifies a method for measuring the noise emitted by passenger cars (as defined in ISO 3833) in motion.

The method is based on statistical studies of the use of cars in urban driving. It is designed to meet the requirement of simplicity as far as that is consistent with reproducibility of results and realism in representing the operating conditions of the vehicle.

The specifications are intended to reproduce the noise level which is exceeded during only 5 % of the total driving time in urban traffic flow of irregular character which requires the use of intermediate gears. The noise level obtained is in good correlation with the equivalent continuous A-weighted sound pressure level (see ISO 1996/1), $L_{Aeq,T}$, emitted by the vehicle during urban driving.

Information is also given, in footnotes, for the assessment of the noise level which is exceeded during only 1 % of the total driving time.

NOTE — The test method calls for an acoustical environment which can only be obtained in an extensive open space. Such conditions can usually be provided for :

- type approval measurements of vehicles,
- measurements at the manufacturing stage, and
- measurements at official testing stations.

It should be noted that spot checking of vehicles chosen at random can rarely be made in an ideal acoustical environment. If measurements

have to be carried out on the road in an acoustical environment which does not fulfil the requirements stated in this International Standard, it should be recognized that the results obtained may deviate appreciably from those obtained under the specified conditions.

2 References

- ISO 1176, *Road vehicles — Weights — Vocabulary.*
- ISO 1585, *Road vehicles — Engines test code — Net power.*
- ISO 1996/1, *Acoustics — Description and measurement of environmental noise — Part 1 : Basic quantities and procedures.*
- ISO 3833, *Road vehicles — Types — Terms and definitions.*
- IEC Publication 651, *Sound level meters.*

3 Definitions

For the purpose of this International Standard, the following definitions apply.

3.1 automatic downshift : A gear change to a lower gear (higher numerical ratio) which occurs outside the control of the driver.

3.2 external downshift : A gear change to a lower gear (higher numerical ratio) which can be initiated at the will of the driver. An external downshift may be initiated, for example, by a change of pressure on the throttle pedal, or by a change in the position of the throttle pedal, thereby activating an external switch which effects the downshift.

4 General requirements

4.1 Principle

This International Standard is based on tests with vehicles in motion. Measurements are made in two driving modes, namely

- a) an acceleration test at full throttle from a specified road speed;
- b) a constant speed test at the same road speed.

In order to obtain a noise level characteristic of urban driving the results of the two tests are combined in a specified manner.

NOTE — The conditions used for these two tests bracket the urban driving conditions and it is to be understood that neither of them taken alone would be representative.

4.2 Interpretation of results

The results obtained by this method give an objective measure of the noise emitted under the specified conditions of test. However, it is necessary to consider the fact that the subjective appraisal of the annoyance of different classes of vehicle is not simply related to the indications of a sound level meter.

5 Instrumentation

5.1 Instrumentation for acoustical measurements

The sound level meter (or the equivalent measuring system) shall at least meet the requirements of a type 1 instrument in accordance with IEC Publication 651.

The measurements shall be made using the frequency weighting "A" and the time weighting characteristic "F".

The calibration of the sound level meter shall be checked and adjusted according to the manufacturer's instructions or with a standard sound source (for example, a pistonphone) at the beginning of the measurements and rechecked and recorded at the end of them. Any deviations shall be recorded in the test report. It is recommended that, if these deviations are greater than 1 dB, the test be considered invalid.

If a windscreen is used, it shall be of a type specified by the manufacturer as suitable for the particular microphone. It shall be ascertained from the manufacturer that the use of the windscreen does not affect the measured value of the A-weighted sound pressure level by more than 0,5 dB.

5.2 Instrumentation for speed measurements

The rotational speed of the engine and the road speed of the vehicle during the approach shall be measured to an accuracy of 3 % or better.

6 Acoustical environment, meteorological conditions and background noise

6.1 Test site

The test site shall be substantially level; the surface of the test track shall be dry and its texture such that it does not cause excessive tyre noise.¹⁾

The test site shall be such that when a small omnidirectional noise source is placed in its surface at point O in figure 1, deviations from hemispherical divergence shall not exceed ± 1 dB.

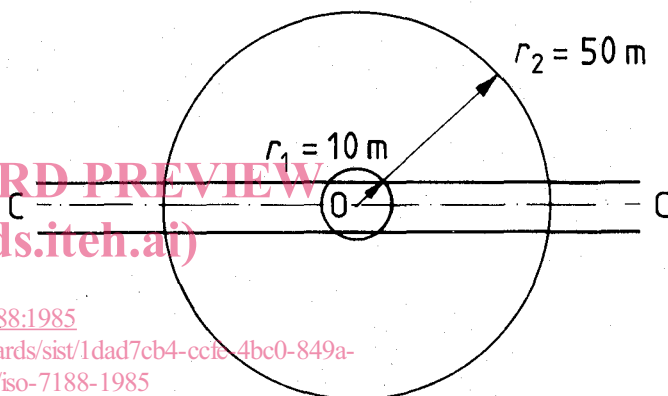

Figure 1 — Test site

This condition is deemed to be satisfied if the following requirements are met :

- a) within a radius of 50 m around the centre of the track, the space shall be free of large reflecting objects, such as fences, rocks, bridges or buildings;
- b) the test track and the surface of the site up to 10 m from the centre O of the track shall consist of concrete, asphalt or similar hard material and shall be free from absorbing materials, such as powdery snow, long grass or ashes;
- c) in the vicinity of the microphone, there shall be no obstacle that could influence the acoustical field and no per-

1) A precise specification for the texture and composition of the test track, to define a surface which will produce minimum tyre rolling noise and high acoustic reflectivity, will be given as soon as standardization of these road surface properties has been achieved.

son shall come between the microphone and the noise source. The meter observer shall be positioned so as not to influence the meter reading.

6.2 Meteorological conditions

The measurements shall not be made in adverse weather conditions.

Measurements shall not be carried out if the wind is gusty. It is recommended that measurements should not be carried out at wind speeds exceeding 5 m/s at microphone height.

6.3 Background noise

The background noise (including any wind noise) shall be at least 10 dB below that produced by the vehicle under test.

7 Test procedure

7.1 Microphone positions

The distance from the microphone positions to the reference line CC (see figure 2) on the test track shall be $7,5 \pm 0,1$ m.

The microphone shall be located $1,2 \pm 0,05$ m above ground level. Unless otherwise indicated by the manufacturer of the sound level meter, its reference axis for free-field conditions (see IEC Publication 651) shall be horizontal and directed perpendicularly towards the path of the vehicle (line CC).

Dimensions in metres

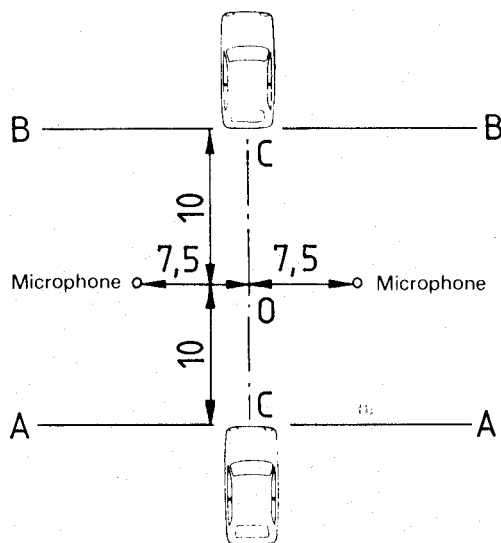

Figure 2 — Microphone positions for measurements

7.2 Number of measurements

At least two measurements shall be made on each side of the vehicle.

7.3 Readings to be taken

The maximum sound pressure level indicated during each passage of the vehicle between the two lines AA and BB (see figure 2) shall be noted. If a sound peak obviously out of character with the general sound level is observed, the measurement shall be discarded.

The results shall be considered valid if the difference between two consecutive measurements made on the side of the vehicle which gives the higher sound pressure level does not exceed 2 dB.

The highest value given by these measurements in each type of test shall constitute the result.

7.4 Conditions of the vehicle

Measurements shall be made on vehicles unladen except for the driver and, except in the case of non-separable vehicles, without trailer or semi-trailer.

The tyres of the vehicle shall be of the type normally fitted by the manufacturer to the vehicle and shall be inflated to the pressure(s) recommended by the manufacturer for the vehicle in its unladen condition.

Before the measurements are started, the power train shall be set to the manufacturer's specification and brought to its normal operating temperatures. It shall be supplied with fuel, sparking plugs, carburettor(s), etc., as recommended by the manufacturer.

7.5 Operating conditions

7.5.1 General conditions

The vehicle shall approach the line AA with the path of its centreline following as closely as possible the line CC as specified in 7.5.2.1 to 7.5.2.3 as appropriate.

During the acceleration test, when the front of the vehicle reaches the line AA, the throttle shall, as rapidly as possible, be opened as fully as possible to ensure acceleration without external downshift occurring (for example, by kick-down, if any) and shall be held in this position until the rear of the vehicle reaches line BB; the throttle shall then be closed as rapidly as possible.

During the constant speed test, the throttle shall be held fixed in such a position as will maintain between AA and BB the constant speed specified in 7.5.2.

If the vehicle is fitted with more than two wheel drive, it shall be tested in the drive which is intended for normal road use.

If the vehicle is fitted with an auxiliary manual transmission or a multi-gear axle, the position used for normal urban driving shall be used.

In all cases, the gear ratios for slow movements, parking or braking shall be excluded.

7.5.2 Special conditions

7.5.2.1 Manual transmission vehicle

For both the constant speed test and the acceleration test, the vehicle shall approach the line AA in second gear at a uniform vehicle speed calculated¹⁾ from the equation

$$v_{AA} = \frac{33 + 0,55 v_s}{2}$$

where

v_{AA} is the vehicle entry speed, in kilometres per hour;

v_s is the vehicle speed, in kilometres per hour, in second gear at engine speed s , s being the speed at which the engine produces its net maximum power or the maximum rotational speed allowed by the governor (if any) at full-load conditions of the engine.

7.5.2.2 Automatic transmission vehicle with discrete or continuous gear ratios

For both the constant speed test and the acceleration test, the vehicle shall approach the line AA at a uniform vehicle speed (not exceeding 50 km/h) calculated²⁾ from the equation

$$v_{AA} = \frac{50 + 0,20 v_m}{2}$$

where

v_{AA} is the vehicle entry speed, in kilometres per hour;

v_m is the maximum speed, in kilometres per hour, of the vehicle as specified by the manufacturer.

These tests shall be performed with the selector in the position corresponding to the condition for normal urban driving.

External downshift (for example, by kick-down) as well as automatic downshifting to the first ratio for gearboxes having more than two discrete ratios shall be excluded.

7.5.2.3 Vehicles without gearbox

For both the acceleration and constant speed tests, the vehicle shall approach the line AA at uniform speed calculated³⁾ from the equation

$$v_{AA} = \frac{33 + 0,25 v_m}{2}$$

where v_m is the maximum speed, in kilometres per hour, of the vehicle as specified by the manufacturer.

8 Calculation of the characteristic sound pressure level of the vehicle

The characteristic sound pressure level L_R , in decibels, of a vehicle shall be calculated from the equation

$$L_R = L_{acc} - K (L_{acc} - L_c)$$

where

L_{acc} is the maximum A-weighted sound pressure level, in decibels, measured during the acceleration test;

L_c is the maximum A-weighted sound pressure level, in decibels, measured during the constant speed test;

K is a weighting factor which depends on the power-to-mass ratio and transmission system; it is given⁴⁾ by

$$K = 0,8, \text{ or}$$

$$K = 0,3 + 5 P/m \text{ for vehicles with manual gearboxes or without gearboxes, or}$$

$$K = 0,2 + 5 P/m \text{ for vehicles with automatic transmission,}$$

1) For the assessment of the noise level which is exceeded during only 1 % of the total driving time, use the equation

$$v_{AA} = \frac{33 + 0,8 v_s}{2}$$

2) For the assessment of the noise level which is exceeded during only 1 % of the total driving time, use the equation

$$v_{AA} = \frac{50 + 0,35 v_m}{2} \text{ (without exceeding 60 km/h)}$$

3) For the assessment of the noise level which is exceeded during only 1 % of the total driving time, use the equation

$$v_{AA} = \frac{33 + 0,35 v_m}{2}$$

4) For the assessment of the noise level which is exceeded during only 1 % of the total driving time, use

$$K = 0,55, \text{ or}$$

$$K = 0,15 + 4 P/m \text{ for vehicles with manual gearboxes or without gearboxes; or}$$

$$K = 0,10 + 4 P/m \text{ for vehicles with automatic transmission; whichever is the lower.}$$

whichever is the lower, where

P is the net maximum power of the engine, in kilowatts, as determined by the method specified in ISO 1585;

m is the complete vehicle kerb mass, in kilograms, as defined in ISO 1176 and specified by the manufacturer.

9 Test report

The test report shall include the following information :

- a) reference to this International Standard;
- b) details of the test site, the testing ground conditions and meteorological conditions;
- c) the measurement equipment (including windscreen, if used);
- d) the A-weighted sound pressure level of the background noise;
- e) the identification of the vehicle, its engine, its transmission system and its tyres including their inflation pressure(s);
- f) the road speed at the beginning of the test runs, the gear ratios used and the special arrangements adopted, if any;
- g) the auxiliary equipment, where appropriate, and its operating conditions;
- h) deviations (if any) observed in the calibration of the instruments during the tests;
- j) the number of measurements and the A-weighted sound pressure levels recorded, in decibels;
- k) the calculated characteristic sound pressure level (L_R), truncated after one decimal place.

iTeh STANDARD PREVIEW
(standards.iteh.ai)

ISO 7188:1985

<https://standards.iteh.ai/catalog/standards/sist/1dad7cb4-ccfe-4bc0-849a-c35e8b78ec25/iso-7188-1985>