International Standard



7193

INTERNATIONAL ORGANIZATION FOR STANDARDIZATION • МЕЖДУНАРОДНАЯ ОРГАНИЗАЦИЯ ПО СТАНДАРТИЗАЦИИ • ORGANISATION INTERNATIONALE DE NORMALISATION

Wheelchairs — Maximum overall dimensions

Fauteuils roulants — Dimensions maximales hors tout

First edition — 1985-12-01

iTeh STANDARD PREVIEW
(standards.iteh.ai)

[ISO 7193:1985](https://standards.iteh.ai/catalog/standards/sist/4b694ca7-cf26-46f4-b646-169a5ee5ebd3/iso-7193-1985)

<https://standards.iteh.ai/catalog/standards/sist/4b694ca7-cf26-46f4-b646-169a5ee5ebd3/iso-7193-1985>

UDC 615.478.32 : 629.012

Ref. No. ISO 7193-1985 (E)

Descriptors : wheel chairs, dimensions.

Foreword

ISO (the International Organization for Standardization) is a worldwide federation of national standards bodies (ISO member bodies). The work of preparing International Standards is normally carried out through ISO technical committees. Each member body interested in a subject for which a technical committee has been established has the right to be represented on that committee. International organizations, governmental and non-governmental, in liaison with ISO, also take part in the work.

Draft International Standards adopted by the technical committees are circulated to the member bodies for approval before their acceptance as International Standards by the ISO Council. They are approved in accordance with ISO procedures requiring at least 75 % approval by the member bodies voting.

International Standard ISO 7193 was prepared by Technical Committee ISO/TC 173, *Technical systems and aids for disabled or handicapped persons*.

Users should note that all International Standards undergo revision from time to time and that any reference made herein to any other International Standard implies its latest edition, unless otherwise stated.

Wheelchairs — Maximum overall dimensions

0 Introduction

The purpose of this International Standard is to provide the maximum overall dimensions of manual and electric wheelchairs to be taken into account by architects, engineers, manufacturers and public authorities with regard to the accessibility of, for example, motor vehicles, buses, ships, aircraft, lifts, kitchen equipment and to general manoeuvrability. Furthermore, the specified limits of overall dimensions may give guidance to the wheelchair manufacturer for new developments.

The specified dimensions are based on the unoccupied wheelchair (see also notes 3 and 4 in 4.2).

Guidance on functional needs of handicapped people in buildings is given in *Needs of the handicapped in buildings — Design guidelines*, Geneva, ISO, March 1982.

1 Scope and field of application

This International Standard lays down the maximum limits of overall dimensions on wheelchairs primarily intended for indoor use. It applies to manual as well as electric wheelchairs in their operational condition, and covers wheelchairs usable by 85 % of disabled people.

2 References

ISO 6440, *Wheelchairs — Nomenclature, terms and definitions*.

ISO 7176/5, *Wheelchairs — Part 5: Determination of overall dimensions, mass and turning space*.

3 Definitions

For the purposes of this International Standard, the definitions given in ISO 6440 and the following definitions apply.

3.1 overall length, l : The horizontal distance between the forwardmost and rearmost part of the wheelchair.

3.2 overall width, b : The horizontal distance between the outermost side parts of the wheelchair when it is fully extended and the seat fully stretched out.

3.3 overall height, h : The vertical distance from the floor to the uppermost point on the wheelchair.

4 Overall dimensions

4.1 The specified overall dimensions are measured in accordance with ISO 7176/5.

4.2 The wheelchair shall be deemed to be in conformity with this International Standard if the dimensions do not exceed the following maximum values (see the figure) :

- overall length, l : 1 200 mm
- overall width, b : 700 mm
- overall height, h : 1 090 mm

NOTES

1 The length of wheelchairs generally ranges between 1 100 and 1 200 mm.

2 The width of wheelchairs generally ranges between 600 and 700 mm.

3 The user's feet add approximately 50 mm to the overall length.

4 To propel a wheelchair manually by operating the rims of the main wheels, a clearance of not less than 50 mm and preferably 100 mm is needed on both sides.

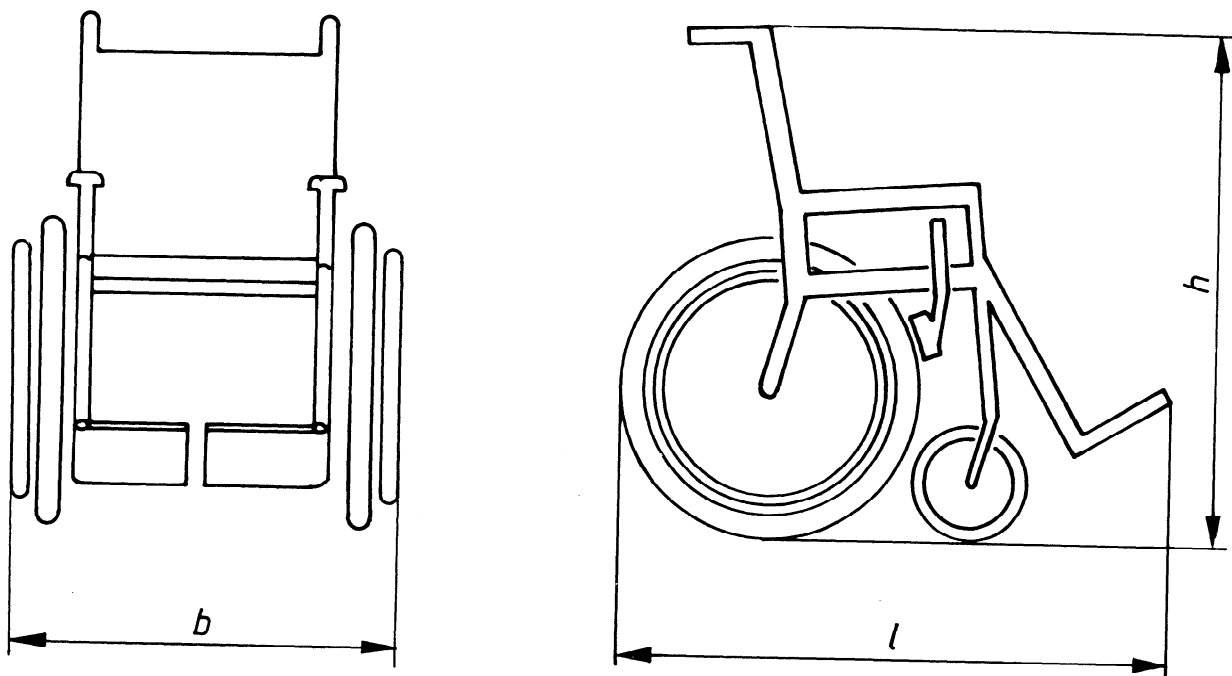

Figure
iTeh STANDARD PREVIEW
(standards.iteh.ai)

ISO 7193:1985

<https://standards.iteh.ai/catalog/standards/sist/4b694ca7-cf26-46f4-b646-169a5ee5ebd3/iso-7193-1985>