

INTERNATIONAL STANDARD

ISO
7206-3

First edition
1988-06-15



INTERNATIONAL ORGANIZATION FOR STANDARDIZATION
ORGANISATION INTERNATIONALE DE NORMALISATION
МЕЖДУНАРОДНАЯ ОРГАНИЗАЦИЯ ПО СТАНДАРТИЗАЦИИ

Implants for surgery — Partial and total hip joint prostheses —

Part 3 :

Determination of endurance properties of stemmed femoral components without application of torsion

IT IS STANDARD PREVIEW
(standards.iteh.ai)

Implants chirurgicaux — Prothèses partielles et totales de l'articulation de la hanche —

Partie 3 : Détermination des propriétés d'endurance des tiges fémorales sans application de torsion

ISO 7206-3:1988
<https://standards.iteh.ai/catalog/standards/sist/3651be78-3869-42f1-925c-578cc4c7089/iso-7206-3-1988>

Contents

	Page
Foreword	iii
Introduction	iv
1 Scope	1
2 Normative references	1
3 Definitions	1
4 Principle of the test method	1
5 Reagents and materials	1
6 Apparatus	2
7 Procedure	4
8 Test report	4
9 Disposal of test specimens	4
Annexes	
A Guidance on composition of high-alumina cement embedding medium	6
B Example of a method for setting up a specimen for testing	7

iTeh STANDARD PREVIEW
(standards.iteh.ai)

[ISO 7206-3:1988](https://standards.iteh.ai/catalog/standards/sist/3651be78-3869-42f1-925c-578ee4fc7689/iso-7206-3-1988)

<https://standards.iteh.ai/catalog/standards/sist/3651be78-3869-42f1-925c-578ee4fc7689/iso-7206-3-1988>

Foreword

ISO (the International Organization for Standardization) is a worldwide federation of national standards bodies (ISO member bodies). The work of preparing International Standards is normally carried out through ISO technical committees. Each member body interested in a subject for which a technical committee has been established has the right to be represented on that committee. International organizations, governmental and non-governmental, in liaison with ISO, also take part in the work. ISO collaborates closely with the International Electrotechnical Commission (IEC) on all matters of electrotechnical standardization.

Draft International Standards adopted by the technical committees are circulated to the member bodies for approval before their acceptance as International Standards by the ISO Council. They are approved in accordance with ISO procedures requiring at least 75 % approval by the member bodies voting.

International Standard ISO 7206-3 was prepared by Technical Committee ISO/TC 150, *Implants for surgery*.

<https://standards.iteh.ai/catalog/standards/sist/3651be78-3869-42ff-925c-8440f6a88772/iso-7206-3-1988>

ISO 7206 consists of the following parts, under the general title *Implants for surgery – Partial and total hip joint prostheses* :

- *Part 1 : Classification, designation of dimensions and requirements.*
- *Part 2 : Bearing surfaces made of metallic and plastics materials.*
- *Part 3 : Determination of endurance properties of stemmed femoral components without application of torsion.*
- *Part 4 : Determination of endurance properties of stemmed femoral components with application of torsion.*

Annexes A and B do not form an integral part of the standard.

Introduction

The following principles have been adopted in the development of the test method for determining the endurance properties of stemmed femoral components of hip joint prostheses described in this part of ISO 7206 :

a) the anatomical axis of the femur has been assumed to be at an angle of 10° to the load line, when viewed perpendicular to the plane that includes the stem and neck;

b) because of the complexity of the dynamic loading pattern in the patient, the diverse geometry of hip joint prostheses and the operative technique at implantation, certain factors (notably, the anteversion angle introduced at implantation, moment arm, maximum bending moment, calcar support and swing phase loading) are not referred to in this part of ISO 7206;

c) the test conditions are based on the assumption that the stem of the prosthesis has become unsupported through breakdown of the proximal cement or bone, and therefore no account can be taken of any features of a femoral component that are intended to prevent cement breakdown or to aid implantation of the component in the optimum position.

Experience in clinical practice has shown that failure of femoral components is most likely to occur at a distance of between 25 mm and 90 mm below the centre of the head of the component. It is thought that this observation reflects a combination of factors such as placement of the prosthesis, bone resorption, stem loosening and bone cement breakdown.

For reproducibility of location of the prosthesis in the test rig, the embedding depth ($80 \text{ mm} \pm 2 \text{ mm}$) has been related to point C of the component, as designated in ISO 7206-1, i.e. the centre of the head of the prosthesis.

This part of ISO 7206 describes a test method for obtaining the endurance properties of the prosthesis under a constant loading range. It is generally felt that the important factors are the application of cyclic stress, the value of the mean stress, the environment and the orientation of the femoral component in relation to the applied load. It is believed that the waveform has very little effect on specimen life. A loading system has been selected comprising a mean load together with a sinusoidal dynamic load. The loading frequency has been selected to give an acceptably low cyclic rate and a reasonable duration of testing [5×10^6 cycles requires 139 h (approximately 6 days) at 10 Hz or 278 h (approximately 11,5 days) at 5 Hz].

This part of ISO 7206 does not specify the loading range to be applied to the test prosthesis nor the number of load cycles.

It is imperative that, after testing, the prosthesis should not be used for clinical purposes.

Implants for surgery — Partial and total hip joint prostheses —

Part 3 : Determination of endurance properties of stemmed femoral components without application of torsion

1 Scope

This part of ISO 7206 describes a test method for determining the endurance properties, under specified laboratory conditions, of stemmed femoral components of total hip joint prostheses and stemmed femoral components used alone in partial hip joint replacement, without the application of torsion. It also defines the conditions of testing so that the important parameters that affect the components are taken into account, and describes how the specimen is set up for testing.

This test method has been developed for prostheses that have a plane of symmetry, and may not be suitable for other designs of prosthesis, e.g. those having preformed anteversion or double curvature of the stem.

This part of ISO 7206 does not cover methods of examining and reporting of the test specimen; these should be agreed between the test laboratory and the party submitting the specimen for test.

2 Normative references

The following standards contain provisions which, through reference in this text, constitute provisions of this part of ISO 7206. At the time of publication, the editions indicated were valid. All standards are subject to revision, and parties to agreements based on this part of ISO 7206 are encouraged to investigate the possibility of applying the most recent editions of the standards listed below. Members of IEC and ISO maintain registers of currently valid International Standards.

ISO 3696 : 1987, *Water for analytical laboratory use — Specifications and test methods*.

ISO 4965 : 1979, *Axial load fatigue testing machines — Dynamic force calibration — Strain gauge technique*.

ISO 5833 : 1979, *Implants for surgery — Acrylic resin cements — Part 1 : Orthopaedic applications*.

ISO 7206-1 : 1985, *Implants for surgery — Partial and total hip joint replacements — Part 1 : Classification, designation of dimensions and requirements*.

ISO 7500-1 : 1986, *Metallic materials — Verification of static uniaxial testing machines — Part 1 : Tensile testing machines*.

3 Definitions

For the purposes of this part of ISO 7206, the definitions given in ISO 7206-1 apply.

4 Principle of the test method

Embedding of the lower portion of the test specimen in a solid medium. Partial immersion of the protruding part of the test specimen in a fluid test medium. Application of a cyclic load to the head of the test specimen until the specimen exhibits failure or until the chosen number of cycles has been attained. Subsequent examination of the specimen for defects caused by the loading regime.

5 Reagents and materials

5.1 Fluid test medium

Solution of analytical grade sodium chloride
[$\rho(\text{NaCl}) = 9 \text{ g/l}$], continuously aerated, in distilled or deionized water of grade 3 as specified in ISO 3696.

5.2 Embedding medium

A casting medium, which should

- not be affected by the fluid test medium (5.1);
- not crack or break under the load applied during testing;
- not exhibit excessive deformation or creep;
- be reproducible in strength and other characteristics.

Three media that appear satisfactory are acrylic bone cement (see ISO 5833-1), epoxy casting resin and high-alumina cement (see annex A which contains guidance on a satisfactory composition of high-alumina cement).

6 Apparatus

6.1 Testing machine, having the following characteristics :

- a) error in applied load : not greater than $\pm 1\%$ at maximum load (see ISO 7500-1 and ISO 4965);
- b) dynamic loading waveform : sinusoidal;
- c) instrumentation to monitor the values of the maximum

and minimum loads and the deflection of the head of the test specimen to an accuracy of $\pm 2\%$ and to record the number of cycles or the elapsed time of operation.

6.2 Specimen holders, of a corrosion-resistant material and having a construction and dimensions to suit the testing machine and test specimens. An example of a suitable holder is shown in figure 1.

Dimensions in millimetres

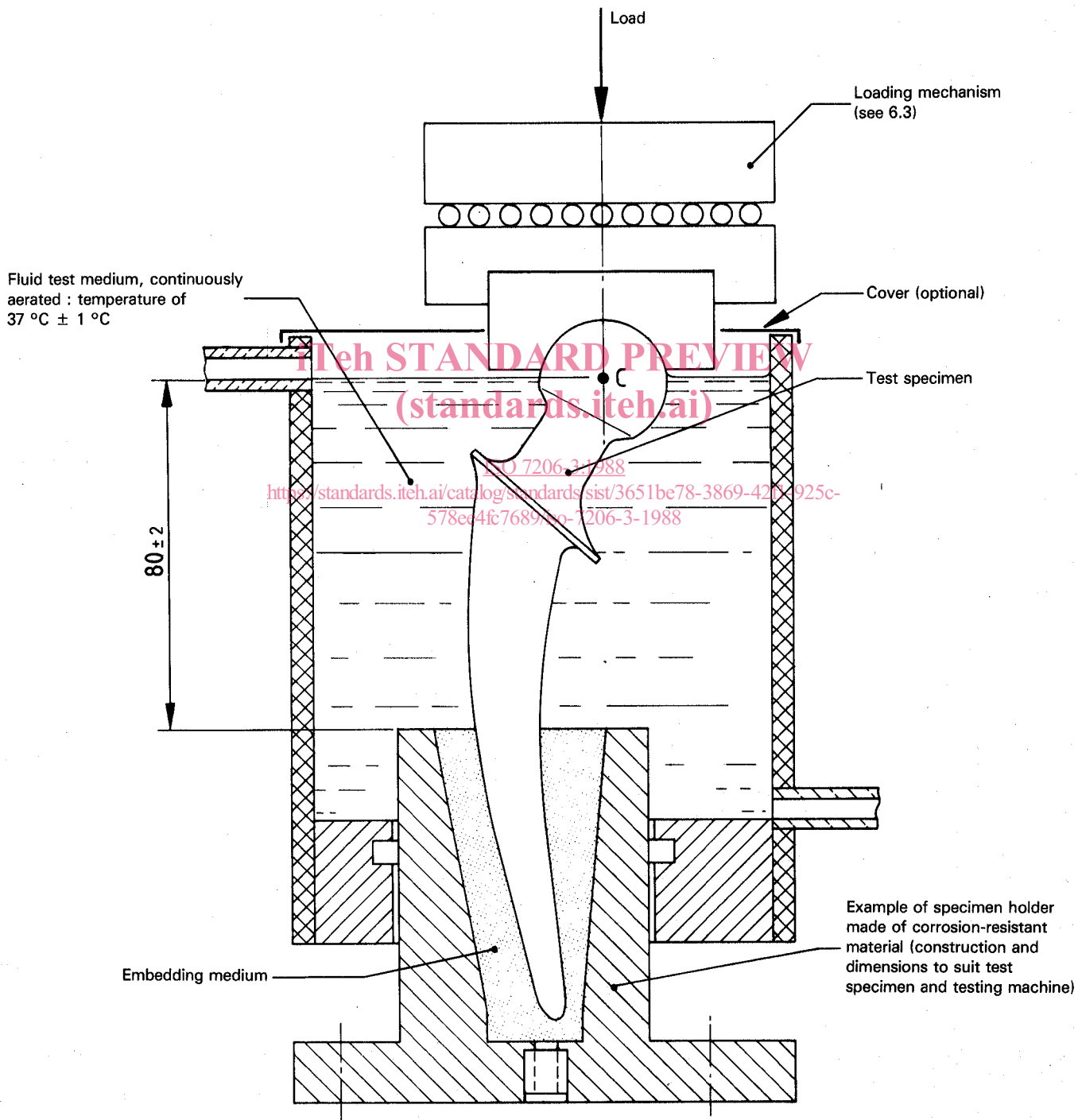

NOTE — Point C is designated in ISO 7206-1.

Figure 1 — General arrangement of specimen for testing

6.3 Means of loading the test specimen which maintains loading through the centre of the head of the specimen, parallel to the axis of the testing machine, and which incorporates a low-friction mechanism that minimizes loads not parallel to the axis of the testing machine.

NOTE — Attention is drawn to the importance of lubricating the loading mechanism correctly.

6.4 Means of continuously aerating the fluid test medium, e.g. a small air pump of the type used for aquaria.

6.5 Means of maintaining the temperature of the fluid test medium at $37\text{ }^{\circ}\text{C} \pm 1\text{ }^{\circ}\text{C}$.

6.6 Means of maintaining constant composition of the fluid test medium, e.g. by continual replenishment from a reservoir.

6.7 Device to grip the test specimen by the head or neck, which retains the specimen in any desired orientation. An example of a suitable device to grip the head of the specimen is shown in figure 2.

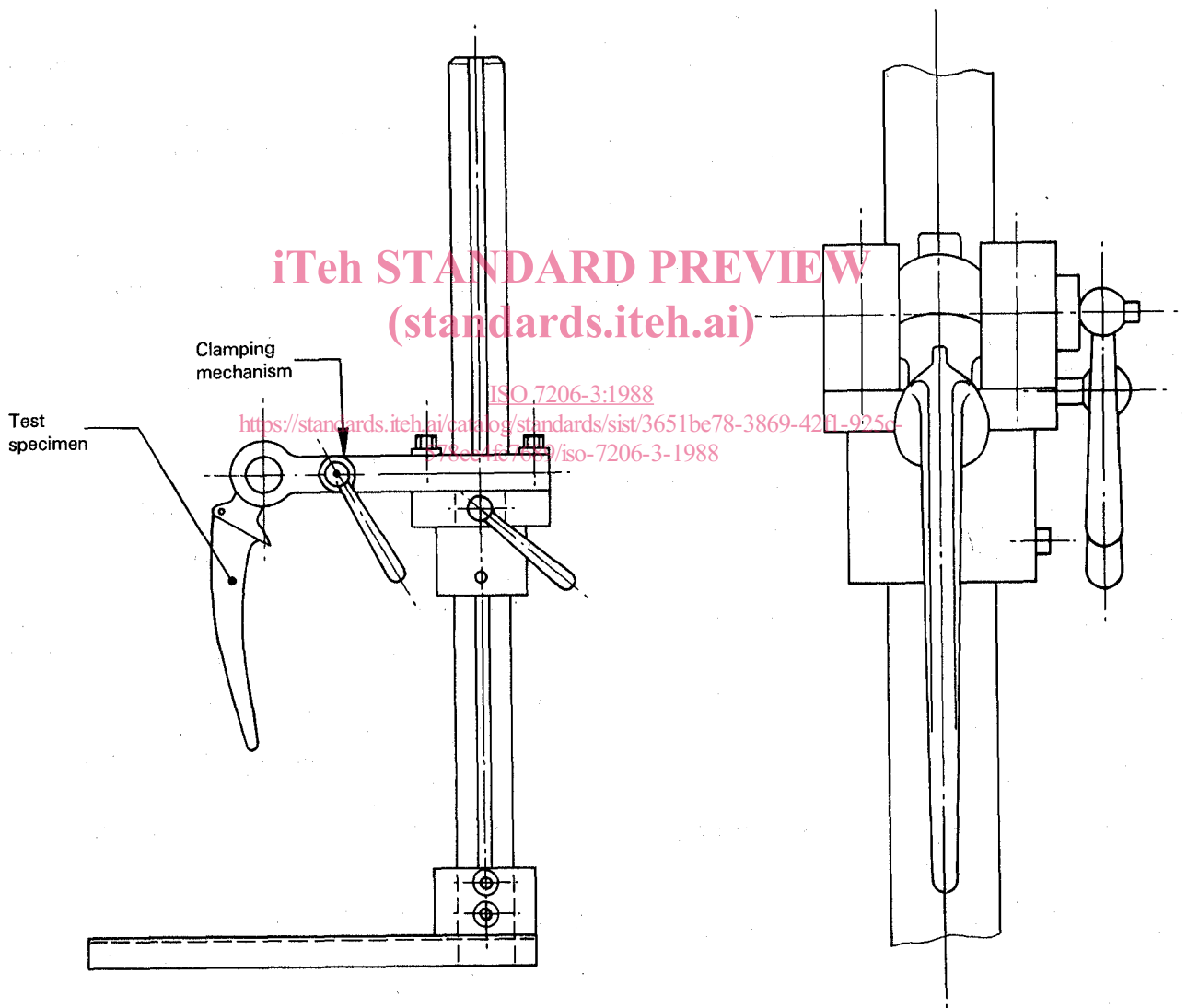

Figure 2 — Example of a device for gripping the head of the test specimen during setting-up (see 6.7)

7 Procedure

7.1 Hold the head or neck of the test specimen by means of the gripping device (6.7) and position the specimen so that axis KL of the stem, as designated in figure 3, is inclined at an angle of 10° to the vertical. An example of a technique that may be used for setting the specimen in the correct orientation is given in annex B.

NOTE — It is essential that the neck of the prosthesis is not marked or damaged during this process because damage can affect the endurance properties. Damage to the head of the prosthesis should also be avoided as this can increase the friction between the head and the loading system during testing.

7.2 Embed the specimen in the embedding medium (5.2) in the holder (6.2) so that the upper surface of the medium is at a distance of 80 mm ± 2 mm vertically below the centre of the head of the prosthesis (point C as defined in ISO 7206-1). Take care not to mark or otherwise damage the stem.

7.3 Support the test specimen in position until the embedding medium has hardened sufficiently to support the specimen unaided. Do not start testing until the embedding medium has hardened fully.

7.4 Mount the holder and embedded specimen in the testing machine (6.1) so that the load line of the testing machine intersects point C of the specimen, as defined in ISO 7206-1. Clamp the holder firmly in position and ensure that the correct orientation of the specimen is maintained. Measure and record the head offset length, as designated in figure 3.

7.5 Partially immerse the specimen in the fluid test medium (5.1) so that the surface of the liquid is approximately level with the centre of the head of the test specimen. Maintain the aeration, temperature and composition of the fluid test medium by the appropriate means (see 6.4 to 6.6).

7.6 Start the testing machine and adjust it so that the desired load range is applied to the test specimen through the loading mechanism (6.3).

NOTE — The minimum load necessary for satisfactory operation of the testing machine has been found to be a force between 200 N and 300 N.

7.7 Operate the testing machine at a chosen frequency of between 1 Hz and 10 Hz.

NOTE — A frequency of 1 Hz is recommended for testing non-metallic specimens; a frequency of 10 Hz is recommended for testing metallic specimens.

7.8 Set the testing machine or other instrument to give an indication if the vertical or horizontal component of the specimen deflection exceeds a preset value approximately 25 % greater than the deflection occurring in the first minute of running at test load.

If this indication is given by the testing machine or the instrument, terminate the test. Examine the embedding medium and the specimen to determine whether the specimen has loosened in the embedding medium or yield of the specimen has occurred.

7.9 Continue the test until one of the following events occurs :

- a) yield or loosening, as described in 7.8;
- b) fracture of the specimen;
- c) registration of completion of the chosen number of load cycles.

In each case, record the number of cycles.

7.10 Remove the specimen from the embedding medium.

7.11 Examine the test specimen, using the methods requested by the party that submitted the specimen for testing.

8 Test report

The test report shall include the following information :

- a) a reference to this part of ISO 7206;
- b) the identity of the test specimen, as stated by the party submitting the specimen for test;
- c) the embedding medium used;
- d) the minimum and maximum loads applied;
- e) the duration of the test, in cycles;
- f) the loading frequency;
- g) the head offset length, as designated in figure 3;
- h) a statement of results, including location of fracture (if applicable), description of test specimen at the end of the test, and the results of the examination requested by the party submitting the specimen for test;
- i) a record of if and why the test was terminated.

9 Disposal of test specimens

It is imperative that the prosthesis should not be used for clinical purposes after testing.

Care should be exercised in the use of the specimen for further mechanical tests because the loading regime may have altered the mechanical properties. In particular, it is recommended that the specimen is not used for further endurance testing.

Dimensions in millimetres

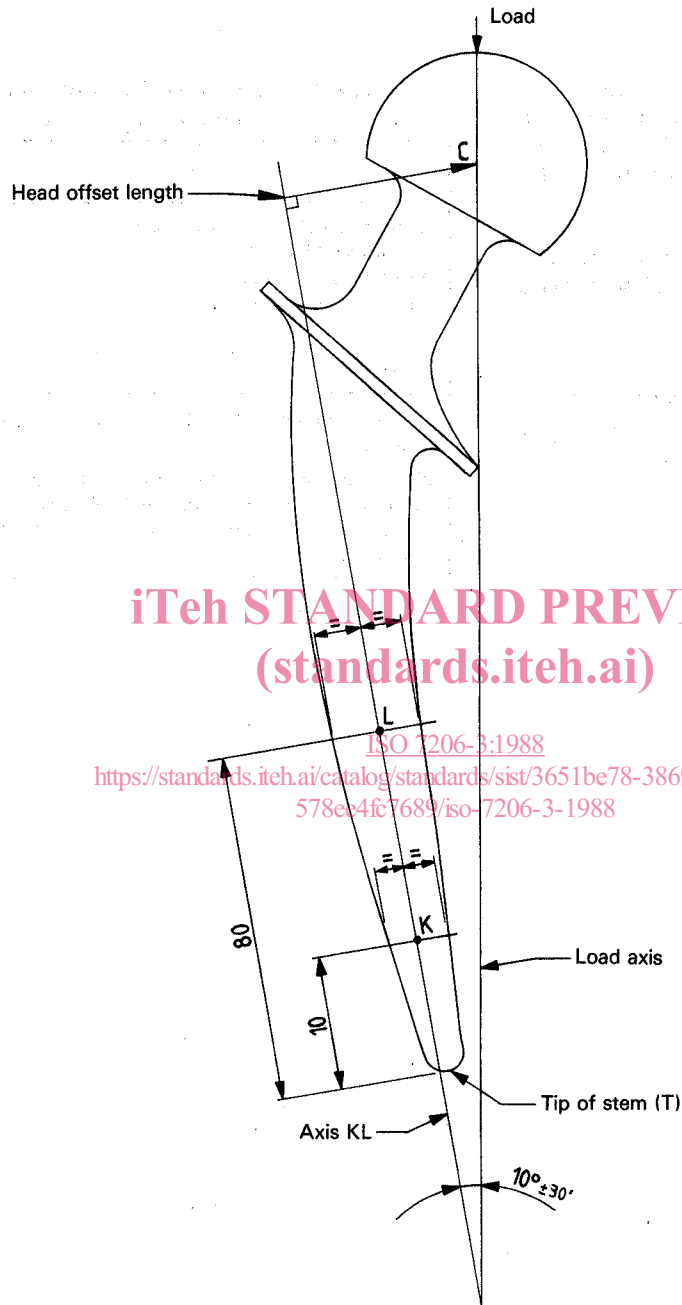

NOTE — Point C is as designated in ISO 7206-1. The orientation and reference points shown are for use with test specimens with and without a plateau.

Figure 3 — Orientation of specimen under test