



SLOVENSKI STANDARD
SIST EN 24049:2000
01-januar-2000

Dentistry - Resin-based filling materials (ISO 4049:1988 + Technical corrigendum 1:1992)

Dentistry - Resin-based filling materials (ISO 4049:1988 + Technical corrigendum 1:1992)

Zahnheilkunde - Füllungskunststoffe (ISO 4049:1988 + Technische Korrektur 1:1992)

Art dentaire - Produits d'obturation à base de résines synthétiques (ISO 4049:1988 + Rectificatif technique 1:1992)

iTeh STANDARD PREVIEW
(standards.iteh.ai)

[SIST EN 24049:2000](https://standards.iteh.ai/catalog/standards/sist/753d3b45-cf77-4290-8f4e-895d6511b5ce/sist-en-24049-2000)

Ta slovenski standard je istoveten z: EN 24049:1993

ICS:

11.060.10 Zl [c @ ã } ã æ ! ã ã Dental materials

SIST EN 24049:2000 en

iTeh STANDARD PREVIEW
(standards.iteh.ai)

SIST EN 24049:2000

<https://standards.iteh.ai/catalog/standards/sist/753d3b45-cf77-4290-8f4e-895d6511b5ce/sist-en-24049-2000>

EUROPEAN STANDARD

EN 24049:1992

NORME EUROPÉENNE

EUROPÄISCHE NORM

July 1992

UDC 616.314-089.27 : 615.462

Descriptors: Dentistry, dental materials, dental cements, synthetic resins, specifications, tests, packing, marking

English version

**Dentistry - Resin-based filling materials (ISO 4049,
edition 1988)**Art dentaire - Produits d'obturation à base de
résines synthétiques (ISO 4049, édition 1988)Zahnheilkunde - Füllungswerkstoffe aus
Kunststoff (ISO 4049, Ausgabe 1988)STANDARD PREVIEW
(standard.iteh.ai)REPUBLIKA SLOVENIJA
MINISTRSTVO ZA ZNANOST IN TEHNOLOGIJO
Urad RS za standardizacijo in meroslovje
LJUBLJANASIST... EN 24049
PREVZET PO METODI RAZGLASITVE

-01- 2000

This European Standard was approved by CEN on 1992-07-27. CEN members are bound to comply with the CEN/CENELEC Internal Regulations which stipulate the conditions for giving this European Standard the status of a national standard without any alteration.

Up-to-date lists and bibliographical references concerning such national standards may be obtained on application to the Central Secretariat or to any CEN member.

The European Standards exist in three official versions (English, French, German). A version in any other language made by translation under the responsibility of a CEN member into its own language and notified to the Central Secretariat has the same status as the official versions.

CEN members are the national standards bodies of Austria, Belgium, Denmark, Finland, France, Germany, Greece, Iceland, Ireland, Italy, Luxembourg, Netherlands, Norway, Portugal, Spain, Sweden, Switzerland and United Kingdom.

CENEuropean Committee for Standardization
Comité Européen de Normalisation
Europäisches Komitee für Normung

Central Secretariat: rue de Stassart, 36 B-1050 Brussels

Page 2
EN 24049:1992

Foreword

This European Standard has been taken over by CEN/TC 55 "Dentistry" from the work of ISO/TC 106 "Dentistry" of the International Organization for Standardization (ISO).

In the countries bound to implement this European Standard a national standard identical to this European Standard shall be published at the latest by 1993-02-28 and conflicting national standards shall be withdrawn at the latest by 1993-02-28.

According to the CEN/CENELEC Common Rules, the following countries are bound this European Standard : Austria, Belgium, Denmark, Finland, France, Germany, Greece, Iceland, Ireland, Italy, Luxembourg, Netherlands, Norway, Portugal, Spain, Sweden, Switzerland and United Kingdom.

iTeh STANDARD PREVIEW
Endorsement notice
(standards.iteh.ai)

The text of the International Standard ISO 4049:1988 was approved by CEN as a European Standard without any modification.

<https://standards.iteh.ai/catalog/standards/sist/753d3b45-cf77-4290-8fe-895d6511b5ce/sist-en-24049-2000>

INTERNATIONAL STANDARD

ISO
4049

Deuxième édition
1988-12-15



INTERNATIONAL ORGANIZATION FOR STANDARDIZATION
ORGANISATION INTERNATIONALE DE NORMALISATION
МЕЖДУНАРОДНАЯ ОРГАНИЗАЦИЯ ПО СТАНДАРТИЗАЦИИ

Dentistry — Resin-based filling materials

Art dentaire — Produits d'obturation à base de résines synthétiques

iTeh STANDARD PREVIEW
(standards.iteh.ai)

[SIST EN 24049:2000](https://standards.iteh.ai/catalog/standards/sist/753d3b45-cf77-4290-8f4e-895d6511b5ce/sist-en-24049-2000)

<https://standards.iteh.ai/catalog/standards/sist/753d3b45-cf77-4290-8f4e-895d6511b5ce/sist-en-24049-2000>

ISO 4049 : 1988 (E)

Foreword

ISO (the International Organization for Standardization) is a worldwide federation of national standards bodies (ISO member bodies). The work of preparing International Standards is normally carried out through ISO technical committees. Each member body interested in a subject for which a technical committee has been established has the right to be represented on that committee. International organizations, governmental and non-governmental, in liaison with ISO, also take part in the work. ISO collaborates closely with the International Electrotechnical Commission (IEC) on all matters of electrotechnical standardization.

Draft International Standards adopted by the technical committees are circulated to the member bodies for approval before their acceptance as International Standards by the ISO Council. They are approved in accordance with ISO procedures requiring at least 75 % approval by the member bodies voting.

International Standard ISO 4049 was prepared by Technical Committee ISO/TC 106, *Dentistry*.

This second edition cancels and replaces the first edition (ISO 4049 : 1978), of which it constitutes a technical revision (see the Introduction).

[SIST EN 24049:2000](https://standards.iteh.ai/catalog/standards/sist/753d3b45-cf77-4290-8f4e-895d6511b5ce/sist-en-24049-2000)

<https://standards.iteh.ai/catalog/standards/sist/753d3b45-cf77-4290-8f4e-895d6511b5ce/sist-en-24049-2000>

Introduction

This second edition of ISO 4049 takes account of the considerable volume of technical information which has accumulated since the first edition was published in 1978. Some of the tests in the first edition have been omitted and others added for the reasons given below.

This International Standard does not cover requirements for materials intended for the restoration of occlusal surfaces or those intended to prevent caries. In order to make this clear, a classification system has been introduced (see clause 3). This International Standard therefore covers class B materials, i.e. materials other than those intended for occlusal surfaces, and manufacturers are now required to classify their materials accordingly. Furthermore, in order to assist the purchaser, manufacturers are now also required (see clause 8) to describe the filler particle size range and the principal component of the resin base.

The possibility was considered that materials might be classified by filler loading or its corollary, water uptake, and solubility of the resin phase. However collaborative testing revealed considerable overlapping of these properties in "conventional" and "microfine" materials and such a classification was not adopted.

Resin-based restorative materials activated by external energy are now well established and requirements for these materials are therefore included. As the materials do not have an unlimited working time in the dental surgery, a test for sensitivity to ambient light has been included (see 7.6).

Working and setting times of chemically cured materials cannot be determined accurately because of their rapid setting and varying viscosities after mixing. The test in the first edition of this International Standard, using an oscillating rheometer, had poor sensitivity and gave results that could not be correlated with "clinical" working time. In this second edition the test has been replaced by one which is simple and widely applicable.

The flexural strength test (see 7.8) has been aligned with the test used for denture-base polymers by requiring that the specimen be immersed in water during testing. A requirement relating to modulus-dependent flexural strength has been included with the limiting value set to reveal conventional composites with poor filler/resin bonding.

Requirements have been included for materials claimed to be radio-opaque (see 4.5).

Although tests are not included in this second edition for determining non-mandatory or optional properties, such as polymerization shrinkage, it is hoped to do so in a later edition. At present more than one test may be used to determine a single such property which makes true comparisons impossible and confuses the purchaser.

The test for depth of cure of external-energy-activated materials will be reviewed and revised, if necessary, when more data become available.

Specific qualitative and quantitative requirements for freedom from biological hazard are not included in this International Standard, but it is recommended that reference should be made to ISO/TR 7405 when assessing possible biological or toxicological hazards.

iTeh STANDARD PREVIEW
(standards.iteh.ai)

This page intentionally left blank

SIST EN 24049:2000

<https://standards.iteh.ai/catalog/standards/sist/753d3b45-cf77-4290-8f4e-895d6511b5ce/sist-en-24049-2000>

Dentistry — Resin-based filling materials

iTeh STANDARD PREVIEW (standards.iteh.ai)

1 Scope

This International Standard specifies requirements for dental resin-based restorative materials supplied in a form suitable for mechanical mixing, hand-mixing, or external energy activation, and intended for use primarily for the direct restoration of class III, IV and V cavities in the teeth, i.e. class B materials (see clause 3).

This International Standard does not cover requirements for materials intended for the restoration of occlusal surfaces, i.e. class A materials (see clause 3), or materials intended to prevent caries.

2 Normative references

The following standards contain provisions which, through reference in this text, constitute provisions of this International Standard. At the time of publication, the editions indicated were valid. All standards are subject to revision, and parties to agreements based on this International Standard are encouraged to investigate the possibility of applying the most recent editions of the standards listed below. Members of IEC and ISO maintain registers of currently valid International Standards.

ISO 3665 : 1976, *Photography — Intra-oral dental radiographic film — Specification*.

ISO/TR 7405 : 1984, *Biological evaluation of dental materials*.

ISO 7491 : 1985, *Dental materials — Determination of colour stability of dental polymeric materials*.

ISO 8601 : 1988, *Data elements and interchange formats — Information interchange — Representation of dates and times*.

3 Classification

For the purposes of this International Standard, dental resin-based restorative materials are classified as follows :

Class A : Materials claimed by the manufacturer as suitable for the restoration of cavities involving occlusal surfaces

Class B : All other materials

Type 1 : Chemically-cured materials, i.e. those materials where setting is effected by mixing an initiator and activator

Type 2 : External-energy-activated materials, i.e. those materials where setting is effected by the application of energy, such as blue light

4 Requirements

4.1 Biocompatibility

See the Introduction for guidance on biocompatibility.

4.2 Physical and mechanical properties

4.2.1 General

If the material is supplied by the manufacturer in pre-coloured standard shades, each shade shall be capable of satisfying the

ISO 4049 : 1988 (E)

requirements specified in 4.3 appropriate to the material type. If the material is supplied for "tinting" or "blending" to the user's prescription, the material shall comply with the requirements both when used alone and when used with the maximum recommended proportion of tinter or blender [see 8.3 g)].

4.2.2 Minimum working time, type 1 materials

The working time for type 1 materials, determined in accordance with 7.4, shall be not less than 90 s.

4.2.3 Setting time, type 1 materials

The setting time for type 1 materials, determined in accordance with 7.5, shall be not more than 5 min.

4.2.4 Sensitivity to ambient light, type 2 materials

When tested in accordance with 7.6, there shall be no detectable change in the consistency of any of the three samples of type 2 materials after being exposed to the test light for 60 s.

4.2.5 Depth of cure, type 2 materials

When determined in accordance with 7.7, the depth of cure of type 2 materials shall be not less than 2 mm, and, in any event, no more than 0,5 mm below the value stated by the manufacturer.

NOTE — This test is considered to represent about twice the optimal conversion of monomer to polymer.

4.2.6 Flexural strength

The flexural strength of type 1 and type 2 materials, determined in accordance with 7.8, shall be not lower than the value of $N = [(flexural\ modulus \times 0,002\ 5) + 40]$ MPa, and, in any event, not lower than 50 MPa.

4.2.7 Water absorption and solubility, types 1 and 2 materials

When determined in accordance with 7.9, the water absorption of type 1 and type 2 materials shall not be greater than $50\ \mu\text{g}/\text{mm}^3$ and the solubility shall not be greater than $5\ \mu\text{g}/\text{mm}^3$.

4.3 Shade

When the material is assessed in accordance with 7.10 by three observers, the shade of the set material shall match closely that of the manufacturer's shade guide. If a shade guide is not supplied by the manufacturer, samples from two further batches shall be taken for comparative purposes; all three samples shall show no more than a slight change in colour.

4.4 Colour stability

When the material is assessed in accordance with 7.10, none of the three observers shall observe more than a slight change in colour.

4.5 Radio-opacity

If the manufacturer claims that the material is radio-opaque [see 7.2.3.2 b)], the radio-opacity, determined in accordance with 7.11, shall be greater than that of the same thickness of aluminium.

5 Sampling

The test sample shall consist of retail packages from the same batch containing enough material to carry out the specified tests, plus an allowance for repeat tests, if necessary.

NOTE — 50 g should be sufficient, but two further samples of different batches may be required for the shade test (see 4.3).

6 Preparation of test specimens

NOTE — For the preparation of type 2 materials, reference should be made to the manufacturer's instructions [see 8.3 e)] which will state the external energy source or sources recommended for the materials to be tested. Care should be taken to ensure that the source is in a satisfactory operating condition.

Mix or otherwise prepare the material in accordance with the manufacturer's instructions and the test conditions specified in 7.2.

7 Test methods

7.1 General reagent and apparatus

7.1.1 Water

Water prepared by

- multiple distillation, or
- distillation followed by de-ionization, or
- distillation followed by reverse osmosis.

7.1.2 Glass slides/plates

Quartz glass plates, 2 mm thick, are required for use with type 2 materials being cured by ultraviolet light only. For type 1 materials and type 2 cured by blue light, standard glass microscope slides may be used.

7.2 Test conditions

Unless specified otherwise by the manufacturer, prepare and test all specimens at (23 ± 1) °C. Control the relative humidity to ensure that it remains greater than 30 % at all times. If the material was refrigerated for storage, allow sufficient time for it to attain (23 ± 1) °C.

7.3 Inspection

Visually inspect to check that requirements specified in clause 8 have been met.

Dimensions in millimetres

7.4 Working time, type 1 materials

7.4.1 Apparatus

Thermocouple apparatus, as shown in figure 1.

The apparatus consists of a piece of polyethylene tubing, (A), located on a block of polyamide or similar material, (B), which has a hole into which is inserted a stainless steel tube, (C), containing a stabilized thermocouple (D).

The tube (A) is 8 mm long, 4 mm in internal diameter and has a wall thickness of 1 mm. The locating part of block (B) is 4 mm in diameter and 2 mm high. When assembled the two components form a specimen well 6 mm high \times 4 mm in diameter. In order to facilitate removal of the specimen after testing, the thermocouple (D) has a conical tip which protrudes 1 mm into the base of the specimen well. The tolerances on the above-mentioned dimensions are $\pm 0,2$ mm.

The thermocouple consists of wires ($0,2 \pm 0,05$) mm in diameter, made of a material (e.g. copper/constantan) capable of registering temperature changes in a specimen of setting material to an accuracy of $0,1$ °C. The thermocouple is connected to an instrument (e.g. voltmeter or chart recorder) capable of recording the temperature to that accuracy.

7.4.2 Procedure

Prepare the test material in accordance with the manufacturer's instructions (see 8.3) and start timing from the moment mixing is begun. Maintain the mould at (23 ± 1) °C and 30 s after the start of mixing, place the mixed material in the mould and record the temperature, t_1 , of the material. Maintain the apparatus at (23 ± 1) °C and continuously record the temperature of the material until the peak temperature is passed.

NOTE — A typical recording trace is shown in figure 2. As soon as the material is inserted into the mould, the temperature falls slightly until it becomes steady at t_0 and then starts to increase. The point at which the temperature begins to increase denotes the start of the setting reaction and, therefore, the end of the working time. This point should be determined by drawing a proof line at $t_0 \pm 0,01$ °C and recording T_w at the point of intersection with the trace. The results are extremely temperature-dependent and slight variations within the permitted temperature range will cause variations of several seconds.

Record the time, T_w , from the start of mixing until the temperature starts to increase.

Carry out five determinations.

7.4.3 Interpretation of results

If at least four of the times obtained are longer than 90 s, the material is deemed to have complied with the requirement of 4.2.2.

If three or more of the times are shorter than 90 s, the material is deemed to have failed.

If only three times are longer than 90 s, repeat the whole test. If three or fewer times are longer than 90 s on the second occasion, the material is deemed to have failed the whole test.

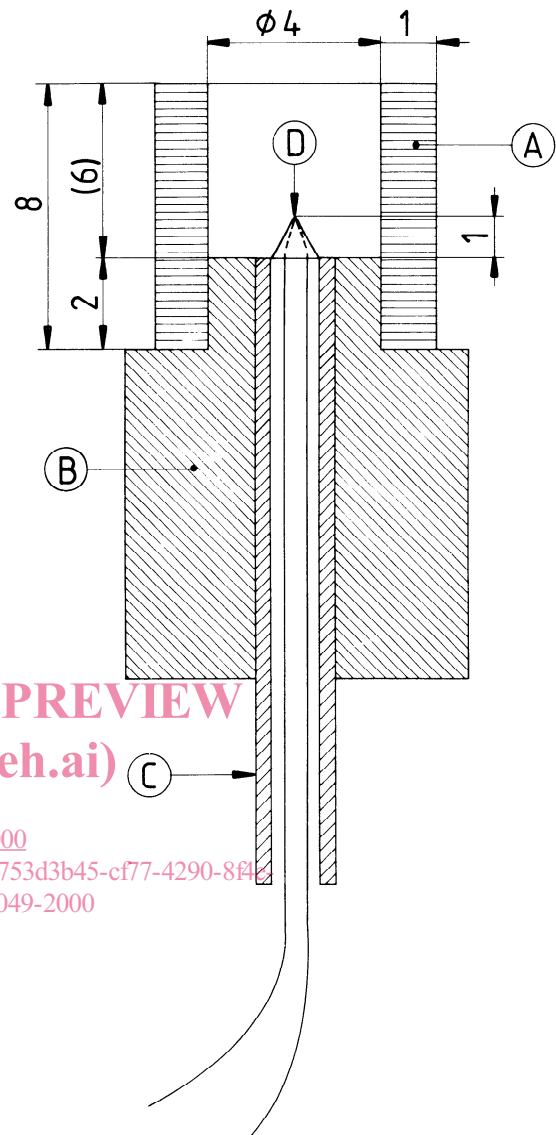

Key (see also 7.4.1)

- (A) Polyethylene tubing
- (B) Polyamide block
- (C) Stainless steel tube
- (D) Thermocouple-cone of solder

NOTE — Dimensional tolerances shall be $\pm 0,2$ mm.

Figure 1 — Apparatus for determination of working and setting times