

INTERNATIONAL
STANDARD

ISO
10807

First edition
1994-08-15

**Pipework — Corrugated flexible metallic
hose assemblies for the protection of
electrical cables in explosive atmospheres**

iTeh STANDARD PREVIEW

(standards.iteh.ai)
*Tuyauteries — Tuyauteries métalliques flexibles onduleuses destinées à
la protection de câbles électriques dans les atmosphères explosives*

ISO 10807:1994

<https://standards.iteh.ai/catalog/standards/sist/6a65ef4a-57d1-43ec-8b7f-66e58e6f9ada/iso-10807-1994>

INTERNATIONAL

ISO



Reference number
ISO 10807:1994(E)

Foreword

ISO (the International Organization for Standardization) is a worldwide federation of national standards bodies (ISO member bodies). The work of preparing International Standards is normally carried out through ISO technical committees. Each member body interested in a subject for which a technical committee has been established has the right to be represented on that committee. International organizations, governmental and non-governmental, in liaison with ISO, also take part in the work. ISO collaborates closely with the International Electrotechnical Commission (IEC) on all matters of electrotechnical standardization.

Draft International Standards adopted by the technical committees are circulated to the member bodies for voting. Publication as an International Standard requires approval by at least 75 % of the member bodies casting a vote.

International Standard ISO 10807 was prepared by Technical Committee ISO/TC 5, *Ferrous metal pipes and metallic fittings*, Subcommittee SC 11, *Flexible interlocked and convoluted metallic hoses*.

Annexes A and B form an integral part of this International Standard. Annex C is for information only.

© ISO 1994

All rights reserved. Unless otherwise specified, no part of this publication may be reproduced or utilized in any form or by any means, electronic or mechanical, including photocopying and microfilm, without permission in writing from the publisher.

International Organization for Standardization
Case Postale 56 • CH-1211 Genève 20 • Switzerland

Printed in Switzerland

Pipework — Corrugated flexible metallic hose assemblies for the protection of electrical cables in explosive atmospheres

1 Scope

This International Standard specifies the design characteristics of corrugated flexible metallic hose which can be used to protect electrical wire and cable in explosive atmospheres or atmospheres where there is a risk of fire. These hoses can be used as static protection or for the protection of cables moved infrequently, occasionally, or less than once week.

This International Standard also provides instructions for the use of these hoses (see annex A) and the tests required for type approval (see annex B).

2 Normative references

The following standards contain provisions which, through reference in this text, constitute provisions of this International Standard. At the time of publication, the editions indicated were valid. All standards are subject to revision, and parties to agreements based on this International Standard are encouraged to investigate the possibility of applying the most recent editions of the standards indicated below. Members of IEC and ISO maintain registers of currently valid International Standards.

ISO 7-1:1994, *Pipe threads where pressure-tight joints are made on the threads — Part 1: Dimensions, tolerances and designation.*

ISO 427:1983, *Wrought copper-tin alloys — Chemical composition and forms of wrought products.*

ISO 683-13:1986, *Heat-treatable steels, alloy steels and free-cutting steels — Part 13: Wrought stainless steels.*

ISO 1634-1:1987, *Wrought copper and copper alloy plate, sheet and strip — Part 1: Technical conditions of delivery for plate, sheet and strip for general purposes.*

ISO 4948-1:1982, *Steels — Classification — Part 1: Classification of steels into unalloyed and alloy steels based on chemical composition.*

ISO 4948-2:1981, *Steels — Classification — Part 2: Classification of unalloyed and alloy steels according to main quality classes and main property or application characteristics.*

ISO 6708:—¹⁾, *Pipe components — Definition of nominal size (DN).*

ISO 7369:—²⁾, *Pipework — Flexible metallic hoses — Vocabulary of general terms.*

3 Definitions

For the purposes of this International Standard, the definitions given in ISO 7369 apply.

4 Manufacturing process

The process for manufacturing leakproof corrugated flexible metallic hose complying with this International Standard is at the discretion of the manufacturer.

1) To be published. (Revision of ISO 6708:1980)

2) To be published. (Revision of ISO 7369:1983)

5 Materials

5.1 Metallic hose

The metallic hose shall be manufactured from either

- a) copper alloy with copper content 94 % or above, in accordance with ISO 1634, or
- b) austenitic stainless steel, in accordance with ISO 683-13.

5.2 End fittings

End fittings shall be manufactured from either

- a) steel corresponding to the classification of non-alloy steels given in ISO 4948-1 and ISO 4948-2, or
- b) austenitic stainless steel, in accordance with ISO 683-13.

5.3 Braiding

Braiding shall be carried out using either

- a) bronze wire in accordance with ISO 427, or
- b) austenitic stainless steel, in accordance with ISO 683-13.

5.4 Welding

Hose components can be joined by

- a) braze welding;
- b) electric welding (MIG, MAG, TIG), microplasma welding (MP) or impulse welding.

Adhesive bonding and tin soldering are excluded.

6 Dimensions and performance

6.1 The dimensions and performance of corrugated flexible metallic hose complying with this International Standard are given in table 1.

6.2 The dimensions of end fittings and the lengths of hoses are shown in figure 1 and given in table 2.

The external shape of the end fitting may be polygonal or with notches for a sector wrench.

Table 1 — Dimensions and performance of flexible metallic hose in explosive atmospheres
Dimensions in millimetres

| Nominal size ¹⁾ DN | Minimum internal diameter | Maximum value of minimum dynamic bend radius | Maximum value of minimum static bend radius |
|----------------------------------|---------------------------|--|---|
| 15 | 14 | 270 | 50 |
| 20 | 18 | 280 | 70 |
| 25 | 23 | 310 | 90 |
| 32 ²⁾ | 29 | 320 | 110 |
| 40 | 37 | 400 | 130 |
| 50 | 48 | 500 | 175 |
| 65 ²⁾ | 60 | 600 | 200 |
| 80 | 75 | 750 | 240 |
| 100 | 95 | 900 | 300 |

1) See ISO 6708.
2) DN with limited application.

iTeh STANDARD PREVIEW
(standards.iteh.ai)

7 Inspection and testing

7.1 General

The hose assemblies shall be subjected by the manufacturer to the inspections and tests specified in 7.2 to 7.4 (see also annex B).

7.2 Dimensional inspection

All hose assemblies shall comply with the requirements of tables 1 and 2.

7.3 Visual examination

All hose assemblies shall comply with the requirements of 8.3.

7.4 Hydraulic test

Each hose assembly shall be subjected to a hydraulic test under a minimum pressure of 40 bar with a nonaggressive fluid for a period of at least 60 s.

There shall be no leakage.

After testing, the hose shall be cleaned and dried.

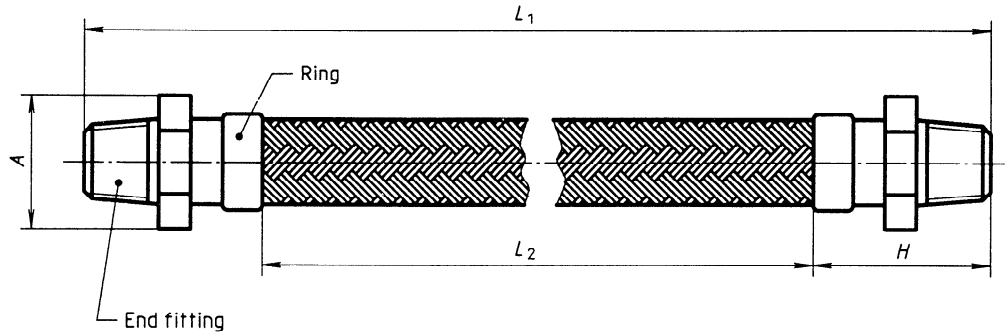

Figure 1

Table 2 — Dimensions of end fittings and hose lengths

Dimensions in millimetres

| Nominal size DN | Thread ¹⁾ | Total hose lengths ²⁾ | | | | | | | | | A max. | H max. |
|--------------------|----------------------|----------------------------------|-----|-----|-----|-----|-----|-----|-------|-------|-----------|-----------|
| | | 300 | 400 | 425 | 600 | 700 | 800 | 900 | 1 000 | 1 200 | | |
| 15 | R 1/2 | xxx | — | xxx | xxx | — | xxx | — | — | — | 34 | 60 |
| 20 | R 3/4 | xxx | — | xxx | — | xxx | — | — | xxx | — | 40 | 60 |
| 25 | R 1 | — | xxx | — | — | xxx | — | — | xxx | — | 50 | 70 |
| 32 ³⁾ | R 1 1/4 | — | — | — | — | — | — | — | — | — | — | — |
| 40 | R 1 1/2 | — | xxx | — | — | — | xxx | — | — | xxx | 68 | 80 |
| 50 | R 2 | — | xxx | — | — | — | — | xxx | — | xxx | 82 | 80 |
| 65 ³⁾ | R 2 1/2 | — | — | — | — | — | — | — | — | — | — | — |
| 80 | R 3 | — | — | — | — | — | — | xxx | — | xxx | 120 | 100 |
| 100 | R 4 | — | — | — | — | — | — | — | — | xxx | 145 | 130 |

1) In accordance with ISO 7-1.

2) The overall length of a flexible hose is the length ordered with a tolerance of $\begin{matrix} +3 \\ -1 \end{matrix}$ %.

3) DN with limited application.

8 Technical delivery conditions

8.1 Types of delivery

Corrugated flexible metallic hose assemblies complying with this International Standard are delivered ready-fitted with two fixed male end fittings.

8.2 Surface protection

Stainless steel end fittings are not protected; non-alloyed steel fittings are galvanized or painted with a zinc-epoxy primer.

8.3 Finish

The internal surfaces of the hose and fittings shall be free from burrs and sharp edges likely to damage the electric cable.

8.4 Thread

In accordance with ISO 7-1.

9 Marking

9.1 The corrugated flexible metallic hose assemblies shall be marked indelibly on one of the end fittings, on one of the two rings or on a nondetachable metal collar.

The marking shall include the following information:

- manufacturer's name or factory mark;
- reference to this International Standard;
- the last two figures of the year of production;
- the class of location (see A.2).

EXAMPLE

XY - ISO 10807 - 94 - B

9.2 By agreement between the parties at the time of ordering, other marking conditions may be specified (see B.4).

10 Designation and ordering

10.1 Required information

A corrugated flexible metallic hose assembly complying with this International Standard shall be designated and/or ordered by following information, in the sequence given:

- a) the group of five letters: TMFAE (Flexible Metallic Hose in Explosive Atmospheres);
- b) reference to this International Standard;
- c) nominal size (see table 1);
- d) total length, L_1 , in millimetres (see table 2);
- e) nature of the materials used (see clause 5);
- f) class of location (see A.2).

EXAMPLE

Designation of a corrugated flexible metallic hose assembly of nominal size DN 40 and length 800 mm, of austenitic stainless steel used in a class B location:

TMFAE ISO 10807 DN40 - 800 - stainless steel - B

10.2 Optional information

The order for corrugated metallic hose complying with this International Standard may also contain a request by the purchaser for:

- a special type of marking (see 9.2);
- documentation in accordance with ISO 404.

Annex A (normative)

Instructions for use

A.1 Scope

This annex provides some helpful instructions on the use of corrugated flexible metallic hose for the protection of electrical cables in flame-resistant installations, regarding the local atmosphere and the choice of materials in relation to the conditions of use.

A.2 Classification of locations

The local atmosphere in which the corrugated flexible metallic hose is to be used can be categorized into one of the three classes given in A.2.1 to A.2.3.

A.2.1 Class A: Closed or covered locations such as industrial premises, sheds protected from atmospheric or corrosive agents (sea air, slightly acid atmosphere, etc.).

A.2.2 Class B: Closed or open locations exposed to corrosive agents (i.e. close to the sea, acid atmosphere, etc.).

A.2.3 Class C: Any other location containing highly corrosive atmospheres.

Corrosive agents are all those likely to corrode the

materials of the corrugated flexible metallic hose assemblies specified in this International Standard and their components: fittings, welding or brazing filler materials, sleeves, braiding and hose.

EXAMPLES

An atmosphere in which ammonia is present is incompatible with all copper alloys.

An atmosphere in which hydrochloric acid is present is incompatible with most stainless steels. In this case, subsequent protection of the hoses should be provided.

A.3 Choice of materials

Materials shall be chosen according to the class of location, as shown below:

- for class A, the materials described in clause 5;
- for class B, the materials described in 5.1 b), 5.2 b), 5.3 b) and 5.4;
- for class C, the steels of type 19, 20 and 21 in accordance with ISO 683-12 and welding in accordance with 5.4 b).

Annex B (normative)

Type approval testing

B.1 Scope

This annex specifies the tests required by officially approved agencies for the type approval of corrugated metallic hose for the protection of electrical cables in flameproof installations.

B.2 Tests

B.2.1 General

Each type of hose shall successfully undergo the tests described in B.2.2 and B.2.3.

These tests are carried out on hoses assembled in accordance with figure 1 and table 2, taking four samples per diameter, the minimum length of one of these samples being given in table B.1, those of the other three samples being given in table B.2 for flexural strength and bending fatigue tests, respectively.

B.2.2 Flexural strength test of hoses intended for static installation

B.2.2.1 The hose, one of the ends of which shall be held firmly at the end fitting, shall be placed (see figure B.1) between two shaping cylinders of diameter given in table B.1.

The horizontal axis of the shaping cylinders shall be in the same plane as the first corrugation of the hose. Care should be taken that the corrugation is not flattened or otherwise damaged.

The corrugated hose shall be bent over one of the shaping cylinders, with contact made over 90° of its circumference, to attain the starting position for the test, position A in figure B.1.

Taking approximately 10 s, the end fitting shall be drawn in a smooth movement through a 180° arc to the mirror position, with contact made over 90° of the circumference of the cylinder, position B in figure B.1.

The hose shall be returned to position A in the same manner. This movement shall be repeated thirty times, each 180° movement representing one bending cycle.

The test shall be carried out once for each diameter.

B.2.2.2 After the flexural strength test, the hose shall be subjected to the hydraulic test in accordance with 7.4.

B.2.3 Bending fatigue test on hose

B.2.3.1 Three samples for each diameter, up to and including DN 50, shall be subjected to the fatigue test as shown in figure B.2. The test shall be carried out at a pressure of 1 bar, with the distance between centres being that given in table B.2.

The hose shall be subjected to repeated bending movements, at a rate of 40 cycles/min up to 120 cycles/min in a direction parallel to the axis of the hose, the total displacement being 250 mm.

The number of cycles before failure shall not be less than 10 000.

B.2.3.2 After the fatigue test, the hose shall be subjected to the hydraulic test in accordance with 7.4.

B.3 Certification

Approved hose shall be delivered with the certificates of conformity supplied by the agency authorized to perform the examination of the products.

B.4 Marking

Approved hose shall bear the symbols given in 9.1 and also the mark required by the officially approved agency.

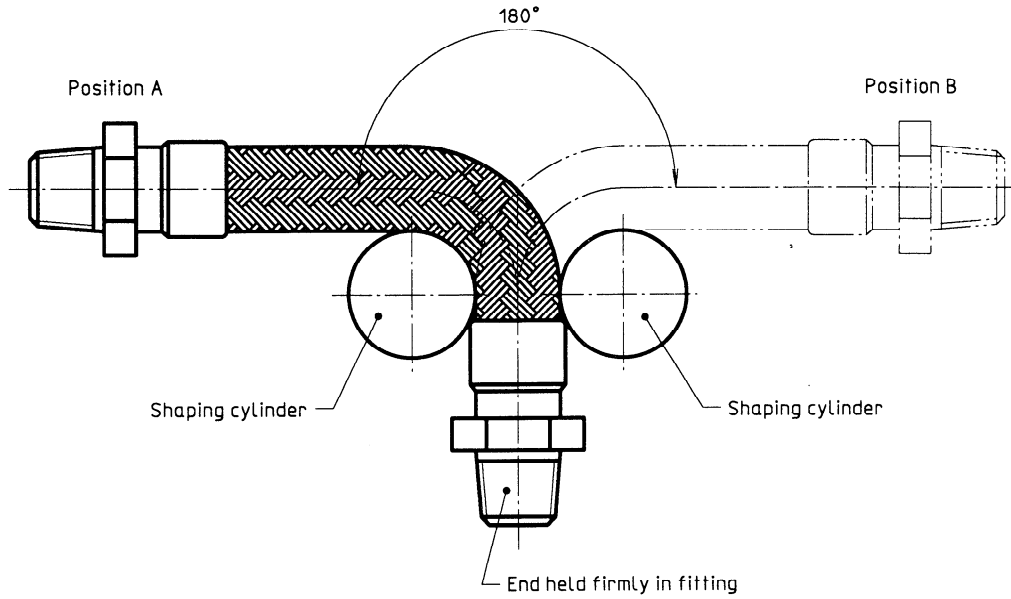

Figure B.1 — Flexural strength test

iTeh STANDARD PREVIEW
(standards.iteh.ai)

ISO 10807:1994
Table B.1 — Flexural strength test
Dimensions in millimetres
<https://standards.iteh.ai/catalog/standards/sist/6a65e14a-57d1-53ec-8b7f-66c58c6Dada/iso-10807-1994>

| Nominal size DN | Length of hose between rings L_2 ¹⁾ | Diameter of shaping cylinder |
|--------------------|--|---------------------------------|
| 15 | 150 | 38 |
| 20 | 150 | 50 |
| 25 | 200 | 68 |
| 32 | 250 | 80 |
| 40 | 320 | 100 |
| 50 | 350 | 125 |
| 65 | 400 | 170 |
| 80 | 500 | 200 |
| 100 | 600 | 250 |

1) See figure 1.