

---

# International Standard



# 7228

---

INTERNATIONAL ORGANIZATION FOR STANDARDIZATION • МЕЖДУНАРОДНАЯ ОРГАНИЗАЦИЯ ПО СТАНДАРТИЗАЦИИ • ORGANISATION INTERNATIONALE DE NORMALISATION

---

## Tracheal tube connectors

*Raccords de tubes trachéaux*

Second edition — 1985-07-01

**iTeh STANDARD PREVIEW**  
**(standards.iteh.ai)**

ISO 7228:1985

<https://standards.iteh.ai/catalog/standards/sist/03f0ad1f-13c7-4377-911b-e03296e62835/iso-7228-1985>

---

UDC 621.643.41 : 616.231-089.5

Ref. No. ISO 7228-1985 (E)

Descriptors : medical equipment, anaesthesia, artificial breathing apparatus, specifications, pipes (tubes), connectors.

Price based on 3 pages

## Foreword

ISO (the International Organization for Standardization) is a worldwide federation of national standards bodies (ISO member bodies). The work of preparing International Standards is normally carried out through ISO technical committees. Each member body interested in a subject for which a technical committee has been established has the right to be represented on that committee. International organizations, governmental and non-governmental, in liaison with ISO, also take part in the work.

Draft International Standards adopted by the technical committees are circulated to the member bodies for approval before their acceptance as International Standards by the ISO Council. They are approved in accordance with ISO procedures requiring at least 75 % approval by the member bodies voting.

International Standard ISO 7228 was prepared by Technical Committee ISO/TC 121, *Anaesthetic equipment and medical breathing machines*.

ISO 7228 was first published in 1981. This second edition cancels and replaces the first edition, the following sub-clause of the previous edition has been technically revised : 7.2 (deletion also of figure 3).

**ITeH STANDARD PREVIEW**  
(standards.iteh.ai)

<https://standards.iteh.ai/catalog/standards/sis/7059/iso-13c7-4377-911b-e03296e62835/iso-7228-1985>

# Tracheal tube connectors

## 0 Introduction

The purpose of this International Standard is to promote interchangeability of tracheal tube connectors without dealing with details of design.

ISO 5356/1 lays down the dimensions and sequence of conical connections for the breathing attachments of anaesthetic machines and ventilators. It deals only briefly with tracheal tube connectors and notes that there is a wide variety of acceptable designs to suit different clinical situations. It also notes that some of these connectors will need intermediate adaptors and elastomeric tube to join them to the patient connecting port of the breathing system. The latter port is a coaxial 22 mm male/15 mm female fitting and it follows, as prescribed in 5356/1, that the machine end of such adaptors and of tracheal tube connectors may be 22 mm female or 15 mm male. While the 22 mm female fitting is widely used for adaptors, which are not considered in this International Standard, it is very rarely used for tracheal tube connectors.

The main purpose is to facilitate the work of the user, and thus the safety of the patient, by prescribing that the designated size of each connector shall be the same as that of the tracheal tube (as prescribed in ISO 5366/1) with which it is designed to fit.

## 1 Scope and field of application

This International Standard specifies basic requirements for tracheal tube connectors, including size designation.

## 2 References

ISO 5356/1, *Breathing attachments for inhalation anaesthetic apparatus, lung ventilators and resuscitators — Part 1: Conical fittings and adaptors for breathing systems*.<sup>1)</sup>

ISO 5366/1, *Tracheostomy tubes — Part 1: Connectors*.

## 3 Definitions

For the purpose of this International Standard, the following definitions apply.

**3.1 tracheal tube connector** : Tubular component that fits directly into the tracheal tube.

**3.2 patient end** : End of the component nearest to the patient which is inserted into the tracheal tube.

**3.3 machine end** : End of the component nearest to the machine.

## 4 Size designation

The nominal size of the connector shall be designated by its internal diameter in accordance with the table.

## 5 Size range

The size range shall be from 2,5 to 11,0 mm in accordance with the table.

## 6 Materials

**6.1** The connector shall be made of material which is reasonably resistant to the action of anaesthetic gases and vapours.

**6.2** Unless designated for single use, the connector shall be resistant to deterioration by normal methods of cleaning, disinfection and sterilization as recommended by the manufacturer or supplier. It is desirable that any connector not designated for single use shall withstand accepted methods of steam sterilization.

1) At present at the stage of draft.

## 7 Design

### 7.1 General

7.1.1 The connector may be straight, curved or angled. If curved or angled, the connector may incorporate a suction port. This port shall be designed so that its closure does not obstruct or narrow the lumen of the connector.

7.1.2 Basic dimensions shall be in accordance with the table.

7.1.3 The connector shall be light in weight but shall be of sufficient strength to resist deformation under normal conditions of use.

7.1.4 The connector shall be designed to have minimal dead space and to give a minimal resistance to gaseous flow. The lumen shall be smooth and free from ridges.

7.1.5 Tracheal tube connectors may be provided with lugs, flats, or other means to facilitate connection and disconnection, provided that any protrusions are well rounded.

7.1.6 The cross-sectional area of the lumen throughout a straight connector shall be not less than that of the corresponding tracheal tube into which the connector is designed to fit.

The minimum internal diameter of a curved or angled connector shall be not less than 80 % of the original nominal diameter and the corresponding cross-sectional area shall not be reduced by more than 10 %.

### 7.2 Machine end

The machine end of tracheal tube connectors shall be in accordance with one of the following :

a) male 15 mm conical fitting in accordance with ISO 5356/1. The internal diameter of the (conical) machine end shall be not less than that of the patient end (i.e. not less than the size of the connector). Any transition in the internal diameter shall be tapered to give an adequate lead in for smooth passage of a suction catheter.

b) female 22 mm conical fitting in accordance with ISO 5356/1 (not shown in figures);

### 7.3 Patient end

The basic dimensions of the patient end (see figures 1 and 2) of the connector shall be in accordance with the table.

## 8 Marking

The connectors shall be clearly marked with the size designated in accordance with clause 4.

ISO 7228:1985

<https://standards.iteh.ai/catalog/standards/sist/03f0ad1f-13c7-4377-911b-e03296e62835/iso-7228-1985>

Table — Tracheal connectors — Size range and basic dimensions of patient end

Dimensions in millimetres

Size (designated in accordance with clause 4)	Internal diameter <i>d</i>	Straight connectors (see figure 1, dimension <i>l</i> <sub>1</sub> )	Curved connectors (see figure 2, dimension <i>l</i> <sub>2</sub> )
2,5	2,5 ± 0,15	11 ± 2	—
3,0	3,0 ± 0,15	11 ± 2	—
3,5	3,5 ± 0,15	13 ± 2	—
4,0	4,0 ± 0,15	13 ± 2	—
4,5	4,5 ± 0,15	14 ± 2	—
5,0	5,0 ± 0,15	14 ± 2	—
5,5	5,5 ± 0,15	15 ± 2	10 ± 2
6,0	6,0 ± 0,15	15 ± 2	10 ± 2
6,5	6,5 ± 0,15	18 ± 2	10 ± 2
7,0	7,0 ± 0,15	18 ± 2	10 ± 2
7,5	7,5 ± 0,15	18 ± 2	10 ± 2
8,0	8,0 ± 0,15	18 ± 2	10 ± 2
8,5	8,5 ± 0,15	18 ± 2	10 ± 2
9,0	9,0 ± 0,15	18 ± 2	10 ± 2
9,5	9,5 ± 0,15	18 ± 2	10 ± 2
10,0	10,0 ± 0,15	18 ± 2	10 ± 2
11,0	11,0 ± 0,15	18 ± 2	10 ± 2

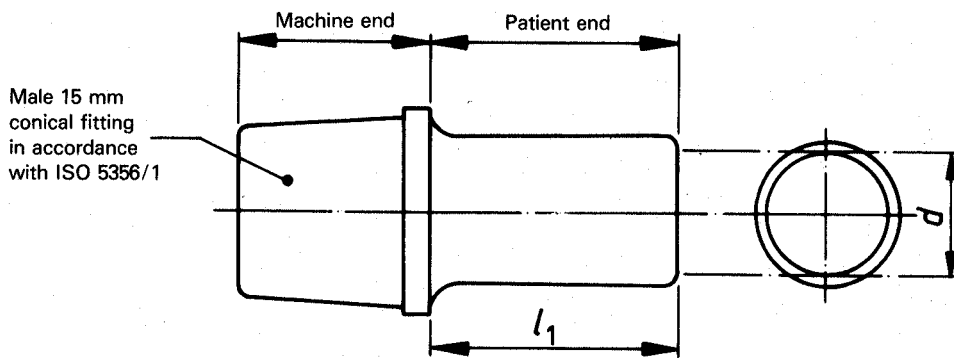

Figure 1 – Straight tracheal tube connector

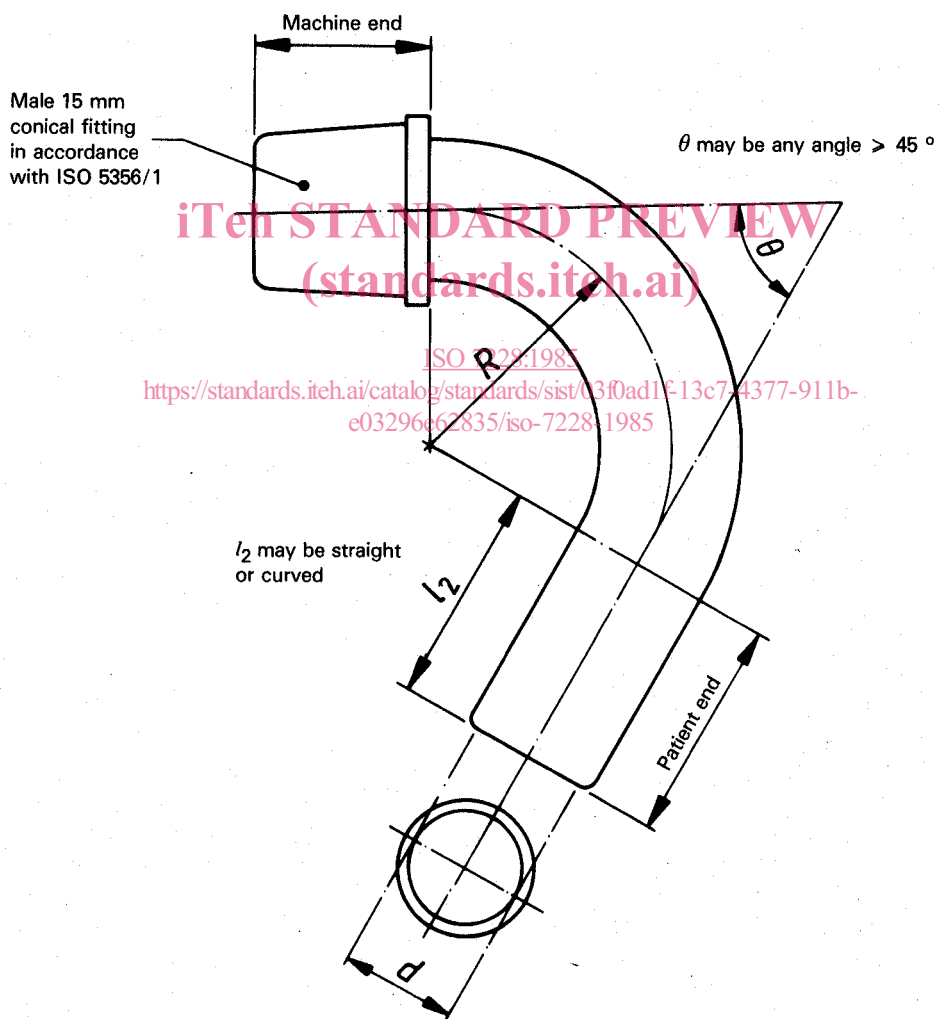

Figure 2 – Example of a curved tracheal tube connector

NOTE — Figures 1 and 2 illustrate tracheal tube connectors for the purpose of defining basic dimensions but the illustrated designs do not otherwise form a part of this specification.