

INTERNATIONAL STANDARD

ISO
7241-1

First edition
1987-04-01



INTERNATIONAL ORGANIZATION FOR STANDARDIZATION
ORGANISATION INTERNATIONALE DE NORMALISATION
МЕЖДУНАРОДНАЯ ОРГАНИЗАЦИЯ ПО СТАНДАРТИЗАЦИИ

Hydraulic fluid power — Quick-action couplings —

Part 1 : Dimensions and requirements

ITEH STANDARD PREVIEW
(standards.iteh.ai)

Transmissions hydrauliques — Raccords rapides —

Partie 1 : Dimensions et spécifications [ISO 7241-1:1987](#)

<https://standards.iteh.ai/catalog/standards/sist/3b30557a-8bee-4738-afa6-e780e1788f87/iso-7241-1-1987>

Reference number
ISO 7241-1 : 1987 (E)

Foreword

ISO (the International Organization for Standardization) is a worldwide federation of national standards bodies (ISO member bodies). The work of preparing International Standards is normally carried out through ISO technical committees. Each member body interested in a subject for which a technical committee has been established has the right to be represented on that committee. International organizations, governmental and non-governmental, in liaison with ISO, also take part in the work.

Draft International Standards adopted by the technical committees are circulated to the member bodies for approval before their acceptance as International Standards by the ISO Council. They are approved in accordance with ISO procedures requiring at least 75 % approval by the member bodies voting.

International Standard ISO 7241-1 was prepared by Technical Committee ISO/TC 131, *Fluid power systems*.

Users should note that all International Standards undergo revision from time to time and that any reference made herein to any other International Standard implies its latest edition, unless otherwise stated.

ITeH STANDARD PREVIEW

(standards.iteh.ai)

ISO 7241-1:1987
<http://standards.iteh.ai/catalog/standards/sist/31192557a-8bee-4738-afa6-e780e1788f87/iso-7241-1-1987>

Hydraulic fluid power — Quick-action couplings —

Part 1 : Dimensions and requirements

0 Introduction

In hydraulic fluid power systems, power is transmitted and controlled through a liquid under pressure within an enclosed circuit. Quick-action couplings are used to join or separate quickly fluid conducting lines, without the use of tools or special devices.

1 Scope and field of application

This part of ISO 7241 lays down the interface dimensions and specifies basic performance requirements for two series of general-purpose hydraulic quick-action couplings. Both series are in widespread use and have similar technological advantages. The distinction in usage is mainly geographical. Series "A" is used predominantly in Europe and series "B" is predominant in America.

2 References

ISO 2944, *Fluid power systems and components — Nominal pressures.*

ISO 4397, *Fluid power systems and components — Connectors and associated components — Outside diameters of tubes and inside diameters of hoses.*

ISO 5598, *Fluid power systems and components — Vocabulary.*

ISO 5675, *Agricultural tractors and machinery — Hydraulic couplers for general purposes — Specifications.*

ISO 7241-2, *Hydraulic fluid power — Quick-action couplings — Part 2: Test methods.*

3 Definitions

For the purposes of this part of ISO 7241, the definitions given in ISO 5598 apply.

4 Dimensional requirements

4.1 Series "A" dimensional requirements are shown in figure 1 and given in table 1.

4.2 Series "B" dimensional requirements are shown in figures 2 and 3, and given in tables 2 and 3.

5 Performance requirements

5.1 Pressure rating requirements are given in table 4.

5.2 Recommended maximum internal pressure for connecting the coupling by hand is given in table 5.

6 Summary of information to be supplied

The quick-action coupling "series" and coupling "size" shall be stated when applying this part of ISO 7241 to a particular use.

7 Identification statement (Reference to this International Standard)

Use the following statement in test reports, catalogues and sales literature when electing to comply with this part of ISO 7241:

"Dimensional and pressure requirements conform to ISO 7241-1¹⁾, *Hydraulic fluid power — Quick-action couplings — Part 1: Dimensions and requirements.*"

1) Specify "A" or "B".

Surface roughness values in micrometres

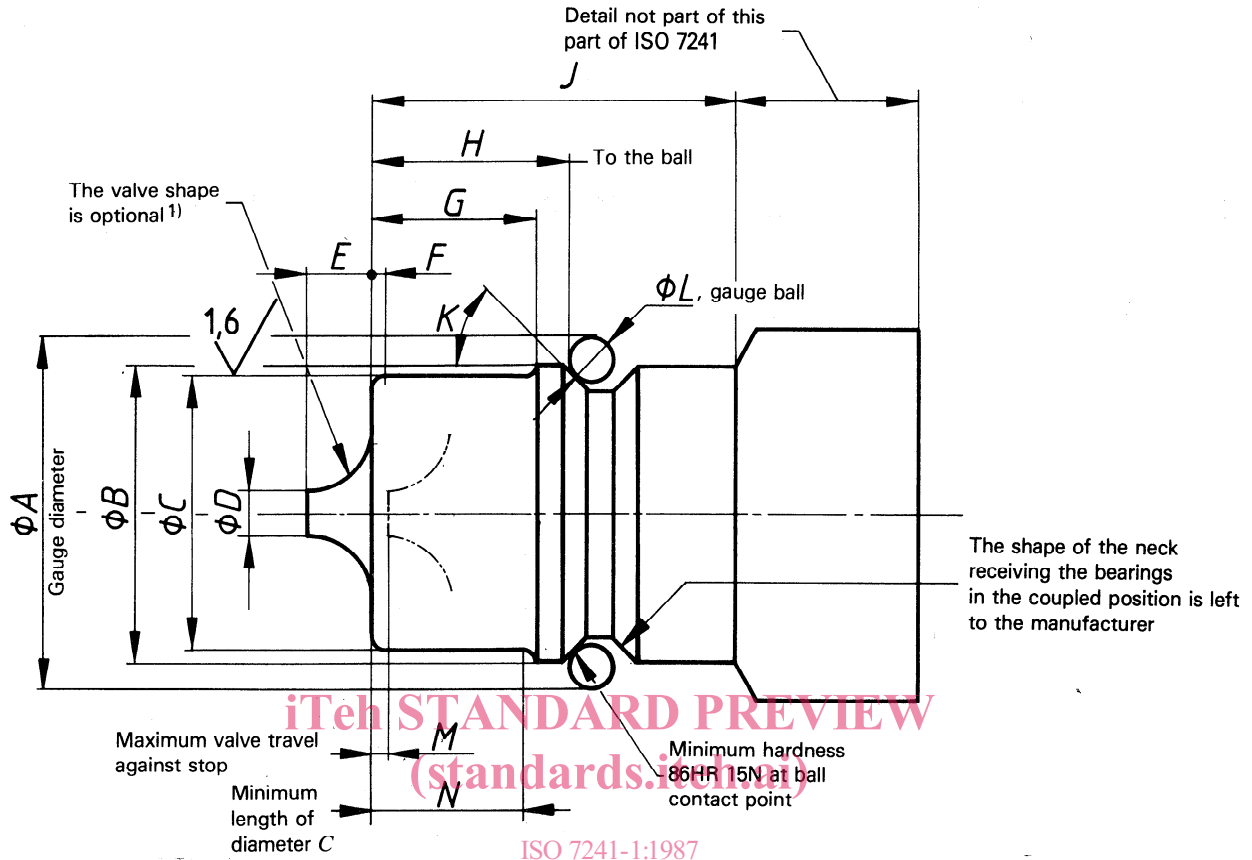

ISO 7241-1:1987
<https://standards.itech.ai/catalog/standards/sist/3b30557a-8bee-4738-afa6-e780e1788f87/iso-7241-1-1987>

Figure 1 – Dimensional requirements, series "A"

Table 1 – Dimensional requirements, series "A"

Dimensions in millimetres

Size 2)	Gauge diameter A	B	C	D min. 1)	E max.	F 3)	G	H	J min.	K	L ±0,002 5	M max.	N min.	Maximum valve open force 4)
6,3	18,7	12,9 13	11,73 11,86	1,9	1,8	0,7 1,5	5,5 5,7	6,6 6,8	14,5	44° 46°	3,968	0,5	3,7	—
10	24,1	18,3 18,4	17,2 17,3	3	3,8	0,7 1,5	8,8 9	9,9 10	18	44° 46°	3,968	0,5	7	—
12,5	30,3	23,66 23,74	20,48 20,56	4,5	4	0,7 1,5	9,2 9,4	11,6 11,8	24	44° 46°	4,762	0,5	8	45 N
20	37,1	30,4 30,5	29 29,1	5,4	7,2	1 2,5	15,9 16,1	17,5 17,7	27,5	44° 46°	4,762	0,6	13,7	—
25	43,0	36,5 36,6	34,21 34,34	7,8	8,5	1,5 3	19,7 20	22,8 23	34	44° 46°	4,762	0,7	16,3	—
31,5	56,0	47,7 47,8	44,9 45	8,9	11	2 4,5	24,9 25,1	28,4 28,6	43	44° 46°	6	0,7	24	—
40	68,5	57,5 57,6	54,9 55	9,9	13	3 6	30,6 30,8	33,7 33,9	51	44° 46°	8	0,8	29,6	—
50	83,7	69,9 70	65 65,1	9,9	16,6	3 7	35 35,2	39,6 39,8	61	44° 46°	10	0,8	34	—

- 1) Use dimension *D* except if the valve has a spherical form.
- 2) The size designation corresponds to the nominal inside diameter of the hose recommended for use with the coupling, see ISO 4397.
- 3) Radius or chamfer length. Radius with chamfer is optional.
- 4) Valve open force is the maximum force required to open fully the valve with zero internal pressure. The value for the 12,5 size is in accordance with ISO 5675 for agricultural tractors and machinery, and is the only value which has been defined up till now.

Surface roughness value in micrometres

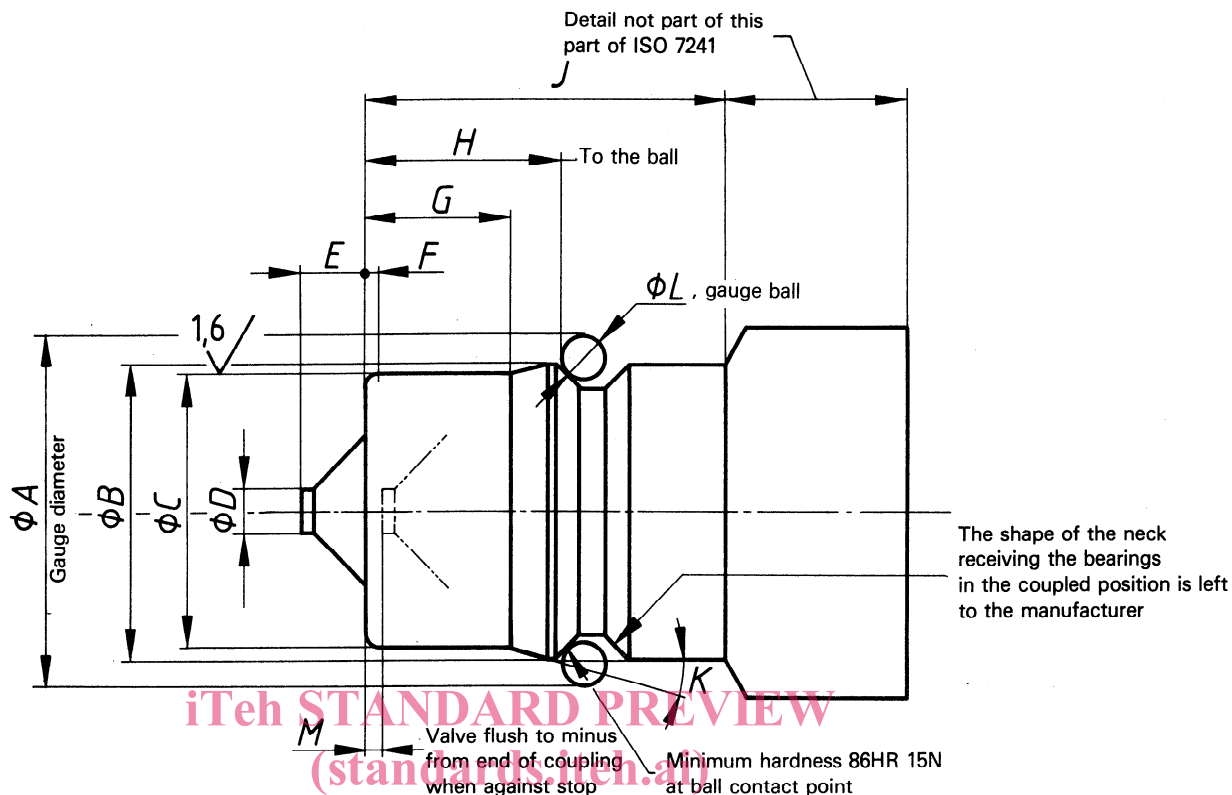

ISO 7241-1:1987
<https://standards.iteh.ai/catalog/standards/sist/3b30557a-8bee-4738-afa6-c760c1768187/iso-7241-1-1987>
 Figure 2 – Dimensional requirements, series "B" – Sizes 5 to 25

Table 2 – Dimensional requirements, series "B" – Sizes 5 to 25

Dimensions in millimetres

Size 1)	Gauge diameter A	B	C	D min.	E max.	F 2)	G min.	H	J min.	K max.	L $\pm 0,002\ 5$	M max.
5	16,69	12,09 12,19	10,8 10,9	2,16	2,79	0,64 1,32	7,87	11,28 11,48	18,92	16°	3,175	1,02
6.3	21,21	15,6 15,7	14,1 14,2	2,54	4,06	1,07 1,73	9,65	13,41 13,61	22,1	16°	3,967	1,02
10	26,87	20,04 20,14	19 19,1	3,05	4,83	1,07 1,73	12,45	15,52 15,72	24,89	16°	4,763	1,02
12.5	33,45	25,65 25,76	23,44 23,55	4,57	5,08	1,07 1,73	12,19	17,17 17,37	27,94	16°	5,555	1,02
20	41,66	32,66 32,77	31,34 31,45	5,08	7,37	1,45 2,51	18,8	22,86 23,06	35,56	16°	6,35	1,02
25	49,38	40,46 40,56	37,69 37,8	6,1	8,64	1,45 2,51	20,57	27,36 27,56	40,39	16°	6,35	1,02

- 1) The size designation corresponds to the nominal inside diameter of the hose recommended for use with the coupling, see ISO 4397.
- 2) Radius or chamfer length. Radius with chamfer is optional.

Surface roughness value in micrometres

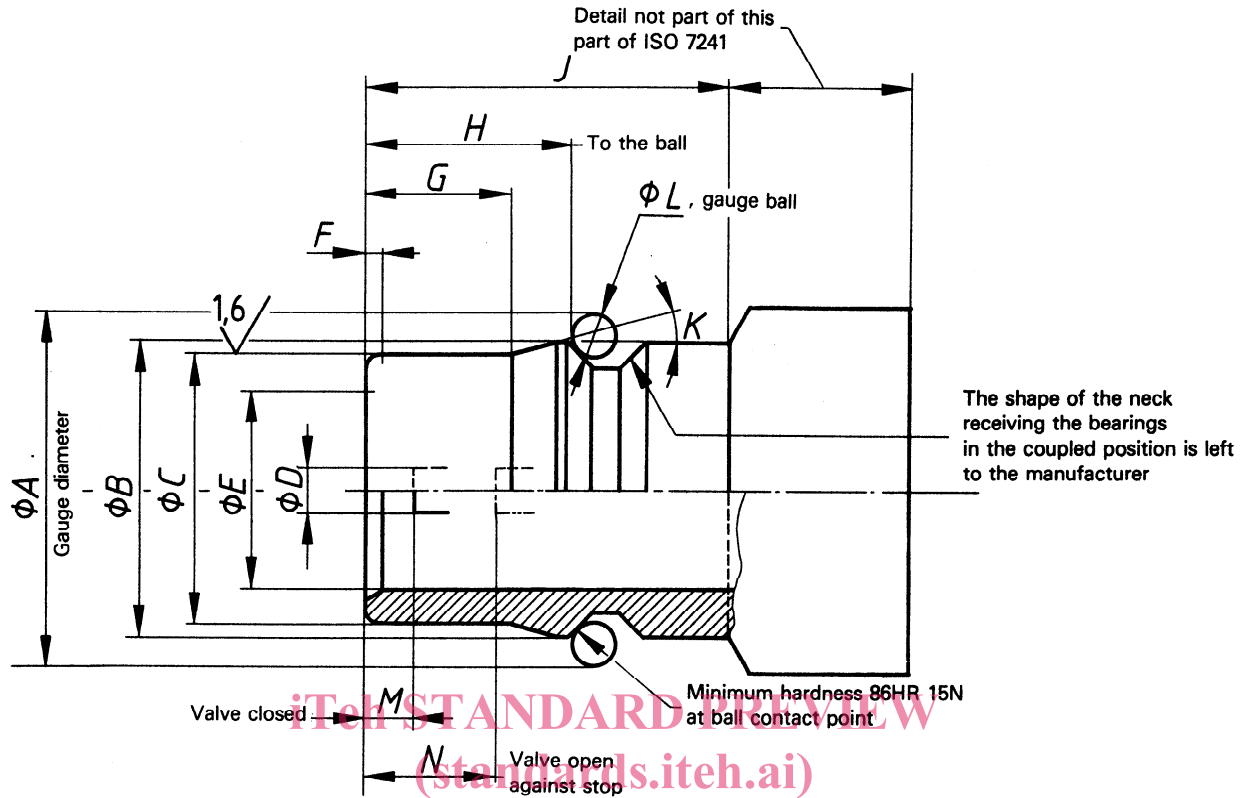

Figure 3 — Dimensional requirements, series "B" — Sizes 40 and 50

Table 3 — Dimensional requirements, series "B" — Sizes 40 and 50

Dimensions in millimetres

Size 1)	Gauge diameter A	B	C	D min.	E	F 2)	G min.	H	J min.	K max.	L ± 0,002 5	M max.	N
40	59,13	47,96 48,06	44,4 44,5	8,89	38,05 38,15	1,4 2,54	32,56	38,91 39,17	53,34	21°	7,938	10	26,36 26,87
50	85,6	66,55 66,68	63,14 63,27	10,16	53 53,16	1,4 2,54	38,1	45,16 45,42	65,02	21°	12,7	15	32 32,51

- 1) The size designation corresponds to the nominal inside diameter of the hose recommended for use with the coupling, see ISO 4397.
- 2) Radius or chamfer length. Radius with chamfer is optional.

Table 4 — Pressure rating ¹⁾

Coupling size ²⁾	Series "A"		Series "B"	
	Maximum operating pressure ³⁾ bar (MPa) ⁴⁾	Minimum burst pressure ⁵⁾ bar (MPa)	Maximum operating pressure bar (MPa)	Minimum burst pressure bar (MPa)
5	— ⁶⁾	— ⁶⁾	250 (25)	1 000 (100)
6,3	315 (31,5)	1 260 (126)	250 (25)	1 000 (100)
10	315 (31,5)	1 260 (126)	250 (25)	1 000 (100)
12,5	250 (25)	1 000 (100)	250 (25)	1 000 (100)
20	250 (25)	1 000 (100)	160 (16)	640 (64)
25	200 (20)	800 (80)	100 (10)	400 (40)
31,5	200 (20)	800 (80)	— ⁶⁾	— ⁶⁾
40	160 (16)	640 (64)	63 (6,3)	250 (25)
50	100 (10)	400 (40)	50 (5)	200 (20)

1) See ISO 2944.

2) The size designation corresponds to the nominal inside diameter of the hose recommended for use with the coupling, see ISO 4397.

3) Verify maximum operating pressure by pressure impulse testing in accordance with ISO 7241-2 for 100 000 cycles.

4) 1 bar = 100 kPa = 10⁵ Pa = 0,1 MPa; 1 Pa = 1 N/m²

5) Verify minimum burst pressure by burst pressure testing in accordance with ISO 7241-2 in the coupled and uncoupled conditions.

6) Not included in this range.

iTeh STANDARD PREVIEW (standards.iteh.ai)

Table 5 — Recommended maximum internal pressure for connecting by hand ¹⁾

ISO 7241-1:1987

Coupling size ²⁾	Series "A"	Series "B"
	Internal pressure bar (kPa)	Internal pressure bar (kPa)
5	— ³⁾	10 (1 000)
6,3	10 (1 000)	10 (1 000)
10	10 (1 000)	6,3 (630)
12,5	6,3 (630)	5 (500)
20	3,15 (315)	2,5 (250)
25	2,5 (250)	2 (200)
31,5	1,25 (125)	— ³⁾
40	0,63 (63)	1,25 (125)
50	0,5 (50)	0,5 (50)

1) See ISO 2944.

2) The size designation corresponds to the nominal inside diameter of the hose recommended for use with the coupling, see ISO 4397.

3) Not included in this range.

iTeh STANDARD PREVIEW
(standards.iteh.ai)

[ISO 7241-1:1987](https://standards.iteh.ai/catalog/standards/sist/3b30557a-8bee-4738-afa6-e780e1788f87/iso-7241-1-1987)

<https://standards.iteh.ai/catalog/standards/sist/3b30557a-8bee-4738-afa6-e780e1788f87/iso-7241-1-1987>

UDC 621.643.415

Descriptors : hydraulic fluid power, hydraulic equipment, quick action couplings, specifications, dimensions.

Price based on 5 pages
