



Designation: C 1351M – 96 (Reapproved 2002)

METRIC

Standard Test Method for Measurement of Viscosity of Glass Between 10^4 Pa·s and 10^8 Pa·s by Viscous Compression of a Solid Right Cylinder [Metric]¹

This standard is issued under the fixed designation C 1351M; the number immediately following the designation indicates the year of original adoption or, in the case of revision, the year of last revision. A number in parentheses indicates the year of last reapproval. A superscript epsilon (ϵ) indicates an editorial change since the last revision or reapproval.

1. Scope

1.1 This test method covers the determination of the viscosity of glass from 10^4 Pa·s to 10^8 Pa·s by measuring the rate of viscous compression of a small, solid cylinder.²

1.2 The values stated in SI units are to be regarded as the standard.

1.3 *This standard does not purport to address all of the safety concerns, if any, associated with its use. It is the responsibility of the user of this standard to establish appropriate safety and health practices and determine the applicability of regulatory limitations prior to use.*

2. Referenced Documents

2.1 ASTM Standards:

C 338 Test Method for the Softening Point of Glass³

C 965 Practice for Measuring Viscosity of Glass Above the Softening Point³

C 1350M Test Method for Measurement of Viscosity of Glass between the Softening Point and the Annealing Range (Approximately 10^8 Pa·s to 10^{13} Pa·s) by Beam Bending³

3. Terminology

3.1 *parallel plate viscometer*—a device used to determine the viscosity of glass from approximately 10^4 Pa·s to 10^8 Pa·s by measuring the rate of change in thickness of a cylindrical specimen between parallel plates moving perpendicular to their common central axis. The equation for calculating viscosity by the parallel plate method is:

$$\eta = 2\pi \frac{Mgh^5}{30V(dh/dt)(2\pi h^3 + V)(1 + \alpha T)} \quad (1)$$

¹ This test method is under the jurisdiction of ASTM Committee C14 on Glass and Glass Products and is the direct responsibility of Subcommittee C14.04 on Physical and Mechanical Properties.

Current edition approved Oct. 10, 1996. Published December 1996.

² Fontana, E. H., "A Versatile Parallel-Plate Viscometer For Glass Viscosity Measurements to 1000°C," *Bulletin of the American Ceramic Society*, Vol 49, No. 6, 1970, pp. 594–597.

³ *Annual Book of ASTM Standards*, Vol 15.02.

where:

η = viscosity, Pa·s,

M = applied load, g,

g = acceleration due to gravity, 980 cm/s²,

t = time, s,

V = specimen volume, cm³,

h = specimen thickness at time t , cm,

dh/dt = compression rate, cm/s, and

α = glass mean coefficient of thermal expansion, 25°C to the measurement temperature, T , m/m/°C. See Note 1.

NOTE 1—The term $(1 + \alpha T)$ corrects for the specimen dimensional changes due to thermal expansion. For low thermal expansion glasses, it can be ignored. However, for a glass with an α of $20 \times 10^{-6}/^\circ\text{C}$ at a measurement temperature of 1000°C, this term produces a correction of 2%. Only an estimate of α is necessary since the correction is small. Use twice the room temperature coefficient if data are unavailable.

4. Significance and Use

4.1 This test method is well suited for measuring the viscosity of glasses between the range within which rotational viscometry (see Practice C 965) is useful and the range within which beam bending viscometry is useful (see Test Method C 1350M). It can be used to determine the viscosity/temperature curve in the region near the softening point (see Test Method C 338). This test method is useful for providing information related to the behavior of glass as it is formed into an object of commerce, and in research and development.

5. Apparatus

5.1 The apparatus shall consist of a furnace, a means of controlling and measuring its temperature and heating rate, specimen holders and loading rod, and a means of measuring the rate of viscous compression of the glass specimen.

5.2 Furnace:

5.2.1 The furnace shall be electrically heated by resistance elements. The dimensions and details of the furnace construction are not critical; its cross-section can be circular of 75 mm (≈ 3 in.) diameter or square of sides of 75 mm. The furnace should have a constant temperature zone that covers the

specimen geometry, including the compression range. Differences in temperature greater than 2°C within the constant temperature zone are unacceptable.

5.3 Temperature Measuring and Indicating Instruments:

5.3.1 For the measurement of temperature, there shall be provided a calibrated Type K, R, or S thermocouple. The thermocouple shall be housed in a double-bore alumina tube with its junction placed within 5 mm of the specimen near the axis of the furnace. The thermocouple shall be referenced to 0°C by means of an ice bath, and its emf measured with a calibrated potentiometer that can be read with a sensitivity equivalent to $\pm 0.1^\circ\text{C}$ and an accuracy of $\pm 0.5^\circ\text{C}$. Precautions shall be taken to ensure that the ice bath is maintained at 0°C throughout the test. Alternately, the output of the thermocouple can be measured on a calibrated, direct reading meter (electronic thermometer) that can be read with a sensitivity of $\pm 0.1^\circ\text{C}$ and an accuracy of $\pm 0.5^\circ\text{C}$. See Note 3 for temperature lag-lead corrections.

5.4 Furnace Control:

5.4.1 Suitable means shall be provided for maintaining the furnace at a fixed control point and for controlling the heating and cooling rates. Commercially available programming equipment provides excellent control. A variable transformer with manual control is an inexpensive, but less adequate means of accomplishing the required control.

5.5 Specimen Holder and Loading Rod:

5.5.1 A typical configuration is presented in Fig. 1. Positioned horizontally on top of the support stand is a stationary plate (see Note 2), 6 mm ($\sim 1/4$ in.) thick by diameter of the support stand. A movable plate, 6 mm thick by 44 mm minimum diameter is placed parallel and concentrically above the fixed plate. (See parallel plates in Fig. 1.) Attached to the top center of the movable plate in a shrink fit configuration is a 9-mm ($\sim 3/8$ -in.) diameter centerless-ground alumina rod of length sufficient to reach approximately 150 mm (6 in.) beyond the top of the furnace or its supporting structure, or both. This assembly provides a means for loading the specimen during measurement. Bushings attached to the external frame guide the shaft with a minimum amount of friction.

NOTE 2—Alumina and vitreous silica are suitable materials for the assembly components, as are noble or low expansion metals used in pairs. The user must observe temperature limitations for these alternate materials.

5.6 Extensometer for Measuring Thickness Change:

5.6.1 The means of observing the rate of thickness change of the specimen should allow reliable reading of total change of at least 6 mm. The extensometer shall permit direct reading of 0.010 mm and estimates of 0.001 mm. Its accuracy shall be such that the error of indication will not exceed $\pm 2\%$ for any measured translation. This will limit the minimum translation that may be used in calculation. A linearly variable differential transformer (LVDT) is suitable for this purpose, as is any other device (for example, optical or capacitive), provided that length changes are reliably measured as specified.

5.7 Micrometer Calipers:

5.7.1 Micrometer calipers, which can be read to an accuracy of at least 0.01 mm are required for measuring specimen dimensions.

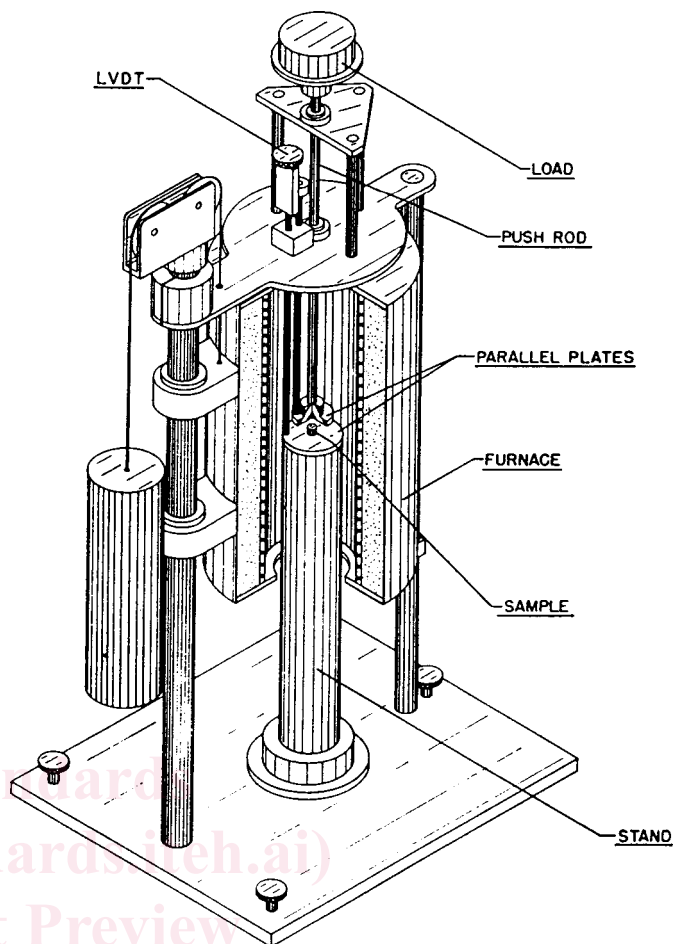

FIG. 1 A Typical Parallel Plate Viscometer

6. Preparation of Test Specimen

6.1 Specimens required for this test method are small, right, circular cylinders. Nominal dimensions are 6 mm ($\sim 1/4$ in.) to 12 mm ($\sim 1/2$ in.) diameter and 3 to 6 mm thick. Specimens can be either core-drilled from flat stock or sliced from a rod. In both cases, the flat surfaces must be ground and polished to be plane-parallel to ± 0.001 mm. Cylinders made by dry pressing of frit at high pressure can provide meaningful data.

7. Calibration

7.1 Direct calibration of the apparatus is accomplished by using standard glasses, such as those supplied and certified by the National Institute of Standards and Technology (NIST), having known viscosity/temperature values.⁴ Bias should be corrected by overall instrument calibration.

7.1.1 Determine the viscosity using test cylinders of calibrating glasses which cover a range of cross-sections expected to be used for routine testing. Determine the viscosity by following the standard procedure described in Sections 8 and 7.

⁴ Table 2, *Annual Book of ASTM Standards*, Vol 15.01, NIST Special Publication No. 260.