International Standard



7252

INTERNATIONAL ORGANIZATION FOR STANDARDIZATION • МЕЖДУНАРОДНАЯ ОРГАНИЗАЦИЯ ПО СТАНДАРТИЗАЦИИ • ORGANISATION INTERNATIONALE DE NORMALISATION

Paints and varnishes — Determination of total mercury — Flameless atomic absorption spectrometric method

Peintures et vernis — Détermination du mercure total — Méthode par spectrométrie d'absorption atomique sans flamme.

First edition — 1984-11-15

ITeH STANDARD PREVIEW
(standards.iteh.ai)

[ISO 7252:1984](https://standards.iteh.ai/catalog/standards/sist/78432976-9aae-4fb9-a69b-200fb93f9cfe/iso-7252-1984)

<https://standards.iteh.ai/catalog/standards/sist/78432976-9aae-4fb9-a69b-200fb93f9cfe/iso-7252-1984>

UDC 667.612 : 543.422 : 546.49

Ref. No. ISO 7252-1984 (E)

Descriptors : paints, varnishes, chemical analysis, determination of content, mercury, apparatus, atomic absorption method.

Foreword

ISO (the International Organization for Standardization) is a worldwide federation of national standards bodies (ISO member bodies). The work of preparing International Standards is normally carried out through ISO technical committees. Each member body interested in a subject for which a technical committee has been established has the right to be represented on that committee. International organizations, governmental and non-governmental, in liaison with ISO, also take part in the work.

Draft International Standards adopted by the technical committees are circulated to the member bodies for approval before their acceptance as International Standards by the ISO Council. They are approved in accordance with ISO procedures requiring at least 75 % approval by the member bodies voting.

International Standard ISO 7252 was prepared by Technical Committee ISO/TC 35, *Paints and varnishes*.

ITeH STANDARD PREVIEW
(standards.iteh.ai)
<https://standards.iteh.ai/catalog/standards/sist/78432976-9aae-4fb9-a69b-200fb93f9cfe/iso-7252-1984>

Paints and varnishes — Determination of total mercury — Flameless atomic absorption spectrometric method

1 Scope and field of application

This International Standard describes a flameless atomic absorption spectrometric method for the determination of the total mercury content in paints and related products.

The method is applicable to products having total mercury contents in the range of about 0,01 to 0,5 % (*m/m*).

NOTE — This method may also be applicable to products with a total mercury content of more than 0,5 % (*m/m*), provided that appropriate changes in reagent and test portion quantities are made.

2 References

ISO 385/1, *Laboratory glassware — Burettes — Part 1: General requirements*.¹⁾

ISO 648, *Laboratory glassware — One-mark pipettes*.

ISO 1042, *Laboratory glassware — One-mark volumetric flasks*.

ISO 1512, *Paints and varnishes — Sampling*.

ISO 1513, *Paints and varnishes — Examination and preparation of samples for testing*.

ISO 3696, *Water for laboratory use — Specifications*.²⁾

3 Principle

Combustion of the test portion with oxygen in an enclosed system.

Reduction of the mercury(II) compounds contained in the resulting solution to elementary mercury. Entrainment of the mercury in a current of gas at ambient temperature and determination of the mercury, as the monoatomic vapour, by cold vapour (flameless) atomic absorption spectrometry at a wavelength in the region of 253,7 nm.

4 Reagents and materials

During the analysis, use only reagents of recognized analytical grade and water of at least grade 3 purity according to ISO 3696.

4.1 Oxygen, commercial grade, in a steel cylinder.

4.2 Tin(II) chloride dihydrate, 100 g/l solution.

Dissolve 25 g of tin(II) chloride dihydrate ($\text{SnCl}_2 \cdot 2\text{H}_2\text{O}$) in 50 ml of 35 % (*m/m*) (ρ approximately 1,18 g/ml) hydrochloric acid and dilute to 250 ml with water. Add a few granules of metallic tin and heat until any precipitate disappears. Ensure that a few granules of bright tin are present to stabilize the solution and, before use, that there is no precipitate.

4.3 Sulfuric acid, 5 % (*m/m*).

4.4 Nitric acid, approximately 65 % (*m/m*) (ρ approximately 1,40 g/ml).

4.5 Mercury, standard stock solution containing 100 mg of Hg per litre.

Either

a) transfer the contents of an ampoule of a standard mercury solution containing exactly 0,1 g of Hg into a 1 000 ml one-mark volumetric flask, dilute to the mark with the sulfuric acid (4.3) and mix well;

or

b) weigh, to the nearest 0,1 mg, 0,135 4 g of mercury(II) chloride, dissolve in the sulfuric acid (4.3) in a 1 000 ml one-mark volumetric flask, dilute to the mark with the same sulfuric acid and mix well.

1 ml of this standard stock solution contains 0,1 mg of Hg.

4.6 Mercury, standard solution containing 1 mg of Hg per litre.

Prepare this solution on the day of use.

Pipette 10 ml of the standard stock solution (4.5) into a 1 000 ml one-mark volumetric flask, dilute to the mark with the sulfuric acid (4.3) and mix well.

1 ml of this standard solution contains 1 μg of Hg.

1) At present at the stage of draft. (Partial revision of ISO/R 385-1964.)

2) At present at the stage of draft.

5 Apparatus

Ordinary laboratory apparatus and

5.1 Atomic absorption spectrometer, suitable for measurements at a wavelength of 253,7 nm and capable of operating with the measuring cell specified in 5.2.

NOTE — If special commercial mercury analysers using the cold vapour AAS principle are used (see note to 7.1.2.1), appropriate amendment of the procedure described in 7.1.2 and 7.2.3 may be necessary.

5.2 Measuring cell, with windows (for example of quartz) transparent to ultraviolet radiation (in the region of 253,7 nm), the optical path length of which should be appropriate to the spectrometer being used, but not less than 100 mm.

5.3 Mercury hollow-cathode lamp or mercury discharge lamp.

5.4 Potentiometric chart recorder.

NOTE — A suitable peak measuring device such as an electronic integrator may be used as an alternative.

5.5 Combustion flask or separating funnel, of capacity 500 ml, with a ground-glass joint.

5.6 Test portion holder (platinum gauze combustion basket) and **firing adapter**, suitable for fitting to the combustion flask (5.5) (see figure 1).

5.7 Spark generator.

NOTE — A high frequency vacuum tester has been found to be satisfactory.

5.8 Flowmeter, fitted with a stainless steel needle valve and capable of measuring flow rates within the range 0,4 to 3 l/min.

5.9 Pump, diaphragm type, capable of giving controlled air flow rates of 0,4 to 3 l/min, or **cylinder of compressed air or nitrogen** equipped with a suitable pressure regulating valve.

5.10 Reaction vessel, comprising a test tube, of capacity 25 ml, with a ground glass joint neck to fit an interchangeable head and four-way stopcock (see figure 2).

5.11 Equipment, to prevent any condensation of water vapour in the measuring cell. Any appropriate system may be used for this purpose (for example an infra-red lamp, a black electrical heating element, or a rod heater).

5.12 Flexible acid-resistant tubing (for example silicon rubber tubing), suitable for connecting the apparatus (see figure 2).

5.13 Capsules, of hardened gelatine, pharmaceutical grade.

5.14 Burettes, of capacity 10 ml and 25 ml, complying with the requirements of ISO 385/1,

5.15 One-mark volumetric flasks, of capacity 25 ml and 100 ml, complying with the requirements of ISO 1042.

5.16 Pipettes, of capacity 1 ml and 5 ml, complying with the requirements of ISO 648.

5.17 Balance, capable of weighing to 0,1 mg.

6 Sampling

Take a representative sample of the product to be tested as described in ISO 1512.

Examine and prepare the sample for testing as described in ISO 1513.

7 Procedure

7.1 Preparation of the calibration graph

7.1.1 Preparation of the standard matching solutions

Prepare these solutions on the day of use.

Into a series of six 25 ml one-mark volumetric flasks (5.15), introduce from the 10 ml burette (5.14), respectively, the volumes of the standard mercury solution (4.6) shown in the following table, dilute each to the mark with the sulfuric acid (4.3), and mix well.

Standard matching solution No.	Volume of the standard mercury solution (4.6)	Corresponding concentration of Hg in the standard matching solution
	ml	µg/ml
0*	0	0
1	1	0,04
2	2	0,08
3	3	0,12
4	4	0,16
5	5	0,20

* Blank matching solution.

7.1.2 Spectrometric measurement

7.1.2.1 Install the measuring cell (5.2) and the mercury spectral source (5.3) in the spectrometer (5.1) and optimize the conditions for the determination of mercury. Adjust the instrument in accordance with the manufacturer's instructions and adjust the monochromator to the region of 253,7 nm in order to obtain the maximum absorbance. Connect the flowmeter (5.8), pump (5.9), reaction vessel (5.10), and measuring cell (5.2) with the minimum lengths of flexible tubing (5.12) as shown in figure 2.

NOTE — A closed-circuit measuring system may be used in which the mercury is recirculated by means of a pump. This will be particularly effective when the release of mercury vapour is delayed by interfering substances, e.g. bromide ions.

7.1.2.2 Switch on the pump and move the four-way stopcock to the by-pass position. Adjust the needle valve or open the gas regulating valve to give a suitable flow rate (for example 1 l/min). Set the potentiometric chart recorder (5.4) to the appropriate range. Adjust the zero of the recorder to a suitable position on the chart and check for baseline drift and noise level (see 7.1.2.4).

7.1.2.3 Disconnect the reaction vessel and, using a pipette (5.16), place 5 ml of the standard matching solution No. 5 into the vessel. Add by means of a pipette (5.16) 1 ml of the tin(II) chloride solution (4.2), mix well and immediately reconnect the reaction vessel. Reverse the four-way stopcock to allow the liberated mercury vapour to be swept through the measuring cell.

7.1.2.4 A peak will be indicated on the recorder chart and, by means of the potentiometer and flow range controls, adjust the height of the peak on the chart to about one-half the full-scale reading. Ensure that a sharp peak is obtained. Repeat if a further check of the adjustment is required.

Return the stopcock to the by-pass position and repeat the procedure using 5 ml aliquot portions of the remaining standard matching solutions.

NOTE — It may be necessary to repeat the initial test several times using the standard matching solution No. 5 in order to optimize the characteristics of the system.

7.1.3 Calibration graph

Plot a graph having the masses, in micrograms, of Hg contained in 1 ml of the standard matching solutions as abscissae and the corresponding peak heights or, more precisely, the peak areas (for example, the products of the peak height and the peak width at half the peak height), reduced by the value for the blank matching solution, as ordinates.

Over this range the curve should deviate only slightly from linearity.

NOTE — Contamination of any portion of the apparatus with aromatic solvents may give false high results owing to absorption in the region of 254 nm.

7.2 Determination

Carry out the determination in duplicate.

7.2.1 Test portion

Place approximately 20 mg of the sample under test in a tared gelatine capsule (5.13) and close immediately. Weigh the capsule and test portion to the nearest 0,1 mg.

7.2.2 Combustion

Place the weighed capsule in the test portion holder (5.6) (see figure 1). Fill the combustion flask (5.5) with the oxygen (4.1) at atmospheric pressure, quickly introduce from a 10 ml burette (5.14) 3 ml of the nitric acid (4.4) and insert the test portion holder making a gas tight seal at the ground glass joint. Attach the spark generator (5.7) to the electrical leads of the test portion holder (see figure 3), place the apparatus behind a safety screen and switch on the high voltage to activate the spark and ignite the test portion.

After combustion is complete, shake the flask and contents and allow to stand for 30 min with occasional shaking. Remove the test portion holder and add to the flask 22 ml of water from a 25 ml burette (5.14). Replace the test portion holder and shake thoroughly.

Retain the bulk of the contents of the combustion flask in a stoppered glass container of capacity approximately 25 ml.

7.2.3 Spectrometric measurement

Using a pipette (5.16), place 5 ml of the solution (7.2.2) in a 100 ml one-mark volumetric flask (5.15), dilute to the mark with the sulfuric acid (4.3), and mix well.

Using a pipette (5.16), place 5 ml of this test solution in the reaction vessel (5.10). Add by means of a pipette (5.16) 1 ml of the tin(II) chloride solution (4.2), mix well and immediately reconnect the reaction vessel. Reverse the four-way stopcock to allow the liberated mercury vapour to be swept through the measuring cell.

Record the peak reading (i.e. either peak height or peak area, see 7.1.3), reduced by the reading obtained for the blank test solution (see 7.2.4). Read off the mercury concentration from the calibration graph.

If the response of a test solution is higher than that of the standard matching solution with the highest mercury concentration (that is matching solution No. 5), dilute the test solution appropriately (dilution factor F) with a known volume of the sulfuric acid (4.3) before repeating the determination.

Calculate the mean of the duplicate readings. If the readings differ by more than 20 % of their mean, repeat the determination.

7.2.4 Blank test

Carry out a blank test immediately after the determination, following the same procedure, using a gelatine capsule (5.13) and the same quantities of all the reagents as those used in the determination, but omitting the test portion.

8 Expression of results

Dimensions in millimetres

8.1 Calculation

Calculate the total mercury content of the paint using the equation

$$c_{Hg} = \frac{a \times 25 \times F}{V \times m \times 10^2} = 0,25 \frac{a \times F}{V \times m}$$

where

a is the mercury concentration, in micrograms per millilitre, of the test solution, obtained from the calibration graph;

c_{Hg} is the total mercury content of the paint, expressed as a percentage by mass;

F is the dilution factor referred to in 7.2.3;

m is the mass, in grams, of the test portion (7.2.1);

V is the volume, in millilitres, of the solution (7.2.2) used to prepare the test solution in 7.2.3 (= 5 ml).

Calculate the mean of the two results

8.2 Precision

No precision data are currently available.

9 Test report

The test report shall contain at least the following information:

- a) the type and identification of the product tested;
- b) a reference to this International Standard (ISO 7252);
- c) the result of the test;
- d) any deviation, by agreement or otherwise, from the test procedure specified;
- e) the date of the test.

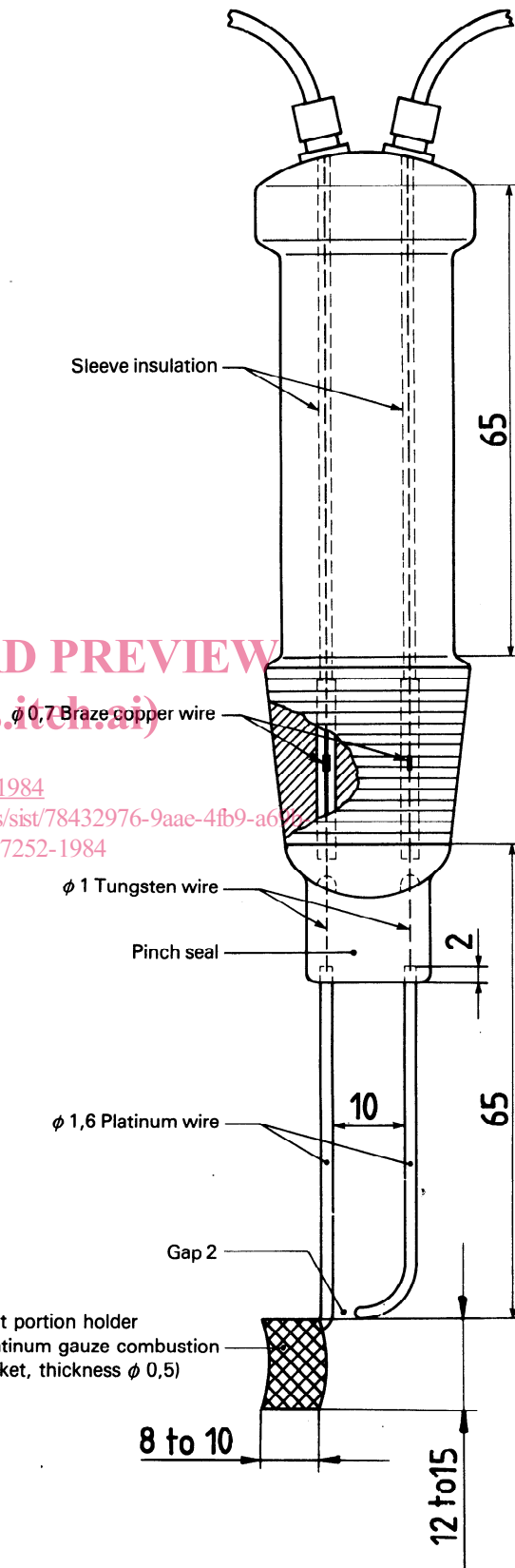

Figure 1 — Firing adapter

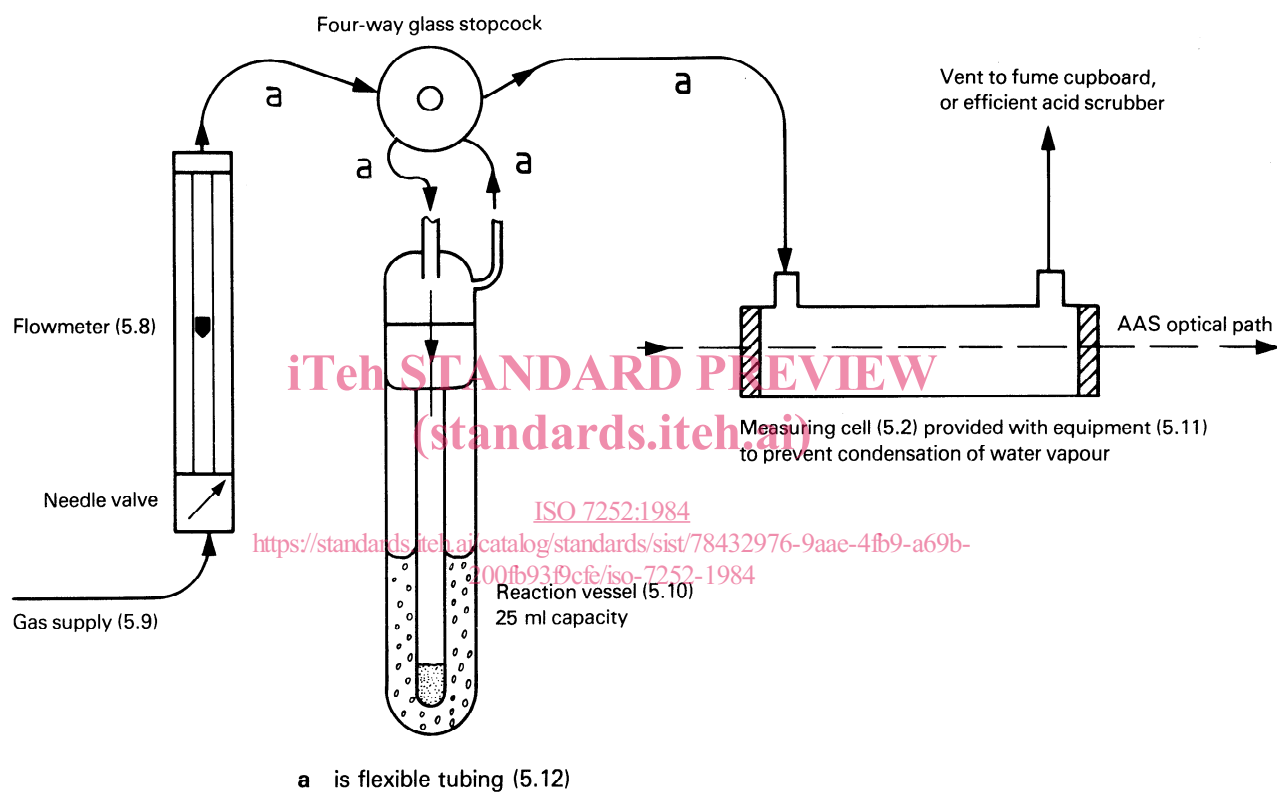
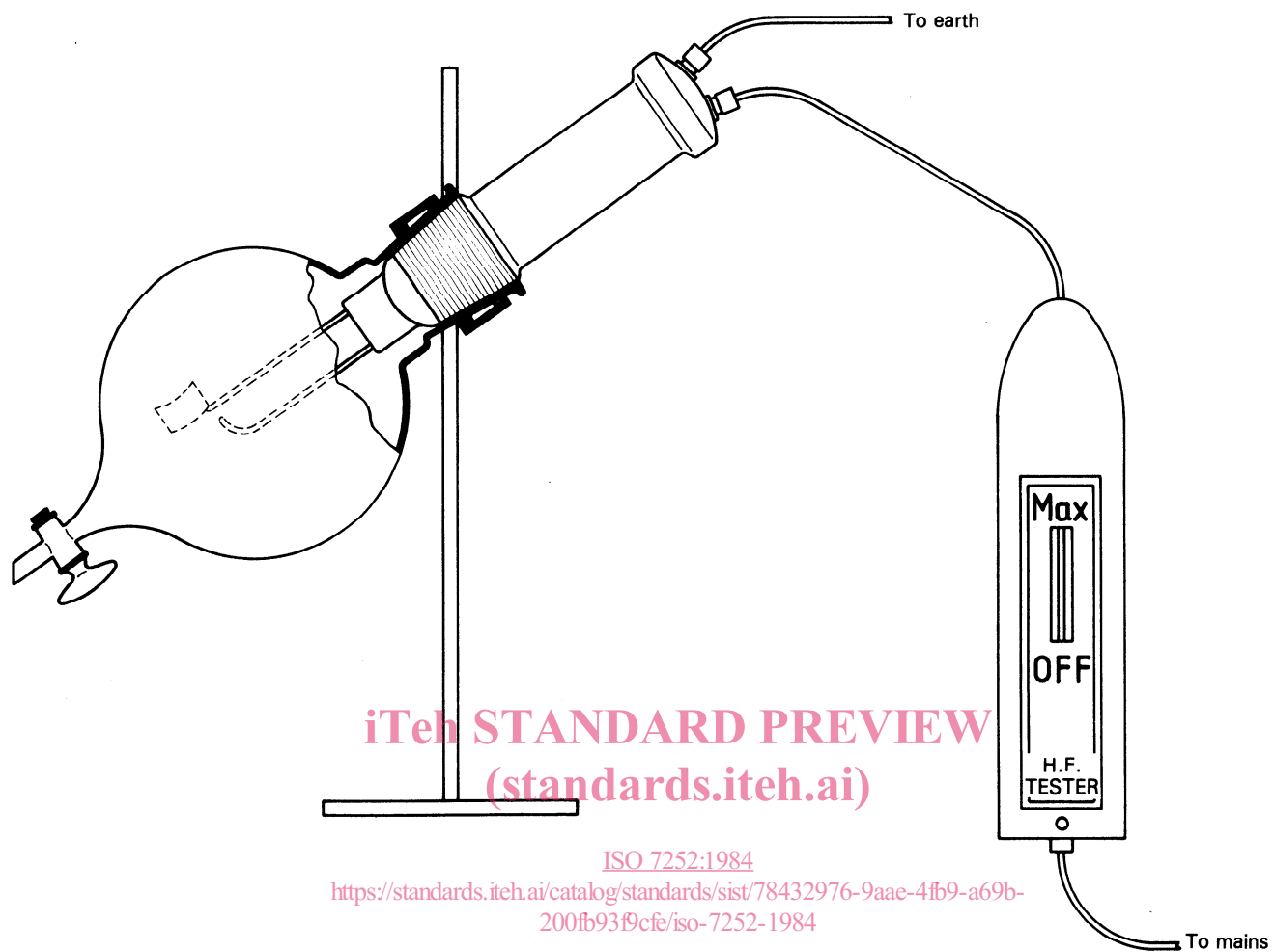

Figure 2 – Typical apparatus for the determination of mercury by flameless atomic absorption spectrometry



ISO 7252:1984
<https://standards.iteh.ai/catalog/standards/sist/78432976-9aae-4fb9-a69b-200fb93f9cfe/iso-7252-1984>

Figure 3 – General view of combustion apparatus
