International Standard



7312

INTERNATIONAL ORGANIZATION FOR STANDARDIZATION • МЕЖДУНАРОДНАЯ ОРГАНИЗАЦИЯ ПО СТАНДАРТИЗАЦИИ • ORGANISATION INTERNATIONALE DE NORMALISATION

Road vehicles — Air filter connections — Types A and B

Véhicules routiers — Raccords pour filtres à air — Types A et B

First edition — 1984-10-15

iTeh STANDARD PREVIEW
(standards.iteh.ai)

[ISO 7312:1984](https://standards.iteh.ai/catalog/standards/sist/4510d269-e411-4d03-b0e7-a64a9159e798/iso-7312-1984)

<https://standards.iteh.ai/catalog/standards/sist/4510d269-e411-4d03-b0e7-a64a9159e798/iso-7312-1984>

UDC 621.43.038.771 : 621.643.4 : 621.882

Ref. No. ISO 7312-1984 (E)

Descriptors: road vehicles, air filters, junctions, dimensions, designation.

Foreword

ISO (the International Organization for Standardization) is a worldwide federation of national standards bodies (ISO member bodies). The work of preparing International Standards is normally carried out through ISO technical committees. Each member body interested in a subject for which a technical committee has been established has the right to be represented on that committee. International organizations, governmental and non-governmental, in liaison with ISO, also take part in the work.

Draft International Standards adopted by the technical committees are circulated to the member bodies for approval before their acceptance as International Standards by the ISO Council. They are approved in accordance with ISO procedures requiring at least 75 % approval by the member bodies voting.

International Standard ISO 7312 was prepared by Technical Committee ISO/TC 22, *Road vehicles*.

ITEH STANDARD PREVIEW
(standards.iteh.ai)

<https://standards.iteh.ai/catalog/standards/sist/4510d269-e411-4d03-b0e7-a64a9159e798/iso-7312-1984>

Road vehicles — Air filter connections — Types A and B

iTeh STANDARD PREVIEW
(standards.iteh.ai)

1 Scope and field of application

This International Standard specifies the essential dimensional characteristics of air filter connections used in road vehicles.

2 Dimensions

Two types are specified:

Type A — flexible tube connector: see figure 1 and table 1.

Type B — thread connector: see figure 2 and table 2.

2.1 Connector type A

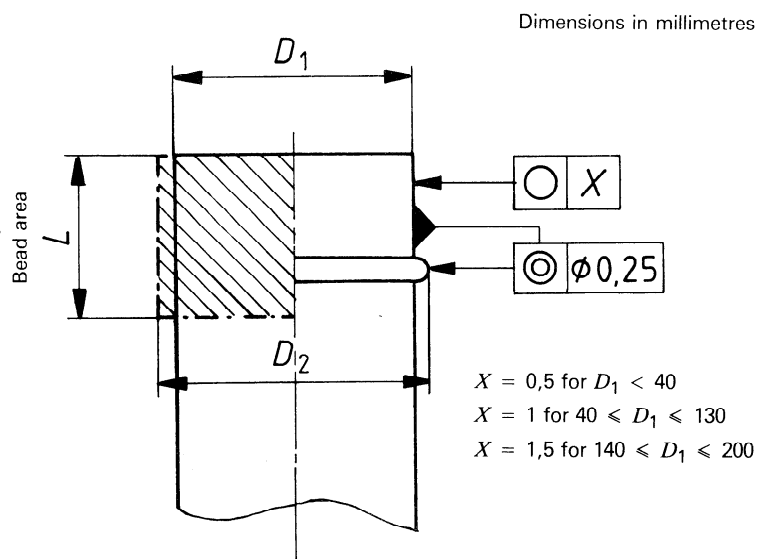

Figure 1 — Type A
 iTeh STANDARD PREVIEW
 (standards.iteh.ai)

ISO 7312:1984
 Table 1 — Type A
<https://standards.iteh.ai/catalog/standards/sist/4510d269-e411-4d03-b0e7-a64a9159e798/iso-7312-1984>
 Dimensions in millimetres

D_1		D_2		L max.	
Nominal	Tolerance	Nominal	Tolerance		
20	$\pm 0,3$	21,5	$+0,5$ 0	8	
22					
25					
28					
32					
40					
45					
50					
55					
60					
63	$\pm 0,5$	65	$+1$ 0	12	
70					
75					
80					
90					
100					
110	$\pm 0,8$	112		$+1$ 0	12
120					
130					
140					
150					
160					
180	$\pm 1,0$	182	$+1$ 0		12
200					
202					

NOTE — The shape of the bead is optional. If there is no bead D_1 applies.

2.2 Connector type B

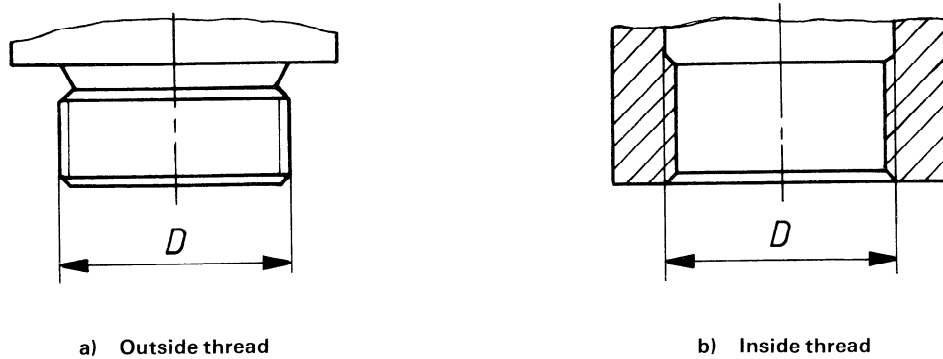

Figure 2 – Type B

Table 2 – Type B

Dimensions in millimetres

Thread <i>D</i>	
M 8 × 1	M36 × 2
M10 × 1 ¹⁾	M39 × 2
M12 × 1,5	M42 × 2
M14 × 1,5	M45 × 2
M16 × 1,5	M48 × 2
M18 × 1,5	M52 × 2
M20 × 1,5	M56 × 2
M22 × 1,5	M60 × 2
M24 × 1,5	M64 × 2
M26 × 1,5	M78 × 2
M30 × 1,5	
M33 × 1,5	

For application on "heavy devices" it is possible to use the following thread sizes:
M27 × 2 – M30 × 2 – M33 × 2

1) Used for service-devices.

3 Designation

Example for the designation of an air filter connector of type A with diameter $D_1 = 60$ mm and with bead $D_2 = 62$ mm:

Connector ISO 7312 - A 60 × 62

Example for the designation of an air filter connector of type B with $D = M20 \times 1,5$ thread:

Connector ISO 7312 - B M20 × 1,5

iTeh STANDARD PREVIEW
This page intentionally left blank
(standards.iteh.ai)

[ISO 7312:1984](#)

<https://standards.iteh.ai/catalog/standards/sist/4510d269-e41-4d03-b0e7-a64a9159e798/iso-7312-1984>

iTeh STANDARD PREVIEW
This page intentionally left blank
(standards.iteh.ai)

[ISO 7312:1984](#)

<https://standards.iteh.ai/catalog/standards/sist/4510d269-e41-4d03-b0e7-a64a9159e798/iso-7312-1984>

iTeh STANDARD PREVIEW
This page intentionally left blank
(standards.iteh.ai)

[ISO 7312:1984](#)

<https://standards.iteh.ai/catalog/standards/sist/4510d269-e411-4d03-b0e7-a64a9159e798/iso-7312-1984>