

INTERNATIONAL STANDARD

ISO
7315

Second edition
1988-02-01



INTERNATIONAL ORGANIZATION FOR STANDARDIZATION
ORGANISATION INTERNATIONALE DE NORMALISATION
МЕЖДУНАРОДНАЯ ОРГАНИЗАЦИЯ ПО СТАНДАРТИЗАЦИИ

Aerospace — “P” clamps (loop clamps) for fluid systems — Envelope dimensions

*Aéronautique et espace —
d'encombrement*

ITC STANDARD PREVIEW

(standards.iteh.ai)

ISO 7315:1988

<https://standards.iteh.ai/catalog/standards/sist/2a9a0b47-379d-452b-b591-6826d685bbc9/iso-7315-1988>

Reference number
ISO 7315:1988 (E)

Foreword

ISO (the International Organization for Standardization) is a worldwide federation of national standards bodies (ISO member bodies). The work of preparing International Standards is normally carried out through ISO technical committees. Each member body interested in a subject for which a technical committee has been established has the right to be represented on that committee. International organizations, governmental and non-governmental, in liaison with ISO, also take part in the work.

Draft International Standards adopted by the technical committees are circulated to the member bodies for approval before their acceptance as International Standards by the ISO Council. They are approved in accordance with ISO procedures requiring at least 75 % approval by the member bodies voting.

International Standard ISO 7315 was prepared by Technical Committee ISO/TC 20, *Aircraft and space vehicles*.

This second edition cancels and replaces the first edition (ISO 7315:1985), of which table 2 has been revised (addition of DN 36 and DN 45 to DN 100).

Users should note that all International Standards undergo revision from time to time and that any reference made herein to any other International Standard implies its latest edition, unless otherwise stated.

Aerospace — “P” clamps (loop clamps) for fluid systems — Envelope dimensions

iTeh STANDARD PREVIEW (standards.iteh.ai)

1 Scope

This International Standard specifies maximum and minimum dimensions for “P” clamps (loop clamps) installed by means of a bolt with a nominal diameter of 5 mm.

The specified dimensions define a dimensional envelope. This International Standard shall not be considered as an interchangeability standard. The tolerances for each type of clamp are to be defined in the parts standards drawings.

2 Field of application

These clamps are intended for the installation, support and guiding of rigid tubing or hose assemblies used in aerospace equipment.

NOTE — “P” clamps (loop clamps) may also be used for other equipment, e.g. electrical cables or looms.

3 Reference

ISO 6771, *Aerospace — Fluid systems and components — Pressure and temperature classifications.*

4 Classification

“P” clamps (loop clamps) are classified into six types according to the temperature range in which they are intended to be used (see table 1).

Table 1

Temperatures in degrees Celsius

Clamp type	Temperature range ¹⁾	
	min.	max.
1	– 55	+ 70
2	– 55	+ 135
3	– 55	+ 200
4	– 55	+ 320
5	– 55	+ 400
6	– 55	+ 650

1) See ISO 6771.

5 Description

The “P” clamp (loop clamp) is a “single-block” or a “multi-component”-type clamp. The “multi-component”-type clamp is provided as a metallic support with a plastomer or elastomer cushion or sheathing.

6 Dimensions

The “P” clamp (loop clamp) shall be in accordance with the figure and table 2.

The shape of clamp illustrated in the figure does not purport to be the exact shape of the manufactured clamp. Table 2 only specifies those dimensions required to define the maximum envelope and the proper location of the tube relative to the mounting plane and fastening point.

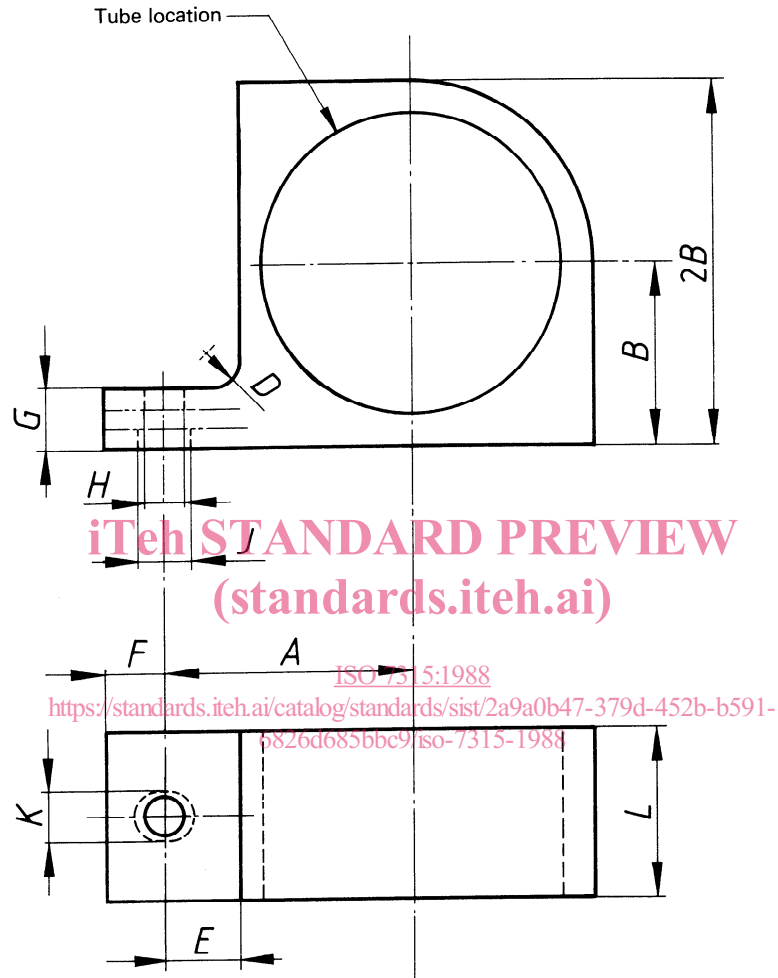

Figure — Maximum envelope dimensions for "P" clamps (loop clamps)

Table 2 ¹⁾

Dimensions in millimetres

Nominal diameter of tube DN ²⁾	A		B ³⁾		D	E	F	G	H		J	K	L ³⁾
	min.	max.	min.	max.	max.	min.	max.	max.	min.	max.	max.	+0,3 0	max.
04	11	12,7	2,8	6,0	2,5	8,1	5,5	8	5,2	5,5	6,5	5,2	19
05	11,5	13,2	3,2	6,5	2,5	8,1	5,5	8	5,2	5,5	6,5	5,2	19
06	12	13,7	3,8	7,0	2,5	8,1	5,5	8	5,2	5,5	6,5	5,2	19
08	13	14,7	4,8	8,0	2,5	8,1	5,5	8	5,2	5,5	6,5	5,2	19
10	14	15,7	5,8	9,0	2,5	8,1	5,5	8	5,2	5,5	6,5	5,2	19
12	15	16,7	6,8	10	2,5	8,1	5,5	8	5,2	5,5	6,5	5,2	19
14	17,5	19,1	7,8	11,2	3,3	8,8	5,5	8	5,2	5,5	6,5	5,2	19
16	18,5	20,1	8,8	12,3	3,3	8,8	5,5	8	5,2	5,5	6,5	5,2	19
18	19,5	21,1	9,8	13,3	3,3	8,8	5,5	8	5,2	5,5	6,5	5,2	19
20	20,5	22,1	10,8	14,3	3,3	8,8	5,5	8	5,2	5,5	6,5	5,2	19
22	21,5	23,1	11,8	15,3	3,3	8,8	5,5	8	5,2	5,5	6,5	5,2	19
25	23	24,6	13,3	16,8	3,3	8,8	5,5	8	5,2	5,5	6,5	5,2	19
28	24,5	26,8	14,8	19,4	4	9,1	5,5	8	5,2	5,5	6,5	5,2	19
32	26,5	28,8	16,8	20,7	4	9,1	5,5	8	5,2	5,5	6,5	5,2	19
36	28,5	30,8	18,8	21,7	4	9,1	5,5	8	5,2	5,5	6,5	5,2	19
40	30,5	32,8	20,8	24,7	4	9,1	5,5	8	5,2	5,5	6,5	5,2	19
45	33	35,5	23	27,3	4	9,1	5,5	8	5,2	5,5	6,5	5,2	19
50	35,5	38	25,5	29,8	4	9,1	5,5	8	5,2	5,5	6,5	5,2	19
56	38,5	41	28,5	32,8	4	9,1	5,5	8	5,2	5,5	6,5	5,2	19
63	42	44,5	32	36,3	4	9,1	5,5	8	5,2	5,5	6,5	5,2	19
70	45,5	48	35,5	39,8	4	9,1	5,5	8	5,2	5,5	6,5	5,2	19
80	50,5	53	40,5	44,8	4	9,1	5,5	8	5,2	5,5	6,5	5,2	19
90	55,5	58	45,5	49,8	4	9,1	5,5	8	5,2	5,5	6,5	5,2	19
100	60,5	63	50,5	54,8	4	9,1	5,5	8	5,2	5,5	6,5	5,2	19

- 1) All dimensions in this table apply with the tube assembled in the tightened clamp.
- 2) Diameters DN 14, 18, 22, 28, 36, 45, 56, 70 and 90 are non-preferred sizes for tubing in fluid systems.
- 3) This dimension is an overall dimension which includes metal width and cushion or sheathing.

iTeh STANDARD PREVIEW
(standards.iteh.ai)

This page intentionally left blank

[ISO 7315:1988](#)

<https://standards.iteh.ai/catalog/standards/sist/2a9a0b47-379d-452b-b591-6826d685bbc9/iso-7315-1988>

iTeh STANDARD PREVIEW
(standards.iteh.ai)

This page intentionally left blank

ISO 7315:1988

<https://standards.iteh.ai/catalog/standards/sist/2a9a0b47-379d-452b-b591-6826d685bbc9/iso-7315-1988>

iTeh STANDARD PREVIEW
(standards.iteh.ai)

ISO 7315:1988

<https://standards.iteh.ai/catalog/standards/sist/2a9a0b47-379d-452b-b591-6826d685bbc9/iso-7315-1988>

UDC 621.643.45 : 629.7

Descriptors : aircraft, aircraft equipment, fluid circuits, fluid pipelines, pipe supports, pipe clips, dimensions.

Price based on 3 pages
