



# SLOVENSKI STANDARD

## SIST ENV 12834:2003

01-oktober-2003

---

### Cestna transportna in prometna telematika (RTTT) – Posebna komunikacija kratkega dosega (DSRC) – Aplikacijska plast

Road Transport and Traffic Telematics (RTTT) - Dedicated Short-Range Communication (DSRC) - Application Layer

Telematik für Transport und Straßenverkehr - Dedizierte Nahbereichskommunikation - Anwendungsebene

**iTeh STANDARD PREVIEW**  
**(standards.iteh.ai)**

Télématique du Transport Routier et de la Circulation - Communication Dédiée, a Courte Portée - Couche Application

[SIST ENV 12834:2003](https://standards.iteh.ai/catalog/standards/sist/c7a9e6e2-1d3a-4c73-9628-f2a5c3001929/sist-env-12834-2003)

[https://standards.iteh.ai/catalog/standards/sist/c7a9e6e2-1d3a-4c73-9628-](https://standards.iteh.ai/catalog/standards/sist/c7a9e6e2-1d3a-4c73-9628-f2a5c3001929/sist-env-12834-2003)

[f2a5c3001929/sist-env-12834-2003](https://standards.iteh.ai/catalog/standards/sist/c7a9e6e2-1d3a-4c73-9628-f2a5c3001929/sist-env-12834-2003)

**Ta slovenski standard je istoveten z: ENV 12834:1997**

---

#### **ICS:**

35.100.70	Uporabniški sloj	Application layer
35.240.60	Uporabniške rešitve IT v transportu in trgovini	IT applications in transport and trade

**SIST ENV 12834:2003**

**en**

**iTeh STANDARD PREVIEW**  
**(standards.iteh.ai)**

SIST ENV 12834:2003

<https://standards.iteh.ai/catalog/standards/sist/c7a9e6e2-1d3a-4c73-9628-f2a5c3001929/sist-env-12834-2003>

EUROPEAN PRESTANDARD  
 PRÉNORME EUROPÉENNE  
 EUROPÄISCHE VORNORM

**ENV 12834**

November 1997

ICS 35.100.70; 35.240.60

Descriptors: teleprocessing, traffic, road transport, information interchange, data transmission, open systems  
 interconnection, application layers

English version

## Road Transport and Traffic Telematics (RTTT) - Dedicated Short-Range Communication (DSRC) - Application Layer

Télématique du Transport Routier et de la Circulation -  
 Communication Dédinée, à Courte Portée - Couche  
 Application

Telematik für Transport und Straßenverkehr - Dedizierte  
 Nahbereichskommunikation - Anwendungsebene

This European Prestandard (ENV) was approved by CEN on 10 October 1997 as a prospective standard for provisional application.

The period of validity of this ENV is limited initially to three years. After two years the members of CEN will be requested to submit their comments, particularly on the question whether the ENV can be converted into a European Standard.

CEN members are required to announce the existence of this ENV in the same way as for an EN and to make the ENV available promptly at national level in an appropriate form. It is permissible to keep conflicting national standards in force (in parallel to the ENV) until the final decision about the possible conversion of the ENV into an EN is reached.

CEN members are the national standards bodies of Austria, Belgium, Czech Republic, Denmark, Finland, France, Germany, Greece, Iceland, Ireland, Italy, Luxembourg, Netherlands, Norway, Portugal, Spain, Sweden, Switzerland and United Kingdom.

<https://standards.iteh.ai/catalog/standards/sist/c7a9e6e2-1d3a-4c73-9628-f2a5c3001929/sist-env-12834-2003>



EUROPEAN COMMITTEE FOR STANDARDIZATION  
 COMITÉ EUROPÉEN DE NORMALISATION  
 EUROPÄISCHES KOMITEE FÜR NORMUNG

Central Secretariat: rue de Stassart, 36 B-1050 Brussels

## CONTENTS LIST

<b>INTRODUCTION</b> .....	4
<b>1 SCOPE</b> .....	5
<b>2 NORMATIVE REFERENCES</b> .....	7
<b>3 DEFINITIONS</b> .....	8
3.1 ARCHITECTURE .....	8
3.2 COMMUNICATION .....	10
3.3 FUNCTIONALITIES.....	11
3.4 CHARACTERISTICS OF ELEMENTS .....	12
<b>4 ABBREVIATIONS</b> .....	15
<b>5 APPLICATION LAYER ARCHITECTURE</b> .....	17
5.1 STRUCTURE.....	17
5.2 SERVICE CLASSES .....	17
5.3 CONTROL OF ACCESS TO INFORMATION .....	17
<b>6 KERNEL ELEMENTS</b> .....	18
6.1 GENERAL .....	18
6.2 TRANSFER-KE (TRANSFER-SERVICE-PROVIDER).....	18
6.3 INITIALISATION-KE (INITIALISATION-SERVICE-PROVIDER) .....	31
6.4 BROADCAST-KE (BROADCAST-SERVICE-PROVIDER).....	39
<b>7 MANAGEMENT</b> .....	42
7.1 SCOPE.....	42
7.2 PROFILES.....	42
<b>ANNEX A: DATA STRUCTURES (NORMATIVE)</b> .....	45
A 1 USE OF MODULES .....	45
A 2 ASN.1-MODULES.....	46
<b>ANNEX B: NAMING AND REGISTRATION (NORMATIVE)</b> .....	57
B.1 REGISTRATION AUTHORITY AND PROCEDURE.....	57
B.2 ITEMS FOR REGISTRATION .....	58
B.3 ITEMS DEFINED BY THE APPLICATIONS.....	59
<b>ANNEX C: GENERAL NOTES ON THE IMPLEMENTATION (INFORMATIVE)</b> .....	60
C.1 CHARACTER OF AN ENABLING STANDARD.....	60



**ANNEX D: EXAMPLES (INFORMATIVE)** ..... 62

D.1 HOW TO REALIZE VERY SIMPLE APPLICATIONS ..... 62

D.2 HOW TO TRANSFER A BIT STRING ..... 63

D.3 RELATION SECURITY AND ENCODING/DECODING ..... 64

**iTeh STANDARD PREVIEW**  
**(standards.iteh.ai)**

SIST ENV 12834:2003

<https://standards.iteh.ai/catalog/standards/sist/c7a9e6e2-1d3a-4c73-9628-f2a5c3001929/sist-env-12834-2003>

## FOREWORD

This European Prestandard has been prepared by Technical Committee CEN/TC 278 "Road transport and traffic telematics", the secretariat of which is held by NNI.

According to the CEN/CENELEC Internal Regulations, the national standards organizations of the following countries are bound to announce this European Prestandard: Austria, Belgium, Czech Republic, Denmark, Finland, France, Germany, Greece, Iceland, Ireland, Italy, Luxembourg, Netherlands, Norway, Portugal, Spain, Sweden, Switzerland and the United Kingdom.

## INTRODUCTION

The communication requirements of many Road Transport and Traffic Telematics (RTTT) applications can be fulfilled by Dedicated Short-Range Communication (DSRC). The small service areas and severe real-time constraints require a specific protocol architecture leading to the reduced protocol stack shown in figure 1, built up by the application layer, the data link layer, and the physical layer. Such an architecture is very common for real-time environments. The DSRC protocol stack is set up in accordance with the master-slave principle, where the beacon as the master organises the entire communication process. The DSRC Standards enable compliant communication systems to serve multiple RTTT applications in parallel.

SIST ENV 12834:2003

<https://standards.iteh.ai/catalog/standards/sist/c7a9c6c2-1d3a-4c73-9628->

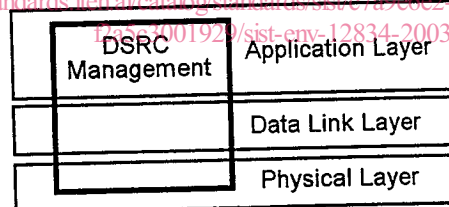

*figure 1: DSRC protocol stack*

This European Standard gives the architecture and services offered by the DSRC Application Layer. The Standard defines the Application Service Elements (ASE). These element definitions consists of Application Protocol Data Units (APDU), Application Service Data Units (ASDU) and actions on these ASDUs. Actions on ASDUs are performed by invocation of the Service Primitives (SP).

The application layer architecture allows for RTTT applications to choose the suitable elements ranging from simple services up to complex services, accommodating multiple parallel applications.

## 1 SCOPE

This Standard is applicable to the Application Layer of the Dedicated Short-Range Communication (DSRC) system. Figure 2 illustrates the global data flow between the elements of the DSRC system, (Physical, Data Link and Application Layer) and the application.

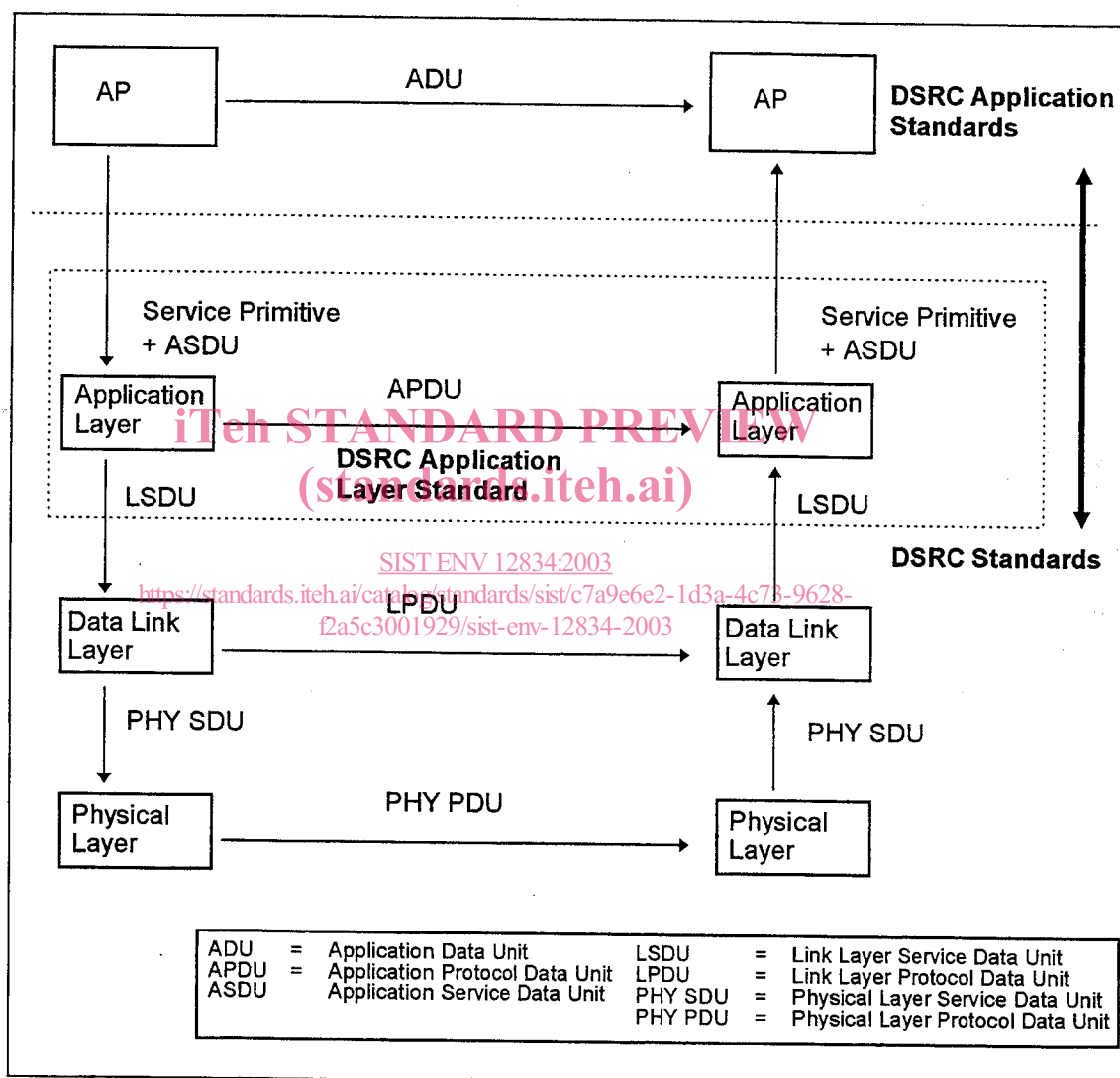

figure 2: Global data flow between communication system and application

The purpose of the Application Layer is to provide communication tools for the application, whilst the scope of the application oriented working groups is to build the application using amongst others the tools provided by Application Layer. These tools consist of elements which can be used by application processes. This approach allows the re-use of the application processes in other communication environments i.e. using other bearers.

The following subjects are covered by this Standard:

- Application Layer structure and framework,
- Services to enable data transfer and remote operations,
- Application multiplexing procedure,
- Fragmentation procedure,
- Concatenation procedure,
- Common encoding rules to translate data in local syntax with an abstract syntax defined by ASN.1 into transfer syntax and vice versa,
- Communication negotiation and initialisation procedure,
- Broadcast service support,
- Facilities for association control,
- DSRC management support including communication profile handling

## **iTeh STANDARD PREVIEW** **(standards.iteh.ai)**

[SIST ENV 12834:2003](#)

<https://standards.iteh.ai/catalog/standards/sist/c7a9e6e2-1d3a-4c73-9628-f2a5c3001929/sist-env-12834-2003>



## 2 NORMATIVE REFERENCES

This Standard incorporates by dated or undated reference, provisions from other publications. These normative references are cited at the appropriate places in the text and the publications listed hereafter. For dated references, subsequent amendments to or revisions of any of these publications apply to this Standard only when incorporated in it by amendment or revision. For undated references the latest edition of the publication referred to applies.

- ISO 8824-1 1995 Information technology - Abstract Syntax Notation One (ASN.1): Specification of basic notation
- ISO 8825-2 1994 Information technology - Open Systems Interconnection - Specification of Basic Encoding Rules for Abstract Syntax Notation One (ASN.1), Part 2: Packed encoding rules
- ISO 9595 1991 Information technology - Open Systems Interconnection - Common management information service definition. With technical corrigenda 1 & 2.
- ISO/IEC 7498-1 1994 Information technology - Open Systems Interconnection - Basic Reference Model: The Basic Model
- ENV 12795 Road Traffic and Transport Telematics (RTTT) - Dedicated Short-Range Communication (DSRC) - DSRC Data Link Layer: Medium Access and Logical Link Control

<https://standards.iteh.ai/catalog/standards/sist/c7a9e6e2-1d3a-4c73-9628-f2a5c3001929/sist-env-12834-2003>

## 3 DEFINITIONS

### 3.1 ARCHITECTURE

#### 3.1.1 APPLICATION ENTITY

The aspect of an application process pertinent to DSRC.

#### 3.1.2 APPLICATION LAYER

The Application Layer provides services that enable application data transfer and remote application related operations. It defines the transfer syntax over the air interface and communication procedures for application multiplexing, fragmentation and concatenation. It also supports DSRC management including communication profile handling, through the defined communication negotiation and initialisation procedure.

#### 3.1.3 APPLICATION LAYER KERNEL

The Application Layer Kernel provides the minimum set of services realized by the Kernel Elements (KE) needed to support several RTTT applications in parallel. This requires the means for dialogue initiation, offered by the Initialisation-KE, cyclic broadcast transmission, offered by the Broadcast pool-KE, and a generic transfer of DSRC data structures, offered by the Transfer-KE. The Application Layer Kernel Elements always exist as single instances and are allocated outside the Application Processes, whereas several instances of these elements which access the kernel may exist in the Application Processes.

#### 3.1.4 APPLICATION LAYER KERNEL ELEMENT

Single instance Element inside the kernel providing the elementary services to transfer DSRC Data Structures, independent from the application running on the actual system. The KEs are the static components of the DSRC Application Layer and are allocated outside of the Application Process domain.

#### 3.1.5 APPLICATION PROCESS

An element within a DSRC system which performs the information processing of a particular RTTT application.

#### 3.1.6 APPLICATION SERVICE ELEMENT

A part of an Application Entity which provides an DSRC environment capability. The Application Service Elements describe the encapsulation of DSRC data structures by offering a defined set of Service Primitives, to manipulate the state of an Application Service Element locally as well as remotely. The realisation of an Application Service Element is the only entity of the Application Layer communicating via the DSRC link, using other Application Service Elements or directly the underlying LLC services.

### 3.1.7 BROADCAST KERNEL ELEMENT

The B-KE is responsible for the collection, broadcast and retrieval of data for multiple applications and/or multiple OBEs.

### 3.1.8 DSRC SYSTEM

A set of one or more computers, the associated software, peripherals, human operators, physical processes, information transfer means etc., that forms an autonomous whole capable of performing information processing and/or information transfer and which complies with the requirements of the DSRC Standards in its communication with other DSRC systems.

### 3.1.9 ELEMENT

Application Service Element or User Element. Elements are abstractions of data processing and data communication resources. These elements represent the parts of the communication system building up or using the Application Layer functionalities. For the purpose of addressing inside one realisation of an Application Layer (intra-system addressing) each element needs to have a Distinguished Name (see 3.4.5). If an element is an Application Layer Kernel Service User for the purpose of DSRC-wide addressing (inter-system addressing) it needs to have an Element Identifier (see 3.4.7). An element is an instance of an element class.

### 3.1.10 ENTITY

An active element within a system.

### 3.1.11 INITIALISATION KERNEL ELEMENT

The I-KE is responsible for the initialisation of the communication on the level of the Application Layer.

### 3.1.12 MANAGEMENT

The Management is the part of the application layer that supports the DSRC Communication System management. This management consists of providing the Application Layer, Data Link Layer and Physical Layer in both entities with values for the communication parameters and the collection and distribution of other information necessary for controlling the DSRC Communication System.

### 3.1.13 SERVICE

Service is a facility provided to support the requirements of the Application Layer, Application Service Elements or User Elements respectively with respect to communication.

NOTE: Services which are not related to communication and provided to the end user, referred to as application(s), are outside the scope of this Standard

### 3.1.14 TRANSFER KERNEL ELEMENT

The T-KE is responsible for the transfer of an APDU to the peer entity. It includes the needed, but extremely reduced, functionality from the Network Layer to the Presentation Layer. These are (de-)Coding to transfer syntax, (de-)Fragmentation, and (de-)Multiplexing with priority handling.

### 3.1.15 USER ELEMENT

The representation of that part of the application process which uses those application service elements needed to accomplish the communication elements of the application process.

## 3.2 COMMUNICATION

### 3.2.1 APPLICATION DATA UNIT

Data unit specified in an application and transferred between two application entities.

### 3.2.2 APPLICATION PROTOCOL DATA UNIT

Data Units exchanged between peer Application Service Elements.

### 3.2.3 APPLICATION SERVICE DATA UNIT

Data associated to an SP invocation of an Application Service Element.

### 3.2.4 LLC PROTOCOL DATA UNIT

Data Unit transmitted between two LLC protocol instances.

### 3.2.5 LLC SERVICE DATA UNIT

Vertically transferred data unit between the application layer and the LLC.

### 3.2.6 SERVICE PRIMITIVE

An abstract implementation independent interaction between a Service User and the Service Provider.

### 3.2.7 SERVICE PROVIDER

An Application Service Element or an DSRC Layer providing a special capability to Application Service Elements or a User Element by means of Service Primitives.

### 3.2.8 SERVICE USER

An Application Service Element or a User Element which makes use of a service of a Service Provider.

### 3.3 FUNCTIONALITIES

#### 3.3.1 BEACON SERVICE TABLE

On the beacon side the I-KE collects application identifiers, initial data, and protocol layer parameter relevant for the communication and assembles a beacon service table (BST). The application identifiers are stored in the BST as a priority list defining the order in which applications are served. The BST is cyclically transmitted by the beacon. The reception of the BST on the vehicle side is the initiator of each data transfer from applications on vehicle side. The vehicle's I-KE evaluates a received BST and indicates the availability of services to the corresponding APs and Application Service Elements.

#### 3.3.2 BROADCAST POOL

File, cyclically broadcast from the beacon to the vehicles. Records may be inserted independently from several Service Users.

#### 3.3.3 CODING (ALSO: ENCODING)

A function performed by the Transfer-service-provider which transfers the data from a local syntax into a common transfer syntax for all DSRC systems supporting the same applications. The peer Transfer-service-provider decodes this data from transfer syntax into its own local syntax. The common abstract description of this data is the abstract syntax (defined by means ASN.1 [ISO 8824-1]). The common rules for the encoding and decoding are the Packed Encoding Rules, PER [ISO 8825-2].

#### 3.3.4 CONCATENATION

A function performed by the Transfer Kernel Element to map multiple Application Layer Protocol Data Units or Application Layer Protocol Data Layer Fragments into one Data link Layer Service Data Unit.

#### 3.3.5 FRAGMENTATION

A function performed by the Transfer-service-provider to map one Transfer-SDU on multiple LLC-SDUs.

#### 3.3.6 HEAD OF THE LINE

Queueing discipline (also referred to as strict or fixed priority queueing), a number of queues are served in priority order, i.e. a lower priority queue is served if all higher priority queues are empty, each queue is served in First-Come-First-Serve order, each user goes head of the line of the users of lower priorities but behind all users of equal or higher priority.

#### 3.3.7 MULTIPLEXING

A function within the Transfer-service-provider by which one LLC-SAP is used to support more than one Transfer-service-user.

### 3.3.8 PROFILE

Information about capabilities and settings in the different DSRC layers and/or Application Processes. A profile is an INTEGER of ASN.1 type and identified by its value.

### 3.3.9 TIME

Time is the number of seconds from the 1/1/1970 00:00.

### 3.3.10 TRANSFER

The Transfer represents the service offered by the T-KE

### 3.3.11 VEHICLE SERVICE TABLE

The VST is the answer of the I-KE inside the OBE to the BST. It contains the identifiers of all applications present in the BST and registered in the OBE and the profile used for further communication.

## 3.4 CHARACTERISTICS OF ELEMENTS

### 3.4.1 ACTION

An operation which should be performed by the receiving Service User. Its semantic is defined as part of the element definition.

[SIST ENV 12834:2003](https://standards.iteh.ai/catalog/standards/sist/c7a9e6e2-1d3a-4c73-9628-f2a5c3001929/sist-env-12834-2003)

### 3.4.2 ATTRIBUTES

<https://standards.iteh.ai/catalog/standards/sist/c7a9e6e2-1d3a-4c73-9628-f2a5c3001929/sist-env-12834-2003>

Elements may have Attributes. An Attribute has an associated value, which may exhibit a structure, consisting of a set or sequence of data elements. The value of an Attribute may be observable, determine or reflect the Behaviour of the element. The value of an Attribute is observed or modified by sending a request to an element to read (get) or write (set) the value. Operations on Attributes are defined to be performed upon the Element that contains the Attributes and not directly upon the Attributes. The Element is able to enforce constraints on attribute values to ensure internal consistency. The definition of an Element can specify constraints between the values of individual Attributes. The syntax of an attribute is an ASN.1 type that describes how Attribute values are carried in protocol. This syntax is inherent to the Attribute and remains constant for all uses of the attribute.

### 3.4.3 ATTRIBUTE IDENTIFIER

An identifier used to distinguish an attribute of an element from all other attributes.

### 3.4.4 BEHAVIOUR

The way in which elements, attributes, notifications and actions interact with each other or with actual resources they model. It is part of the definition of an element.

The behaviour can define

- the semantics of the attributes, operations and notifications;

- the response to operations being invoked on the element;
- the circumstances under which notifications will be emitted;
- dependencies between values of particular attributes;
- the effects of relationships on the participating elements;
- consistency constraints on attributes;
- preconditions that identify the conditions when operations and notifications can be assumed to have valid meaning;
- postconditions that identify the results of the processing of a operation or the emission of a notification;
- conditions that are true for operations of the element and that are in effect for the entire lifetime of the element;
- synchronization properties of the element.

#### 3.4.5 DISTINGUISHED NAME

The name of an element, which is unambiguous in each piece of equipment. The concept of the Distinguished Name is different from the Element Identifier.

#### 3.4.6 ELEMENT CLASS (standards.iteh.ai)

A group of different Application Service Elements or User Elements which share the same definition but use different resources (e.g. memory locations) to represent their state and have different Distinguished Names and/or Element Identifiers. An Element is an Instance of an Element Class.

NOTE: In principle each Element can be seen as an Instantiation of an Element Class. The Element Class definition is directly the Element definition if the observed Element is the only instantiation.

#### 3.4.7 ELEMENT IDENTIFIER

The registered name of an Application Layer Kernel Service User which is unambiguous within the context. If another instantiation of the context is made the registered name remains the same. The DSRC-EID is the ASN.1 type used to represent and transfer this data.

#### 3.4.8 ENCAPSULATION

A relation between an Element and its Attributes and Behaviour, which represents the property that Attributes and Behaviour may be observed only through Operations on the Element or Notifications emitted by it. Encapsulation ensures that the integrity of an Element is preserved. This requires that all Operations to be performed are accomplished by sending a message to the Element. That is, the internal operation of an Element is not visible outside the element unless Attributes, Operations, or Notifications are defined to expose this information. The definition of the Element specifies what Operations can be