

INTERNATIONAL STANDARD

**ISO
7331**

First edition
1990-02-15

Ski-poles for alpine skiing — Safety requirements and test methods

iTeh STANDARD PREVIEW
Bâtons de skis alpins — Prescriptions de sécurité et méthodes d'essai
(standards.iteh.ai)

ISO 7331:1990

<https://standards.iteh.ai/catalog/standards/sist/6668c01a-1692-4ea9-965f-b477bb511b0e/iso-7331-1990>



Reference number
ISO 7331 : 1990 (E)

Foreword

ISO (the International Organization for Standardization) is a worldwide federation of national standards bodies (ISO member bodies). The work of preparing International Standards is normally carried out through ISO technical committees. Each member body interested in a subject for which a technical committee has been established has the right to be represented on that committee. International organizations, governmental and non-governmental, in liaison with ISO, also take part in the work. ISO collaborates closely with the International Electrotechnical Commission (IEC) on all matters of electrotechnical standardization.

Draft International Standards adopted by the technical committees are circulated to the member bodies for approval before their acceptance as International Standards by the ISO Council. They are approved in accordance with ISO procedures requiring at least 75 % approval by the member bodies voting.

International Standard ISO 7331 was prepared by Technical Committee ISO/TC 83, *Sports and recreational equipment*.

[ISO 7331:1990](https://standards.iteh.ai/catalog/standards/sist/6668c01a-1692-4ea9-965f-100000000000/iso-7331-1990)

[https://standards.iteh.ai/catalog/standards/sist/6668c01a-1692-4ea9-965f-](https://standards.iteh.ai/catalog/standards/sist/6668c01a-1692-4ea9-965f-100000000000/iso-7331-1990)

This second edition cancels and replaces the first edition (ISO 7331:1983), the following significant technical changes having been made:

- in clause 1, the lower limit of group B is now $l_N > 900$ mm;
- mention is included of special designs;
- in clause 6, first paragraph, test lengths in groups A and B have been modified;
- in 7.5.2 the impact area of group C is at least 12 cm²;
- in 7.7.2 test lengths have been modified;
- in 7.8.4, second paragraph, examples have been added;
- a new subclause 7.9.3 concerning hardness has been added;
- in clause 8 a second subclause concerning marking of special designs has been added.

© ISO 1990

All rights reserved. No part of this publication may be reproduced or utilized in any form or by any means, electronic or mechanical, including photocopying and microfilm, without permission in writing from the publisher.

International Organization for Standardization
Case postale 56 • CH-1211 Genève 20 • Switzerland

Printed in Switzerland

Ski-poles for alpine skiing — Safety requirements and test methods

1 Scope

This International Standard specifies the minimum requirements for safety in ski-poles for alpine skiing and gives test methods to check conformity with these requirements.

It applies to ski-poles for alpine skiing in the following ranges of nominal length, l_N (see clause 3):

- group A, $l_N \geq 1\,100$ mm (adults' poles)
- group B, $1\,100$ mm $> l_N \geq 900$ mm (junior poles)
- group C, $l_N < 900$ mm (children's toy-poles)

Special designs may deviate from this International Standard, but are required to be marked durably as special designs (see 8.2).

2 Normative references

The following standards contain provisions which, through reference in this text, constitute provisions of this International Standard. At the time of publication, the editions indicated were valid. All standards are subject to revision, and parties to agreements based on this International Standard are encouraged to investigate the possibility of applying the most recent editions of the standards indicated below. Members of IEC and ISO maintain registers of currently valid International Standards.

ISO 554 : 1976, *Standard atmospheres for conditioning and/or testing — Specifications.*

ISO 6508 : 1986, *Metallic materials — Hardness test — Rockwell test (scales A — B — C — D — E — F — G — H — K).*

3 Terms, symbols and units

3.1 Terms

Terms used to designate the different parts of a ski-pole are given in figure 1.

There are two types of grips for ski-poles:

- grips with a strap;
- strapless grips.

3.2 Symbols and units

The symbols used in figure 2 relate to the following concepts, which shall be expressed in the units given:

A_G = upper surface of the grip, in square centimetres (impact area)

$-F_z$ = compressive force in the axis of the ski-pole, in newtons

l_T = total length, in millimetres

l_N = nominal or effective length measured from the tip to the upper surface of the fist, in millimetres

l_H = length measured from the tip to the middle of the hand, in millimetres

l_B = length measured from the tip to the lower surface of the basket, in millimetres

d_B = maximum diameter of the basket, in millimetres

The nominal length l_N shall be marked on the ski-pole (see clause 8).

The lengths l_N and l_H are determined by means of an average hand, with a width of

group A: 93 mm

group B: 73 mm

group C: 57 mm

4 Materials

The materials used shall meet the requirements prescribed in this International Standard.

5 Test conditions

Unless otherwise specified, the test shall be carried out as a type test in the standard atmosphere indicated in ISO 554 with reduced tolerances.

The reference value for the quasi-static structure of force is

$$\frac{dF}{dt} < 100 \text{ N/s}$$

The test equipment shall be such that all measurable variables such as forces, temperatures, angles, lengths, surfaces, weights and time of oscillation can be measured or determined to the following accuracies:

Forces, weights	$\pm 2 \%$
Temperatures	$\pm 2 \text{ }^\circ\text{C}$
Angles	$\pm 1^\circ$
Lengths of poles	$\pm 1 \text{ mm}$
Radii and other lengths	$\pm 0,2 \text{ mm}$

6 Test sample

For the test, three poles each from the longest and from the shortest lengths of one group shall be submitted to the testing establishment.

In addition, for testing of group A three poles of 1 200 mm length and of group B three poles of 1 000 mm length shall be submitted to the testing establishment.

One long pole and one short pole shall be selected for the tests in accordance with 7.2 to 7.9.2.

If one test sample fails these tests, the tests may be repeated with two further test poles, both of which then have to pass the tests.

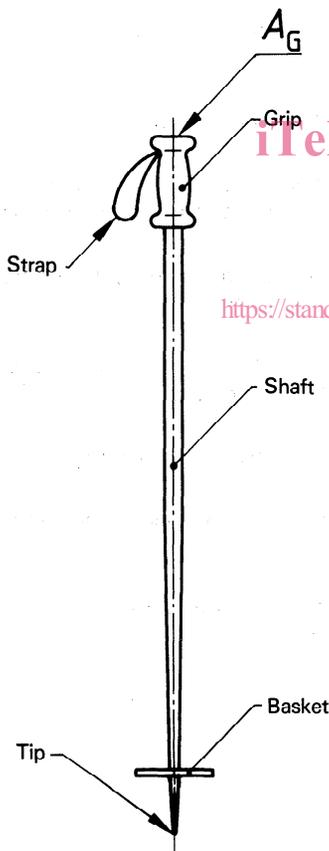

Figure 1 — Ski-pole — Terms

iteh STANDARD PREVIEW
(standards.iteh.ai)
ISO 7331:1990
<https://standards.iteh.ai/catalog/standards/sist/6668c01a-1692-4ea9-965f-b477bb511b0e/iso-7331-1990>

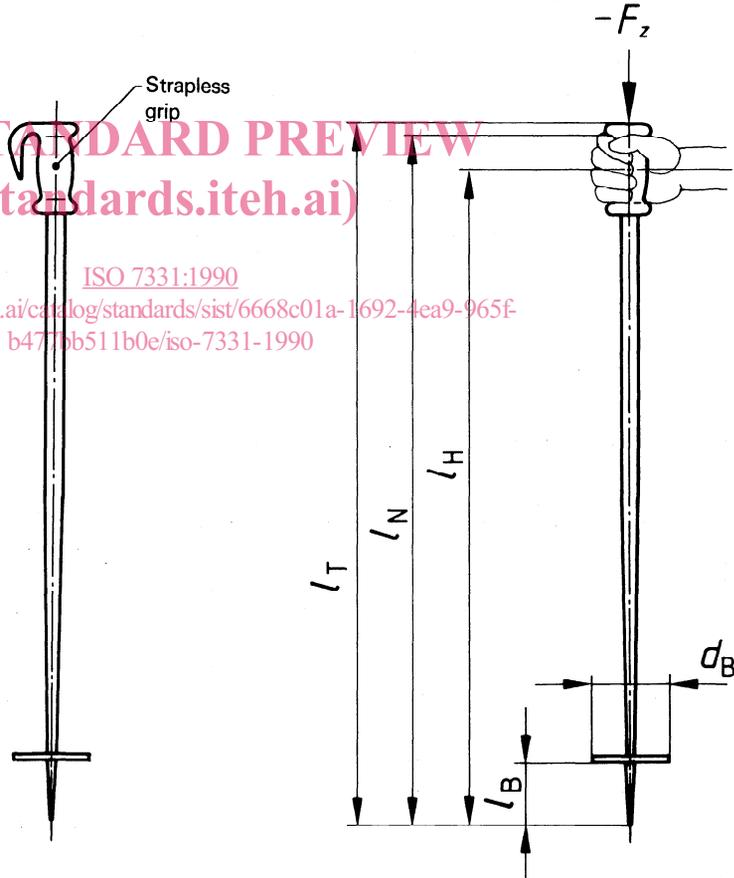

Figure 2 — Centre of rotation and dimensions

7 Technical requirements for safety and methods of test

No.	Property	Requirement	Method of test
7.1	Nominal length	The nominal length l_N shall not vary from the given length by more than ± 10 mm. Furthermore the lengths of one pair of ski-poles shall not differ by more than 7 mm.	Determine lengths of all test samples indicated in clause 6.
7.2	Outward design	Sharp design (except the tip) and rough surfaces, which might cause injury, shall be avoided.	Check visually.
7.3	Anti-catching design	The ski-pole shall be so designed that no dangerous strain can be transmitted to the wrist and arm of the skier, should the pole get caught during skiing. This requirement can be met by a design according to 7.6.3 or 7.8.4, or by a strapless grip.	Test according to 7.6.3 or 7.8.4, or visual and functional test.
7.4	Release mechanism	If so equipped a release mechanism shall be manufactured so that correct functioning is guaranteed in environmental conditions encountered during skiing.	
7.4.1	Temperature and ice conditions	<p>If a release mechanism is provided in the shaft, the compressive force in the axis of the pole necessary to cause the release at a temperature of -20 °C and in icy conditions, and at a temperature of 20 °C shall not vary by more than 30 %.</p> <p>In addition, the release force at -20 °C and in icy conditions shall not exceed values given in 7.6.3.</p>	<p>Determine the release force at room temperature five times per function on one test sample and calculate the mean value.</p> <p>Store the release mechanism at a temperature of -20 °C until this temperature is reached.</p> <p>Then determine the release force once and compare it with the mean value at 20 °C.</p> <p>Again determine the release force at room temperature five times on one test sample and calculate the mean value.</p> <p>Spray the vertically placed ski-pole with water at 10 °C or more for 1 min from a distance of 1 m, and then store the pole vertically at -20 °C until it reaches this temperature.</p> <p>Then determine the release force once and compare it with the mean value at 20 °C.</p>
7.4.2	Fatigue conditions	The release mechanisms shall be protected against wear so that they still function correctly after 100 releases. The release forces shall not vary by more than 20 % after the fatigue test.	Carry out 100 releases on each release mechanism; compare the mean value of the first five releases with the mean value of the last five.
7.5	Grip		
7.5.1	Shape	The shape of the grip shall be designed to facilitate good control of the pole, i.e. the grip shall be shaped to the hand and not be slippery. With all grips, whether straps are included or not, the shape of the moulded portion shall not be such as to force the thumb outward or upward, beyond the edge of the impact area A_G of the top of the handle/grip.	Visual and manual testing.

No.	Property	Requirement	Method of test
7.5.2	Impact area	The impact area A_G shall be group A: at least 25 cm ² group B: at least 18 cm ² group C: at least 12 cm ²	Designate the largest section, taken from the outer contour at a level between 0 and 10 mm from the upper edge of the grip and at a slope of between 0 and 10° to the perpendicular; this shall be the impact area. In the case of deformable surfaces of the grip, this measurement can be carried out at a compressive force of 400 N.
7.5.3	Edges	Edges on the grip which could cause injury shall have a radius of at least 2,0 mm.	Visual and dimensional testing.
7.5.4	Piercing resistance	The piercing resistance of the impact area A_G to the top of the shaft, that is the force necessary for the shaft to pierce the impact area upwards, shall be higher by at least 100 % than the maximum compressive force, or than the maximum release force of poles with a release mechanism.	Press a test sample against a fixed abutment by means of a plate (see figure 3). When the double compressive force, determined according to 7.7.2, is applied, the shaft shall not pierce the end of the grip. The test shall be carried out quasi-statically.

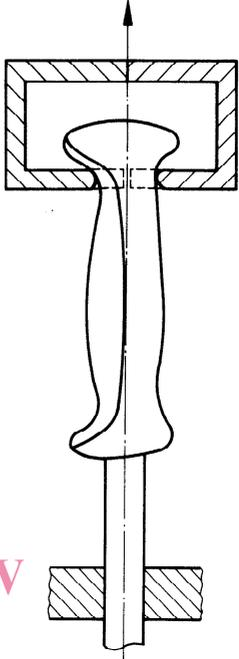

Figure 3 – Test arrangement for piercing resistance

iTeh STANDARD PREVIEW
(standards.iteh.ai)

ISO 7331:1990

<https://standards.iteh.ai/catalog/standards/sist/6668c01a-1692-4ea9-9671-b477bb511b0e/iso-7331-1990>

No.	Property	Requirement	Method of test
7.5.5	Pulling-off force	The force needed to pull the grip from the shaft shall be group A: at least 500 N group B: at least 400 N group C: at least 300 N	Carry out the test on a test sample in accordance with figure 4. The test shall be carried out quasi-statically.  <p style="text-align: center;">Figure 4 – Test arrangement for pulling-off force</p>
7.5.6	Strapless grips	The bow of strapless grips shall be designed in such a way that catching or twisting the wrist is avoided.	Check visually.
7.6	Straps		
7.6.1	Width	Straps with a supporting function shall have the following width where near the hand: group A: at least 16 mm group B: at least 14 mm group C: at least 12 mm	Visual and dimensional test.

iTeh STANDARD PREVIEW
(standards.iteh.ai)

ISO 7331:1990

<https://standards.iteh.ai/catalog/standards/sis/66680116924e0965f1651180511190>

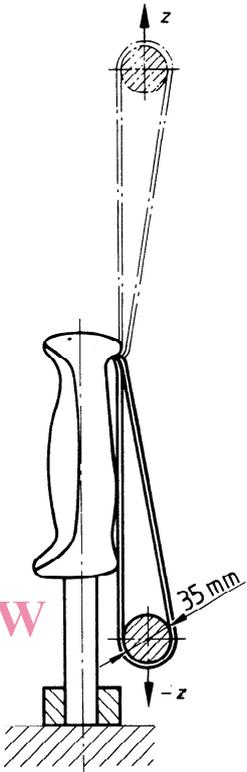
No.	Property	Requirement	Method of test
7.6.2	Minimum strain in support direction	<p>Straps with a supporting function (i.e. groups A and B) shall withstand a force in the loading direction $-z$ of at least 350 N.</p> <p>Straps in group C have no supporting function.</p>	<p>Carry out the test quasi-statically according to figure 5 by applying the force in the direction $-z$.</p>  <p style="text-align: center;">Figure 5 – Test arrangement for the strap</p>
7.6.3	Release function	<p>Straps with a release function shall have the following range of release values in the direction z within a range of temperature from 20 °C to -5 °C:</p> <p style="padding-left: 20px;">group A: 80 N to 240 N group B: 60 N to 180 N</p> <p>NOTE — Further evaluation of accident statistics is needed to determine more extensive requirements concerning the direction of strap release from different types of fall, etc.</p>	<p>Determine release forces in direction z quasi-statically according to 7.4 and figure 5.</p>

iTeh STANDARD PREVIEW
(standards.iteh.ai)

ISO 7331:1990

<https://standards.iteh.ai/catalog/standards/sist/6668c01a-1692-4ea9-965f-b477bb511b0e/iso-7331-1990>

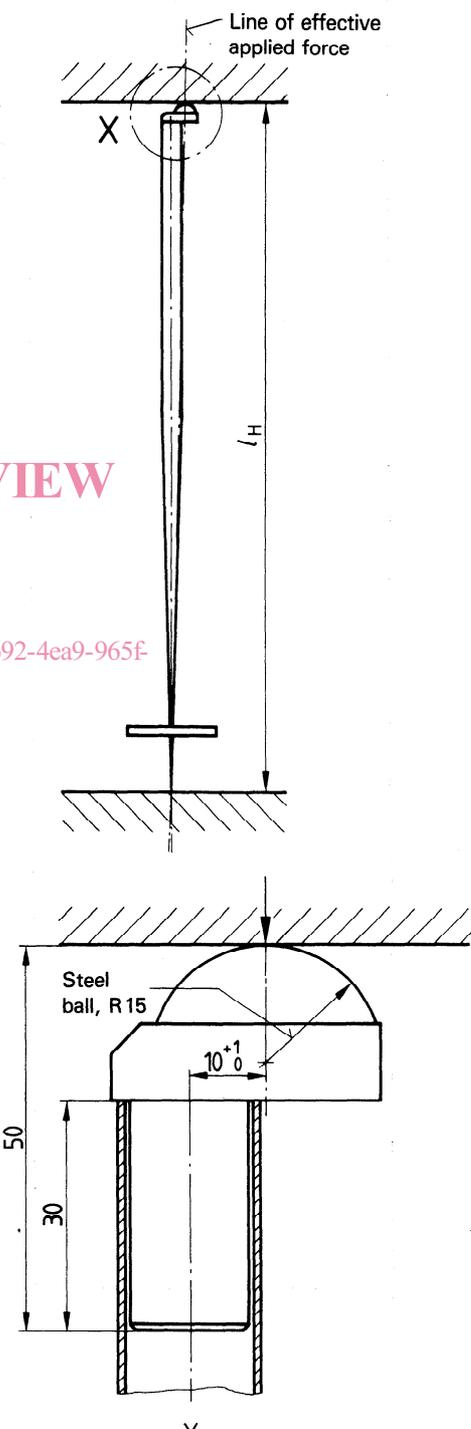
No.	Property	Requirement	Method of test
7.7	Shaft		
7.7.1	Minimum compressive force	<p>The shaft shall be designed to withstand compressive forces and bending moments occurring during all aspects of skiing without plastic deformation or fracture.</p> <p>No permanent deformation shall occur when loading the pole with a compressive force in the axis of the pole of</p> <p>group A: 500 N group B: 450 N group C: 300 N</p>	<p>Test the longest ski-pole of one series, taking l_H as the test length. Carry out the test quasi-statically between two parallel plates and with the pole fixed off-centre (see figure 6). Test bent poles in such a way that buckling is promoted.</p> <p>Dimensions in millimetres</p>  <p>Figure 6 — Test arrangement for the determination of the minimum compressive force</p>

iTeh STANDARD PREVIEW
(standards.iteh.ai)

ISO 7331:1990

<https://standards.iteh.ai/catalog/standards/sist/6668c01a-1692-4ea9-965f-b477bb511b0e/iso-7331-1990>