



Designation: C 1424 – 99

Standard Test Method for Monotonic Compressive Strength of Advanced Ceramics at Ambient Temperature¹

This standard is issued under the fixed designation C 1424; the number immediately following the designation indicates the year of original adoption or, in the case of revision, the year of last revision. A number in parentheses indicates the year of last reapproval. A superscript epsilon (ϵ) indicates an editorial change since the last revision or reapproval.

1. Scope

1.1 This test method covers the determination of compressive strength including stress-strain behavior, under monotonic uniaxial loading of advanced ceramics at ambient temperature. This test method is restricted to specific test specimen geometries. In addition, test specimen fabrication methods, testing modes (load or displacement), testing rates (load rate, stress rate, displacement rate, or strain rate), allowable bending, and data collection and reporting procedures are addressed. Compressive strength as used in this test method refers to the compressive strength obtained under monotonic uniaxial loading. Monotonic loading refers to a test conducted at a constant rate in a continuous fashion, with no reversals from test initiation to final fracture.

1.2 *This standard does not purport to address all of the safety concerns, if any, associated with its use. It is the responsibility of the user of this standard to establish appropriate safety and health practices and determine the applicability of regulatory limitations prior to use.*

1.3 This test method is intended primarily for use with advanced ceramics that macroscopically exhibit isotropic, homogeneous, continuous behavior. While this test method is intended for use on monolithic advanced ceramics, certain whisker- or particle-reinforced composite ceramics as well as certain discontinuous fiber-reinforced composite ceramics may also meet these macroscopic behavior assumptions. Generally, continuous fiber ceramic composites (CFCCs) do not macroscopically exhibit isotropic, homogeneous, continuous behavior and, application of this test method to these materials is not recommended.

1.4 Values expressed in this test method are in accordance with the International System of Units (SI) and Practice E 380.

2. Referenced Documents

2.1 ASTM Standards:

C 773 Test Method for Compressive (Crushing) Strength of Fired Whiteware Materials²

C 1145 Terminology on Advanced Ceramics³

D 695 Test Method for Compressive Properties of Rigid Plastics⁴

E 4 Practices for Force Verification of Testing Machines⁵

E 6 Terminology Relating to Methods of Mechanical Testing⁵

E 83 Practice for Verification and Classification of Extensometers⁵

E 337 Test Method for Measured Humidity with Psychrometer (the Measurement of Wet-and Dry-Bulb Temperatures)⁶

E 380 Practice for Use of International System of Units (SI) (the Modernized Metric System)⁷

E 1012 Practice for Verification of Specimen Alignment Under Tensile Loading⁵

3. Terminology

3.1 *Definitions*—The definitions of terms relating to compressive testing appearing in Terminology E 6, Test Method D 695, and Terminology C 1145 may apply to the terms used in this test method. Pertinent definitions as listed in Practice E 1012, Terminology C 1145, and Terminology E 6 are shown in the following with the appropriate source given in parentheses. Additional terms used in conjunction with this test method are defined in the following.

3.1.1 *advanced ceramic, n*—a highly engineered, high-performance predominately nonmetallic, inorganic, ceramic material having specific functional attributes. **(C 1145)**

3.1.2 *axial strain, n [L/L]*—the average longitudinal strains measured at the surface on opposite sides of the longitudinal axis of symmetry of the specimen by two strain-sensing devices located at the mid length of the reduced section. **(E 1012)**

3.1.3 *bending strain, n [L/L]*—the difference between the strain at the surface and the axial strain. In general, the bending strain varies from point to point around and along the reduced section of the test specimen. **(E 1012)**

¹ This test method is under the jurisdiction of ASTM Committee C-28 on Advanced Ceramics and is the direct responsibility of Subcommittee C28.01 on Properties and Performance.

Current edition approved May 10, 1999. Published September 1999.

² *Annual Book of ASTM Standards*, Vol 15.02.

³ *Annual Book of ASTM Standards*, Vol 15.01.

⁴ *Annual Book of ASTM Standards*, Vol 08.01.

⁵ *Annual Book of ASTM Standards*, Vol 03.01.

⁶ *Annual Book of ASTM Standards*, Vol 11.03.

⁷ *Annual Book of ASTM Standards*, Vol 14.02.

3.1.4 *breaking load, n [F]*—the load at which fracture occurs. (E 6)

3.1.5 *compressive strength, n [F/L²]*—the maximum compressive stress which a material is capable of sustaining. Compressive strength is calculated from the maximum load during a compression test carried to rupture and the original cross-sectional area of the specimen. (E 6)

3.1.6 *gage length, n [L]*—the original length of that portion of the specimen over which strain or change of length is determined. (E 6)

3.1.7 *modulus of elasticity, n [F/L²]*—the ratio of stress to corresponding strain below the proportional limit. (E 6)

3.1.8 *percent bending, n*—the bending strain times 100 divided by the axial strain. (E 1012)

4. Significance and Use

4.1 This test method may be used for material development, material comparison, quality assurance, characterization, and design data generation.

4.2 Generally, resistance to compression is the measure of the greatest strength of a monolithic advanced ceramic. Ideally, ceramics should be compressively stressed in use, although engineering applications may frequently introduce tensile stresses in the component. Nonetheless, compressive behavior is an important aspect of mechanical properties and performance. Although tensile strength distributions of ceramics are probabilistic and can be described by a weakest link failure theory, such descriptions have been shown to be inapplicable to compressive strength distributions in at least one study (1).⁸ However, the need to test a statistically significant number of compressive test specimens is not obviated. Therefore, a sufficient number of test specimens at each testing condition is required for statistical analysis and design.

4.3 Compression tests provide information on the strength and deformation of materials under uniaxial compressive stresses. Uniform stress states are required to effectively evaluate any nonlinear stress-strain behavior which may develop as the result of cumulative damage processes (for example, microcracking) which may be influenced by testing mode, testing rate, processing or compositional effects, microstructure, or environmental influences.

4.4 The results of compression tests of test specimens fabricated to standardized dimensions from a particular material or selected portions of a part, or both, may not totally represent the strength and deformation properties in the entire, full-size product or its in-service behavior in different environments.

4.5 For quality control purposes, results derived from standardized compressive test specimens may be considered indicative of the response of the material from which they were taken for given primary processing conditions and post-processing heat treatments.

5. Interferences

5.1 Test environment (vacuum, inert gas, ambient air, and so forth) including moisture content (for example, relative humid-

ity) may have an influence on the measured compressive strength. Testing to evaluate the maximum strength potential of a material can be conducted in inert environments or at sufficiently rapid testing rates, or both, so as to minimize any environmental effects. Conversely, testing can be conducted in environments, test modes, and test rates representative of service conditions to evaluate material performance under use conditions. When testing is conducted in uncontrolled ambient air with the intent of evaluating maximum strength potential, relative humidity and temperature must be monitored and reported.

5.2 Fabrication of test specimens can introduce dimensional variations which may have pronounced effects on compressive mechanical properties and behavior (for example, shape and level of the resulting stress-strain curve, compressive strength, induced bending, and so forth). Machining effects introduced during test specimen preparation can be an interfering factor in the determination of ultimate strength of pristine material (that is, increased frequency of loading block related fractures (see Fig. 1) compared to volume-initiated fractures). Surface preparation can also lead to the introduction of residual stresses. Universal or standardized test methods of surface preparation do not exist. It should be understood that final machining steps may or may not negate machining damage introduced during the initial machining. Note that final compressive fracture of advanced ceramics can be attributed to the interaction of large numbers of microcracks that are generated in the volume of the material and ultimately lead to loss of structural integrity. (1,2). Therefore, although surface roughness in the gage section of the test specimen is not as critical for determining maximum strength potential as it is for flexure or tension tests of advanced ceramics, test specimen fabrication history may play an important role in the measured compressive strength distributions and should be reported. In addition, the nature of fabrication used for certain advanced ceramics (for example, pressureless sintering, hot pressing) may require the testing of test specimens with gage sections in the as-processed condition (that is, it may not be possible or desired/required to machine some test specimen surfaces not directly in contact with test

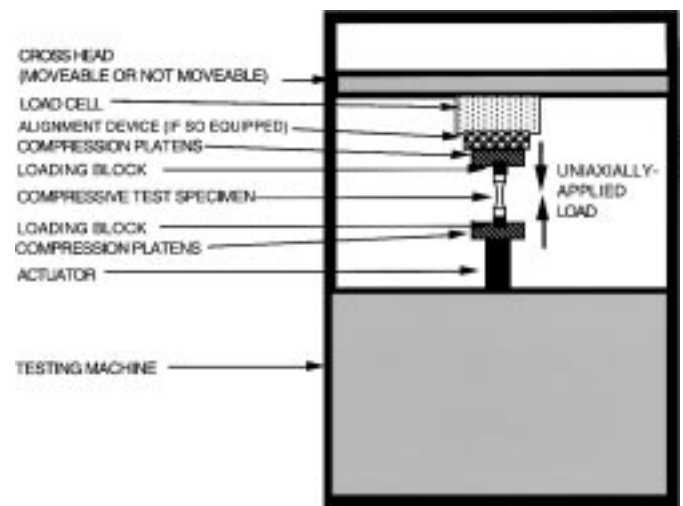
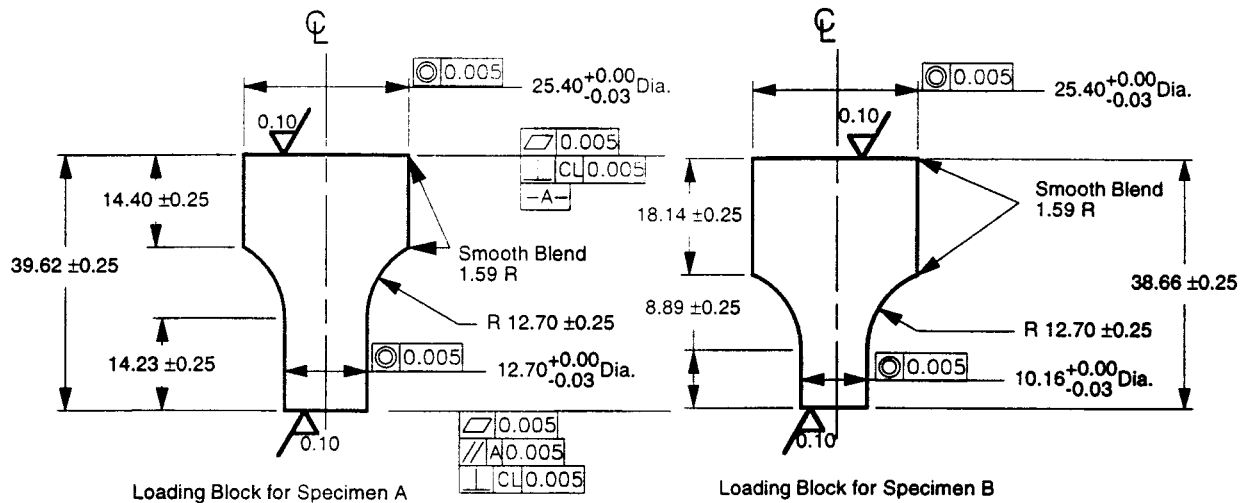

FIG. 1 Schematic Diagram of One Possible Apparatus for Conducting a Uniaxially Loaded Compression Test

⁸ The boldface numbers in parenthesis refer to the list of references at the end of this test method



NOTE 1—Dimensions in millimetres; surface finish in micrometres.
FIG. 3 Loading Blocks for Recommended Compression Test Specimen Sizes A and B

6.2.1.2.1 Lateral strain in the loading block (ϵ_{LB}) at the loading block/test specimen interface shall be less than the lateral strain in the compression test specimen end (ϵ_{SE}) at the loading block/test specimen interface to prevent lateral splitting in the test specimen such that:

$$\epsilon_{LB} < \epsilon_{SE} \quad (1)$$

where:

$\epsilon_{LB} = -\nu_{LB}\sigma_{LB} / E_{LB}$ (ν_{LB} = Poisson's ratio of the loading block material, σ_{LB} = longitudinal stress in the loading block at the loading block/test specimen interface, and E_{LB} = elastic modulus of the loading block material) and

$\epsilon_{SE} = -\nu_S\sigma_{SE} / E_S$ (ν_S = Poisson's ratio of the compression test specimen material, σ_{SE} = longitudinal stress in the compression test specimen at the loading block/test specimen interface, and E_S = elastic modulus of the compression test specimen material).

Since, $\sigma_{LB} = \sigma_{SE}$ are presumably equal at the loading block/test specimen interface, Eq 1 can be rewritten as:

$$\frac{\nu_{LB}}{E_{LB}} < \frac{\nu_S}{E_S} \quad (2)$$

6.2.1.2.2 The mean compressive strength of the loading block material, \bar{S}_{UC-LB} , shall be greater than the anticipated mean compression strength of the compression test specimen material, \bar{S}_{UC-S} , such that:

$$\bar{S}_{UC-LB} > \bar{S}_{UC-S} \quad (3)$$

6.3 Alignment—Although limits on angularity and concentricity of loading fixtures are given in 6.2.1.1, other variables may affect final nonuniformity of the stress in the specimen gage section. As a result, quantification of this nonuniformity (that is, bending) is accomplished using a well-accepted and documented parameter, percent bending. Therefore, at a mini-

um, quantify and verify alignment of the testing system at the beginning and end of a test series unless the conditions for verifying alignment as detailed in A1.1 are otherwise met. An additional verification of alignment is recommended, although not required, at the middle of the test series. Use either a dummy or actual test specimen and the alignment verification procedures detailed in the appendix. Allowable bending requirements are discussed in 6.5. Equip compression test specimens used for alignment verification with a recommended four separate longitudinal strain gages located circumferentially on a single cross-sectional plane to determine bending contributions from both eccentric and angular misalignment of the loading fixtures. Ideally, the material of the verification test specimen should be identical to that being tested. In addition, dummy test specimens used for alignment verification should have the same geometry and dimensions of the actual test specimens as well as similar mechanical properties as the test material to ensure similar axial and bending stiffness characteristics as the actual test specimen and material.

NOTE 1—A test series is interpreted to mean a discrete group of tests on individual test specimens conducted within a discrete period of time on a particular material configuration, test specimen geometry, test condition, or other uniquely definable qualifier (for example, a test series composed of Material A comprising five test specimens of Geometry B tested at a fixed rate in displacement control to final fracture in ambient air).

6.4 Strain Measurement—Although strain measurements are not required in this test method, if measured on the actual test specimen, determine strain by means of either expendable strain gages attached to the test specimen or noncontacting extensometry. Since fracture of test specimens in compression is spectacular, conventional contacting extensometers would in all likelihood be damaged or destroyed and are therefore not recommended. If Poisson's ratio is to be determined, instrument the test specimen to measure strain in both longitudinal and lateral directions. Stacked, biaxial strain gages are recommended for this purpose. Choose the strain gages, surface

preparation, and bonding agents so as to provide adequate performance on the subject material without introducing spurious surface damage which may affect the test results. In addition, employ suitable strain gage conditioning and recording equipment.

6.4.1 If contacting extensometers are used to record strain in the initial (that is, linear) part of the stress-strain curve, remove the extensometer prior to test specimen fracture. All extensometers, whether contacting or noncontacting, shall be in accordance with Practice E 83, Class B-1 requirements. Extensometers shall be calibrated periodically in accordance with Practice E 83. For contacting extensometers, the contact should cause no damage to the test specimen surface. In addition and if applicable, support the weight of the extensometer so as not to introduce bending greater than that allowed in 6.5'.

6.4.2 Although buckling is minimized when using the recommended test specimens of this test method, an additional recommendation but not requirement for the actual testing is to monitor possible buckling using strain determined directly from strain gages. Four strain gages mounted 90° apart around the circumference of the test specimen can be used to monitor incidences of bending or eccentricity and, hence, tendency to buckling. Buckling can be detected when the strain on one side of the test specimen reverses (decreases) while the strain on the other side increases rapidly.

6.5 Allowable Bending—Although the test specimens in Fig. 4 are designed to minimize incidences of load-induced buckling (2), axial misalignment or the introduction of bending, due either to eccentricity or angular misalignment, will produce a geometric instability in the compressive test specimen leading to buckling and measured compressive strengths less than the actual compressive strength. Bending can be measured using either strain gages or other strain measurement devices located around the circumference of the test specimen or can be inferred from evidence in fractured test specimens

that exhibit vertical cracking (splitting) due to tensile stresses which develop at the ends leading to chipping and cracking of the test specimen.

6.5.1 Actual studies of the effect of bending on the compressive strength distributions of advanced ceramics do not exist, although the test specimen and fixture tolerances given in this test method are intended to minimize non-uniaxial and nonuniform stresses. Until such information is forthcoming for advanced ceramics, this test method adopts a conservative recommendation of the lowest achievable percent bending for compressive testing. Therefore, in this test method the maximum allowable percent bending determined either at fracture or during an alignment verification is 2.5 (3) although the maximum recommended percent is 1. However, it should be noted that unless all test specimens are properly strain gaged and percent bending monitored up to fracture, there will be no record of percent bending at the onset of fracture for each test specimen (although test specimens which exhibit vertical splitting are good indicators of excessive bending). Therefore, verify the testing system using a procedure such as the one detailed in the appendix such that percent bending does not exceed 2.5 at the average strain equal to either one half the anticipated strain at fracture or a strain of -0.0005 (that is, -500 microstrain) whichever is greater. At a minimum, conduct this verification at the beginning and end of each test series in accordance with 6.3. An additional verification of alignment is recommended, although not required, at the middle of the test series.

6.6 Data Acquisition—At the minimum, obtain an autographic record of applied load and gage section deformation (or strain) versus time. Either analog chart recorders or digital data acquisition systems can be used for this purpose although a digital record is recommended for ease of later data analysis. Ideally, an analog chart recorder or plotter should be used in conjunction with the digital data acquisition system to provide an immediate record of the test as a supplement to the digital

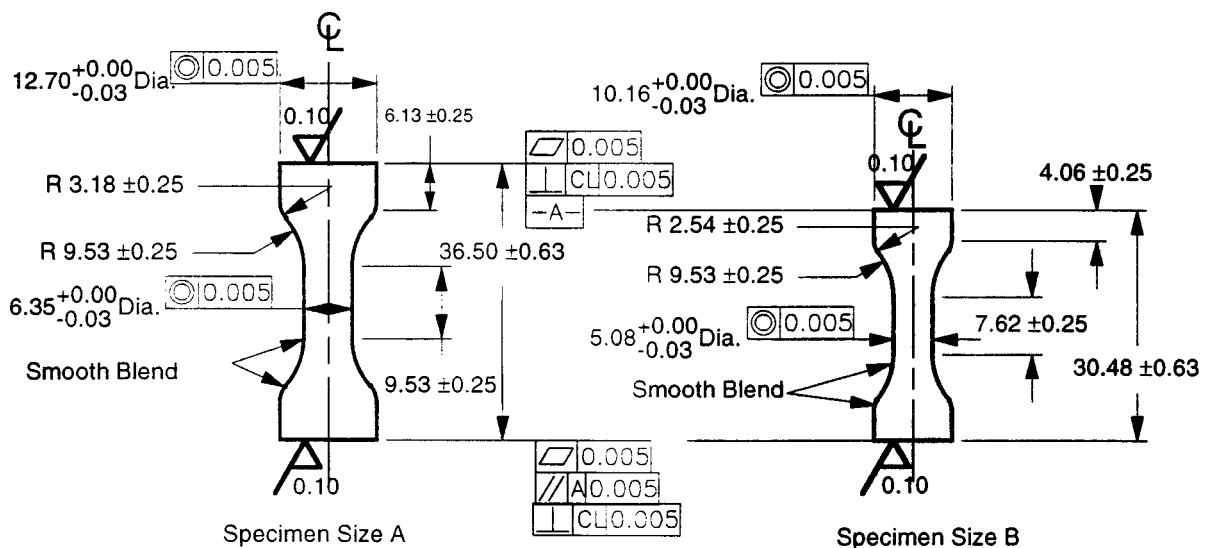

NOTE 1—Dimensions in millimetres; surface finish in micrometres.
FIG. 4 Recommended Compressive Test Specimen Sizes A and B

record. Recording devices should be accurate to within $\pm 1\%$ of the selected range for the testing system including readout unit, as specified in Practices E 4, and should have a minimum data acquisition rate of 10 Hz with a response of 50 Hz deemed more than sufficient.

6.6.1 Record strain or deformation of the gage section, or both, either similarly to the load or as independent variables of load. Cross-head displacement of the test machine may also be recorded but should not be used to define displacement or strain in the gage section.

6.7 *Dimension-Measuring Devices*—Micrometers and other devices used for measuring linear dimensions shall be accurate and precise to at least one half the smallest unit to which the individual dimension is required to be measured. For the purposes of this test method, cross-sectional dimensions should be measured to within 0.01 mm requiring dimension-measuring devices with accuracies of 0.005 mm.

7. Precautionary Statement

7.1 Fractures of compressively loaded advanced ceramics occur at much greater loads and strain energies than in tensile loaded advanced ceramics. Compressive fracture in high-strength advanced ceramics will generate the release of many uncontrolled fragments. Thick (6 to 13 mm) polycarbonate shielding or equivalent is recommended for operator safety.

7.2 To limit the uncontrolled motion of the compression fixture parts, temporarily bind the loading blocks to the compression platen using a strip or strips of adhesive tape around the loading block and adhered to the compression platen (see Fig. 1). Do not place any substance between the loading block and the compression platen contact surfaces.

7.3 Compression fractures often create fine particles which may be a health hazard. Materials containing whiskers, small fibers, or silica particles may also cause health hazards when compression tested. For such materials, the operator is advised to consult the material safety data sheet for guidance prior to testing. Suitable ventilation or masks may be warranted.

8. Test Specimen

8.1 *Test Specimen Geometries*:

8.1.1 Fig. 4 illustrates two contoured, cylindrical test specimens similar to those successfully used for compression tests of advanced ceramics (2-7). Contoured test specimens have been shown through finite element analyses (4) to have uniform stresses in the gage section with minimal stress concentrations at the geometric transitions and are therefore recommended in this test method. Although straight-sided test specimens (right circular cylinders) as recommended in Test Method C 773 for whitewares have been shown to produce nonuniform stresses with subsequent fracture at stresses not representative of actual compressive strengths (3,6), and are therefore not recommended in this test method for advanced ceramics, possible configurations for this geometry are discussed in Appendix X2. Specimen B as shown in Fig. 4 can be used when the load capacity of the test machine may be exceeded by use of Specimen A.

8.1.2 Contoured test specimen dimensions or geometries (2) other than those shown in Fig. 4 may be used, however the

effect of any stress concentrations should be considered when developing a compressive test specimen geometry.

8.2 *Test Specimen Preparation*:

8.2.1 *Application-Matched Machining*—The gage section of the compressive test specimen will have the same surface/edge preparation as that given to a service component. Unless the process is proprietary, the report shall be specific about the stages of material removal, wheel grits, wheel bonding, amount of material removed per pass, and type of coolant used. Regardless of the application-matched procedure used to fabricate the surface of the gage section, the concentricity of the gage section as well as the surface roughness and flatness of the end faces shall be as specified in Fig. 4. This surface roughness can be achieved using lapping or a similar type of machining operation.

8.2.2 *Customary Practices*—In instances where a customary machining procedure has been developed that is completely satisfactory for a class of materials (that is, it induces no unwanted surface/subsurface damage or residual stresses), this procedure may be used to make the gage section of the compression test specimens. Unless the process is proprietary, the report shall be specific about the stages of material removal, wheel grits, wheel bonding, amount of material removed per pass, and the type of coolant used. Regardless of the customary machining procedure used to produce the surface of the gage section, the concentricity of the gage section as well as the surface roughness and flatness of the end faces shall be as specified in Fig. 4. This surface roughness can be achieved using lapping or a similar type of machining operation.

8.2.3 *Alternative Procedure*—In instances where 8.2.1 or 8.2.2 are not appropriate, 8.2.3.1-8.2.3.5 shall apply. The test report shall be specific about the stages of material removal, wheel grits, wheel bonding, amount of material removed per pass, and type of coolant used. Regardless of the alternative procedure used to fabricate the surface of the gage section, the concentricity of the gage section as well as the surface roughness and flatness of the end faces shall be as specified in Fig. 4. This surface roughness can be achieved using lapping or a similar type of machining operation.

NOTE 2—Final compressive fracture of advanced ceramics can be attributed to the interaction of large numbers of microcracks that are generated in the volume of the material and ultimately lead to loss of structural integrity (1,2). Therefore, surface roughness in the gage section of the test specimen is not as critical for determining maximum compressive strength potential as it is for flexural or tensile tests of advanced ceramics.

8.2.3.1 Perform all grinding or cutting with ample supply of appropriate filtered coolant to keep the workpiece and grinding wheel constantly flooded and particles flushed. Grinding can be done in at least two stages, ranging from coarse to fine rate of material removal. All cutting can be done in one stage appropriate for the depth of cut.

8.2.3.2 Stock removal rate shall not exceed 0.03 mm per pass up to the last 0.06 mm of material removed using diamond tools that have between 320 and 500 (or 600) grit. Remove equal stock from each surface where applicable.

8.2.3.3 Because of the axial symmetry of the contoured compressive test specimen, fabrication of the test specimens is