International Standard



7375/1

INTERNATIONAL ORGANIZATION FOR STANDARDIZATION • МЕЖДУНАРОДНАЯ ОРГАНИЗАЦИЯ ПО СТАНДАРТИЗАЦИИ • ORGANISATION INTERNATIONALE DE NORMALISATION

Road vehicles — Coiled pipe assemblies for pneumatic braking connection between motor vehicles and towed vehicles —

Part 1 : Dimensions

Véhicules routiers — Tuyaux flexibles spiralés munis de leur raccord pour la liaison de freinage pneumatique entre automobiles et véhicules tractés — Partie 1 : Dimensions

ITeH STANDARD PREVIEW

(standards.iteh.ai)

First edition — 1982-02-01

[ISO 7375-1:1982](https://standards.iteh.ai/catalog/standards/sist/f40e76b5-095d-4546-842a-0fb897058059/iso-7375-1-1982)

<https://standards.iteh.ai/catalog/standards/sist/f40e76b5-095d-4546-842a-0fb897058059/iso-7375-1-1982>

UDC 629.113-592.5 : 621.643.2 : 629.1.013.5

Ref. No. ISO 7375/1-1982 (E)

Descriptors : road vehicles, motor vehicles, trailers, pneumatic couplings, pneumatic brake pipes (tubes), dimensions, pipe joints.

Price based on 2 pages

Foreword

ISO (the International Organization for Standardization) is a worldwide federation of national standards institutes (ISO member bodies). The work of developing International Standards is carried out through ISO technical committees. Every member body interested in a subject for which a technical committee has been set up has the right to be represented on that committee. International organizations, governmental and non-governmental, in liaison with ISO, also take part in the work.

Draft International Standards adopted by the technical committees are circulated to the member bodies for approval before their acceptance as International Standards by the ISO Council.

International Standard ISO 7375/1 was developed by Technical Committee ISO/TC 22, *Road vehicles*, and was circulated to the member bodies in January 1981.

It was been approved by the member bodies of the following countries :

ISO 7375-1:1982

Austria	Iran	Poland
Belgium	Italy	Romania
Brazil	Japan	South Africa, Rep. of
Bulgaria	Korea, Dem.P.Rep. of	Sweden
China	Korea, Rep. of	Switzerland
Czechoslovakia	Mexico	United Kingdom
Egypt, Arab Rep. of	Netherlands	USSR
France	New Zealand	

The member body of the following country expressed disapproval of the document on technical grounds :

Germany, F.R.

Road vehicles — Coiled pipe assemblies for pneumatic braking connection between motor vehicles and towed vehicles —

Part 1 : Dimensions

iTeh STANDARD PREVIEW (standards.iteh.ai)

1 Scope

This International Standard specifies for coiled pipe assemblies, the minimum conditions to ensure braking compatibility and in particular response time.

Part 1 specifies the dimensional characteristics of the tubing with its end fitting.

Part 2 specifies the performance requirements.

2 Field of application

This International Standard applies to coiled pipe assemblies connections for vehicle combinations equipped with pneumatic braking systems.

It does not apply to other thermo-plastic tubing used in those braking systems.

Two types are provided :

Type 1 with a working length of 4 m;

Type 2 with a working length of 4,5 m.

3 Reference

ISO 7375/2, *Road vehicles — Coiled pipe assemblies for pneumatic braking connection between motor vehicles and towed vehicles — Part 2 : Performance requirements.*¹⁾

4 Dimensional characteristics

The dimensional characteristics of the coiled pipe assemblies are shown in the figure.

The external design, the method of fixing the pipe to the end fitting as well as auxiliary devices such as anti-kink systems are left to the discretion of the manufacturers.

5 Colour

Black is the recommended colour for the tubing; however coloured sleeving, for example, red, yellow, may be fitted at the ends for line function identification.

1) At present at stage of draft.

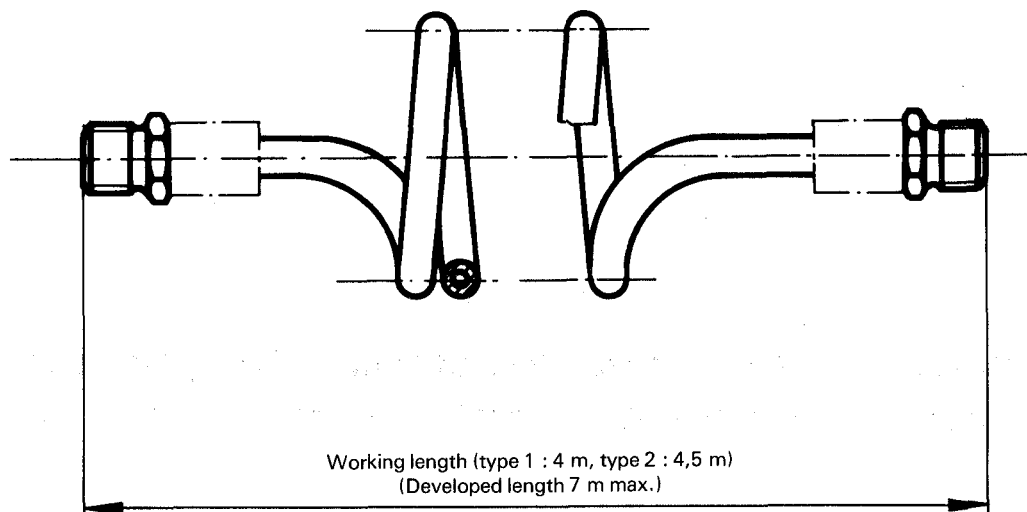

Ovality on diameter of pipe after coiling : $12^{+0,8}_{-1,2}$ mm

Dimensions in millimetres

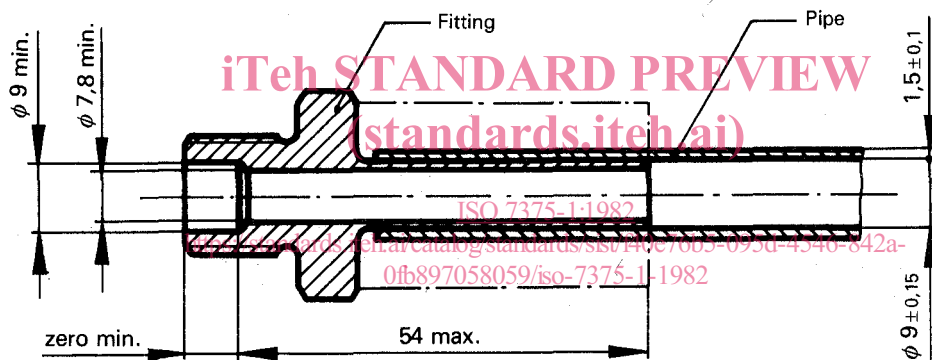

Section through pipe and fitting.

Figure — Coiled pipe assembly

Annex

Bibliography

- ISO 611, *Braking of motor vehicles and their trailers — Terminology.*
- ISO 1726, *Road vehicles — Mechanical coupling between tractors and semi-trailers — Interchangeability.*
- ISO 1728, *Road vehicles — Pneumatic coupling between towing vehicles and trailers — Interchangeability.*
- ISO 4039, *Road vehicles — Pneumatic braking systems — Pipes, tapped holes and male fittings.*