



Standard Guide for Digital Communication Protocols for Computerized Systems¹

This standard is issued under the fixed designation F 1757; the number immediately following the designation indicates the year of original adoption or, in the case of revision, the year of last revision. A number in parentheses indicates the year of last reapproval. A superscript epsilon (ϵ) indicates an editorial change since the last revision or reapproval.

1. Scope

1.1 The principal content of this guide provides a road map to implement a communication network applicable to ship and marine computer systems by:

1.1.1 Examining the relationship of digital communication protocols as a network technological infrastructure,

1.1.2 Outlining the basic building blocks of network topologies and transmission techniques associated with the implementation of transmission media in a network environment; and,

1.1.3 Identifying operating system and environments.

1.2 Using the Open System Interconnection (OSI) model, which provides a layered approach to network functionality and evaluation, common network communications protocols are identified and characterized in this guide according to lower and upper layer protocols corresponding to their degree and type of functionality.

1.3 Although it is desirable that network users, designers, and administrators recognize and understand every possible networking protocol, it is not possible to know the intimate details of every protocol specification. Accordingly, this guide is not intended to address fully every hardware and software protocol ever developed for commercial use, which spans a period of about 25 years. Instead, the user of this guide will be introduced to a brief overview of the majority of past and present protocols which may comprise a ship or marine internetwork, to include Local Area Networks (LANs), Wide Area Networks (WANs), and related hardware and software that provide such network interoperability and data transfer.

1.4 While this guide provides an understanding of the wide range of communication protocols, the user is recommended to consult the reference material for acquiring a more comprehensive understanding of individual communication protocols. However, by examining the basic functions of protocols and reviewing the protocol characterization criteria identified in this guide, the user will be more apt to understanding other protocols not mentioned or addressed herein.

2. Referenced Documents

2.1 ASTM Standards:

¹ This guide is under the jurisdiction of ASTM Committee F-25 on Ships and Marine Technology and is the direct responsibility of Subcommittee F25.05 on Computer Applications.

Current edition approved Nov 10, 1996. Published December 1997.

E 1013 Terminology Relating to Computerized Systems²

2.2 ANSI Standards:

X3T9.5 High Speed Local Network³

X3.139 Fiber Distributed Data Interface (FDDI) – Token Ring Media Access Control (MAC)³

X3.148 Fiber Distributed Data Interface (FDDI)– Token Ring Physical Layer Protocol (PHY)³

X3.166 Fiber Distributed Data Interface (FDDI) – Token Ring Physical Layer Medium Dependent (PMD)³

X3.172 American National Standard Dictionary for Information Systems³

2.3 IEEE Standards:

100 Standard Dictionary for Electrical and Electronic Terms⁴

610 Standard Glossary for Software Engineering Terminology⁴

610.7 Standard Glossary of Computer Networking Terminology⁴

802.1 High Level Interface (Internetworking)⁴

802.2 Logical Link Control⁴

802.3 CSMA/CD Medium Access Control⁴

802.4 Token Bus Medium Access Control⁴

802.5 Token Ring Medium Access Control⁴

802.6 Metropolitan Area Networking⁴

802.8 Fiber Optic Technical Advisory Group⁴

802.9 Local and Metropolitan Area Networks: Integrated Services (IS) LAN Interface at the Medium Access Control (MAC) and Physical (PHY) Layers⁴

803.5

2.4 ISO Standards:

7498 Information Processing Systems–Open Systems Interconnection–Basic Reference Model³

9040/9041 Virtual Terminal (VT)³

8831/8832 Job Transfer and Manipulation (JTM)³

8571/8572 File Transfer Access Management (FTAM)³

9595/9596 Common Management Information Service/Protocol (CMIP)³

8823 Connection Oriented Presentation Protocol³

² Annual Book of ASTM Standards, Vol 14.01.

³ Available from American National Standards Institute, 11 W. 42nd St., 13th Floor, New York, NY 10036.

⁴ Available from IEEE, 445 Hoes Lane, PO Box 1331, Piscataway, NJ 08855-1332.

- 8327 Connection Oriented Session Protocol³
- 8073 Connection Oriented Transport Protocol³
- 8473 Connectionless Network Service³
- 8208 Packet Level Protocol³
- 8802-2 Logical Link Control³
- 9314-2 FDDI³
- 8802-3 CSMA/CD (Bus)³
- 8802-4 Token Bus³
- 8802-5 Token Ring³
- 7776 Link Access Protocol/Link Access Protocol-Balanced (LAP/LAPB)³
- 7809 High-Level Data Link Control (HDLC)³
- 2.5 *ITU Standards:*
- X.25 Packet Level Protocol⁵
- X.226 Connection Oriented Presentation Protocol⁵
- X.225 Connection Oriented Session Protocol⁵
- X.224 Connection Oriented Transport Protocol⁵
- 2.6 *CCITT Standards:*
- V.35
- X.21 (BIS) Interface Between Data Terminal Equipment (DTE) and Data Circuit-Terminating Equipment (DCE) for Synchronous Operation on Public Data Networks
- X.25 Interface Between Data Terminal Equipment (DTE) and Data Circuit Terminating Equipment (DCE) for Terminals Operating in the Packet Mode and Connected Public Data Networks by Dedicated Circuit⁶
- 2.7 *EIA/TIA Standard:*
- 232C
- 568 Commercial Building Telecommunications Wiring Standard (ANSI/EIA/TIA-568-91)⁶
- 2.8 *Internet Request for Comments (RFCs) Standards:*
- RFC 768 User Datagram Protocol (UDP)
- RFC 791 Internet Protocol (IP)⁷
- RFC 792 Internet Control Message Protocol (CMP)
- RFC 793 Transmission Control Protocol (TCP)⁷
- RFC 821 Simple Mail Transfer Protocol (SMTP)⁷
- RFC 826
- RFC 854 TELNET Protocol⁷
- RFC 894
- RFC 903
- RFC 959 File Transfer Protocol (FTP)⁷
- RFC 1042
- RFC 1157 Simple Network Management Protocol
- RFC 1201

3. Terminology

3.1 The terminology used in this guide is defined in Terminology E 1013, IEEE 610, and ANSI X3.172, with the following additions defined in 3.2.

3.2 *Definitions of Terms Specific to This Standard:*

⁵ Available from Electronic Industries Association, 2500 Wilson Blvd., Arlington, VA 22201.

⁶ Available from the U.S. Department of Commerce, National Technical Information Service, 5285 Port Royal Rd., Springfield, VA 22161.

⁷ Documents may be obtained via anonymous ftp from the hosts:ds.internic.net, directory rfc.

3.2.1 *bridge, n*—a device that interconnects local or remote networks no matter what network protocol that is, TCP/IP or IPX, are involved. Bridges form a single logical network.

3.2.2 *hub, n*—a central location for the attachment of cables from nodes and other network components.

3.2.3 *internetwork, n*—a collection of LANs using different network operating systems that are connected to form a larger network.

3.2.4 *LAN (local area network), n*—a data communication system consisting of a collection of interconnected computers, sharing applications, data and peripherals.

3.2.5 *network operating system (NOS), n*—the software for a network that runs in a file server and control access to files and other resources from multiple users.

3.2.6 *node(s), n*—any intelligent device connected to the network. This includes terminal servers, host computers, and any other devices, such as printers and terminals, that are directly connected to the network.

3.2.7 *protocol, n*—a standard method of communicating over a network.

3.2.8 *repeater, n*—a network device that repeats signals from one cable onto one or more other cables, while restoring signal timing and waveforms.

3.2.9 *router, n*—a device capable of filtering/forwarding packets based upon data link layer information.

3.2.10 *server, n*—a device that stores data for network users and provides network access to that data.

3.2.11 *topology, n*—the arrangement of the nodes and connecting hardware that comprises the network.

3.2.12 *WAN (wide area network), n*—a network using common carrier transmission services for transmission of data over a large geographical area.

4. Significance and Use

4.1 This guide is intended to provide an understanding of the wide range of communication protocols standards, allowing the user to understand better their applicability to shipboard networks and marine platform computerized systems. For computerized networks and systems, communication protocols are necessary for integrating various system devices, providing functionality between dissimilar subnetworks, or for enabling remote connections, either pier side or through geophysical communication technologies.

4.2 The wise variety and scope of digital communication protocol standards adds greatly to the complex decision process for specifying compatible protocols for system applications and related devices for the myriad of potential shipboard systems. However, the user must identify the initial networking requirements, so once the network protocols under evaluation are well understood, the decision process should determine the appropriate network protocols. Therefore, this guide is intended to reduce the complexity involved with protocol selection and implementation.

4.3 Network protocols define an agreed, quantifiable entity, or set of rules, by which user computers, system networks, and internetworking devices communicate and exchange information. Communication protocols specify essential networking guidelines, such as physical interface connections, or data format and control operations between two communicating

computers. Ship and marine digital communication protocol requirements are no different than their land-based networked counterparts. Both require standardized protocol selection, in various protocol categories, including LAN standards, WAN protocols, LAN/WAN protocols, network management, wiring hub configurations/operations, hardware platforms, operating systems, and network applications.

5. Origin of Protocol Development

5.1 Communication protocol standards have been developed or refined through three separate processes, identified as follows:

5.1.1 *De facto Protocol Standards*—Acquired widespread use of a popular technique adopted by vendors and developers;

5.1.2 *De jure Protocol Standards*—Standards making bodies; and,

5.1.3 *Proprietary Protocol Standard*—Private corporation-based protocols with limited interoperability.

5.2 The open standards approach is now the norm, which allows multiple protocol networking solutions to be available, and as a result, proprietary protocols are now becoming obsolete.

6. Local Network Interconnection

6.1 The characteristic of a local network is determined primarily by three factors: transmission medium, topology, and medium access control protocol.

6.1.1 The principal technological elements that determine the nature of a local network are the topology and transmission medium of the network. Together, it determines the type of data that may be transmitted, the speed and efficiency of communications, and the type of applications that a network may support.

6.1.2 Interconnecting a set of local networks is referred to as an internetworking. The local networks are interconnected by devices generically called gateways. Gateways provide a communication path so that data can be exchanged between networks.

6.2 *Topology*—The common topologies used for local networks are star, ring, and bus/tree (see Fig. 1).

6.2.1 *Star Topology*—In a star topology, a central switching element is used to connect all the nodes in the network. The central element uses circuit switching to establish a dedicated path between two stations wishing to communicate (see Fig. 1).

6.2.2 *Ring Topology*—The ring topology consists of a closed loop, with each node attached to a repeating element. Data circulate around the ring on a series of point-to-point data links between repeaters. A station wishing to transmit waits for its next turn and then sends data out onto the ring in the form of a packet (see Fig. 1).

6.2.3 *Bus/Tree Topology*—The bus or tree topology is characterized by the use of a multipoint medium. The bus is simply a special case of the tree, in which there is only one trunk, with no branches. Because all devices share a common communications medium, only one pair of devices on a bus or tree can communicate at a time. A distributed medium access protocol is used to determine which station may transmit (see Fig. 1).

6.3 *Internetwork Topology*—The common topologies used to support emerging networking topologies requiring the integration of data, video and voice, as well as higher transport bandwidth are backbone, hierarchical, and mesh (see Fig. 2).

6.3.1 *Backbone*—Backbone configurations are used in networking environments in which local networks are connected over high-speed backbone cables. Bridges and routers are used to manage the data passing between interconnected networks and the backbone (see Fig. 2).

6.3.2 *Hierarchical*—In the hierarchical configuration, star-configured hubs are wired to a central hub that handles interhub traffic. Routers and Asynchronous Transfer Mode (ATM) technology provide support to traffic intensive network applications requiring the integration of voice, video, and data (see Fig. 2).

6.3.3 *Mesh*—In mesh configurations, there are at least two pathways to each node. This is a common configuration in emerging high-speed enterprise networks requiring the integration of voice, video, and data. It is composed of internetworking devices, such as bridges, routers, and ATM technology. The internetworking devices provide efficient paths for data to travel from one point to another in this configuration. Mesh networks often are used because of reliability; when one path goes down, another can take over (see Fig. 2).

6.4 *Cabling*—Cabling falls into the following categories: coax, twisted pair, and fiber.

6.4.1 *Coax*:

6.4.1.1 *Thicknet*—The standard Thicknet is IEEE 802.3 10BASE5. It is a 0.4-in. diameter RG 4 50-Ω coaxial cable. It may be up to 500 m in length. A maximum of 100 devices can be attached to this cable.

6.4.1.2 *ThinNet*—The standard for ThinNet is IEEE 802.3 10BASE2. It is a 0.25-in. diameter RG58A/U 50-Ω coaxial cable. It can be up to 185 m in length and have a maximum of 30 devices attached to it. Each device normally is attached at 0.5-m increments via a BNC T-connector. However, devices may be attached to an AUI cable and external transceiver.

6.4.2 *Twisted Pair*:

6.4.2.1 The standard for twisted pair is EIA/TIA-568. It is a 24-AWG telephone wire. The ends of the twisted pair wires are composed of RJ-45 or RJ-11 telephone-style connectors. Each

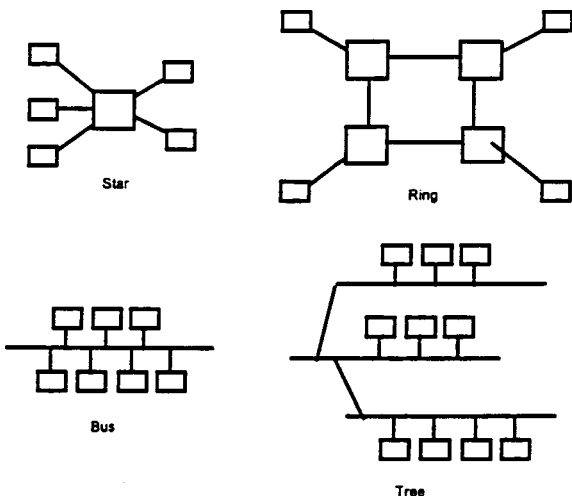

FIG. 1 Local Network Topologies

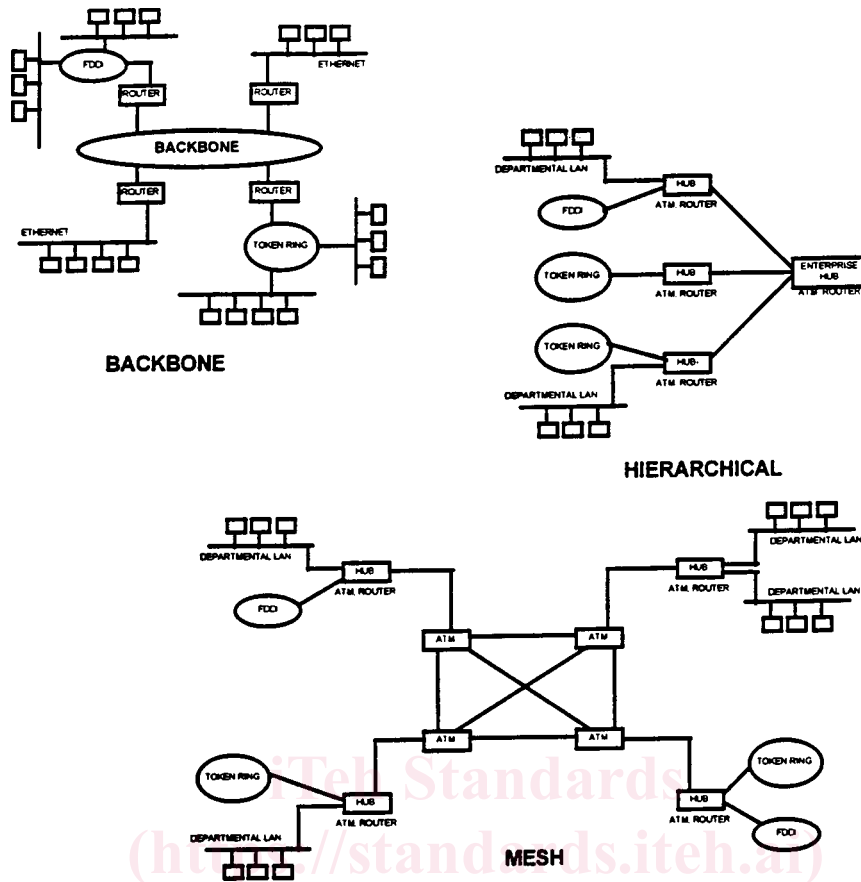

FIG. 2 Internetwork Topology

device connects to a network wiring hub which controls or passes the network signal. There are five category ratings for twisted pair wiring, LVL/CAT-1 through LVL/CAT-5.

6.4.2.2 There are two major types of twisted pair: unshielded twisted pair (UTP) and shielded twisted pair (STP). Environmental surroundings dictate what type of twisted pair is used. If the environment is prone to a high degree of electrical interference, STP is used.

6.4.3 *Optical Fiber*—See Table 1.

6.5 Table 2 provides a generalized comparison of the advantages and disadvantages of the technical characteristics of local networks, using the transmission medium as a frame of reference.

Service Classes of Local Networks and Bandwidth Networks—Computer networks that serve as components of a communication network provide support to a large multitude of service classes (see Table 3).

6.5.1 *Local Area Network (LAN)*—The LAN provides services to support a group of interconnected computers to share applications, data, and peripherals. Bandwidth service is from 1 to 10 Mbps.

6.5.2 *High-Speed Local Area Networks (HSLN)*—The HSLN provides a service in the range of 50 Mbps to 1 Gbps.

There are two key applications for HSLN: backend and backbone networks. A backend HSLN main function is to provide high end-to-end throughput between high-speed devices, such as servers and mass storage devices. A backbone HSLN provides a LAN or WAN that interconnects intermediate systems. Fiber optic cables are used as a transmission medium to internetwork topologies.

6.5.3 *Wide Area Network (WAN)*—A network that covers a large geographic area. The differences between WAN and LANs are as follows:

6.5.3.1 *Economic*—WAN services are purchased; LANs are owned.

6.5.3.2 *Technical*—WANs are made up of point-to-point links; LANs are shared-media.

6.6 *Medium Access Control Protocol*—To facilitate the sharing of the transmission among network stations, a proper medium access control scheme must be implemented to control, coordinate, and supervise the access of user information to and from the shared transmission medium:

6.6.1 *LAN*—IEEE 802.3, IEEE 802.4, and IEEE 802.5 (CSMA/CD, token bus, and token ring) LAN protocols.

6.6.2 *HSLN*—IEEE 802.2 (FDDI fiber token ring protocol) or IEEE 802.6 DQDB, ATM.

6.6.3 *WAN*—X.25 Frame Relay, ATM.

6.7 *Internetworking (Gateways and Routers)*—Internetworking is the interconnection and interoperability of small-size local networks into existing networks. A local

TABLE 1 Optical Fiber Cabling

Type	Light Source	Bandwidth	Primary Application
Single mode	laser	100 GHz	telephone traffic
Multimode	LED	1-2 GHz	data traffic

TABLE 2 Technical Characteristics of LANS

Characteristic	Transmission Medium			
	twisted pair (UTP, STP)	baseband coaxial cable	broadband coaxial cable	fiber optic cable
Topology	bus, star, or ring	bus or ring	bus or ring	bus, star, or ring
Channels	single channel	single channel	multichannel	single, multichannel
Data rate	normally up to 4 Mbps or 16 Mbps; up to 100 Mbps obtainable	normally 2 to 10 Mbps; up to 100 Mbps obtainable	up to 400 Mbps	up to 1 Gbps
Maximum nodes on net	usually <255	usually <1024	several thousands	several thousands
Major advantages	low cost; may be able to use existing wire	low cost; simple to install	supports voice, data, and video applications simultaneously	supports voice, data, and video applications simultaneously
Major disadvantages	limited bandwidth, requires conduits; low immunity to noise	low immunity to noise	high cost; difficult to install; requires RF modems	cable cost; difficult to splice

TABLE 3 Classes of Local Networks

	Local Area Network	High-Speed Local Network	WAN
Transmission medium	twisted pair, coax, fiber	twisted pair, CATV, coax, fiber	public/private data network providers
Topology	bus, tree, ring	backbone, hierarchical, mesh	point-to-point
Transmission speed	1-20 Mbps	50 Mbps - 1 Gbps	56 Kbps - 45.5 Mbps
Switching technique	packet, circuit	packet, circuit	packet, circuit

network should have the capability to support multiple protocols and allow difference environments to operate in parallel. Internetworking devices available for these services are Routers and Gateways.

6.7.1 Routers are devices that implement the network service. Routers are required to support multiple protocol stacks, each with its own routing protocols, and to allow these different environments to operate in parallel.

6.7.2 Gateways are applications specific that connect different architectures. It also provides translation services between different protocols.

6.8 *Types of LANs*—LANs are descriptive in their configuration at two levels: administrative relationship between nodes (stations) and physical and logical relationship among nodes.

6.8.1 *Administrative Relationship Between Nodes (Station)*—LANs are divided into server-based and peer-to-peer LANs. Server-based LAN (client server) controls access to some resource, such as a hard disk or printer, and serves as a hosts for the workstations connected to the server. A workstation request services, such as access to fields or programs on the hard disk or use of a printer, from a server.

6.8.1.1 Servers run the network operating system (NOS) software; workstations run client software that manages the communication between the workstation and the network.

6.8.1.2 Peer-to-peer LANs involve direct communications between computing devices without a dedicated server.

6.8.2 *Physical and Logical Relationship Among Nodes*—This has to do with the manner in how data is transmitted over a network. The physical is concerned with the topology, that is, bus, ring, or star, and logical refers to the method of data transport that is Ethernet, Token Ring, FDDI, ATM, and so forth.

6.9 *Network Operating System (NOS)*—The NOS runs on a server and is responsible for processing requests from work-

stations, for maintaining the network, and for controlling the services and devices available to users. An NOS may replace the native operating system or run as a program on top of the native operating system. Current NOS available are: NOVELL Netware, WINDOWS NT, LANtastic, BANYAN, IBM LAN Server, LAN Manager, AppleShare/AppleTalk.

6.10 *Operating System (OS)*—Operating systems bring together disparate computing resources and present the user with more convenient abstractions. These resources include devices for processing, storing, and transmitting information:

6.10.1 *DOS (Disk Operating System)*—Single-user operating system for the personal computer (PC).

6.10.2 *Windows 95/NT*—Microsoft windows product replacing Windows 3.1 and Windows for Workgroup 3.11. It provides system monitor utilities, remote access, network e-mail, fax capabilities, and file-and printer-sharing for both Windows-based and Netware-based clients.

6.10.3 *OS/2*—A multicasting operating system originally developed by IBM and Microsoft for use with Intel's micro-processor and IBM's Personal System/2 (PS/2) computers.

6.10.4 *MAC OS*—Apple's Mac operating system.

6.10.5 *UNIX*—A multitasking, multiuser operating system developed by AT&T. This means that more than one user can use the same computer (programs, file system, memory, CPU) by logging in off of different ports (serial, Ethernet, Internet, and so forth).

6.11 *Operating Environments*—Operating environments provide computing flexibility and power to have more than one application active at the same time. They allow users to activate and switch several applications simultaneously.

6.11.1 *Windows 3.1*—This program provides an environment for running 16-bit Windows and DOS applications. It also supports multimedia, true-type fonts, compound documents (OLE), as well as drag-and-stop capabilities.

6.11.2 *Windows for Workgroups*—This program is a LAN-capable version of MS Windows 3.1 environment providing integrated file sharing, electronic mail (Microsoft Mail), and workgroup scheduling (Schedule +) capabilities. Windows for Workgroups 3.11 also supports 32-bit disk and file access.

6.11.3 *Windows 95/NT*—This program provides utilities, protocols, and services for a LAN environment running client software with support for Windows, Windows NT Workstation, Windows for Workgroups, MS-DOS, Macintosh, OS/2, and UNIX.

6.11.4 *X Window System*—A network-based windowing system. It provides an application interface for graphic window displays.

7. OSI Layers of Functionality

7.1 The OSI is a reference model put forth by the International Standards Organization (ISO) for communication between computer equipment and networks partitions computer communication functions into seven layers. Each layer provides a certain kind of service to the next higher layer. This service is provided by communicating with the peer entity in same layer of the remote host using the service provided by the next lower layer. This model explains what each layer does. The model is often used to explain a suite of protocols, not just OSI, to allow computers to share resources across a network (see Table 4).

7.2 The content of each of the first four layers is dictated by the parameters of the network technology, and the upper three by the demands of the application user. As shown in Fig. 3, the lowest four layers, which are physical (1), data link (2), network (3), and transport (4), correspond roughly to protocols used in all networks. Physical distinguishes individual (0,1) bits, data link allows reliable transmission of groups of bits between adjacent computers, network provides safe routing data packets between distant source and destination computers, and transport lets programs running on different computers exchange sequences of possibly long messages.

7.3 The bottom three layers are implemented by communications carrier hardware or by LAN interfaces. Transport software runs on user computers. The highest three layers, session (5), presentation (6), and application (7), are intended to serve the needs of the application or application-specific elements.

7.4 For WANs, the intermediate-node routing function, network layer, is important, but media access is simple, usually a matter of making a leased, dial-up connection or satellite. Conversely, for LANs and MANs, no routing decisions need be made, and the network layer is essentially absent, although the multiaccess protocol can become quite sophisticated.

8. Layers of Interconnection

8.1 The OSI model allows networks to be interconnected at Layers 1 through 3 and 7. Interconnections between LANs and WANs usually occur at Layers 2 through 4 except for protocol conversion between specific applications, such as electronic mail which occur at Layer 7. A generic LAN/WAN interconnection function must operate at the lower OSI layers.

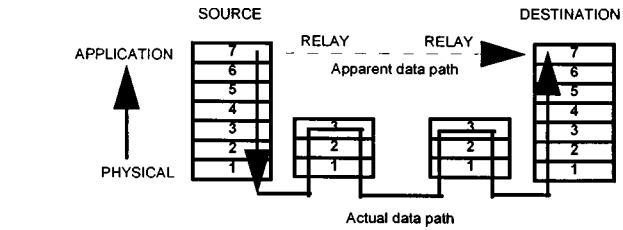

FIG. 3 Protocol Layers in the OSI Model

8.2 *Model Structure*—The OSI presents an abstract reference model to describe the computer communications. A layering techniques is used to divide the functions in to distinct yet connected layers. The seven layers can be partitioned into two main infrastructures, the lowest three layers provide internetworking services and the upper four layers are the users of these services. The upper layers, together, provide common network application services. One of the layers, the Transport Layer (4), serves as the boundary between the network-specific elements and the application-specific elements (see Fig. 4):

8.2.1 Lower layer infrastructure providing the end-to-end services responsible for data transfer.

8.2.2 Upper layer infrastructure providing the application services responsible for information transfer.

8.2.3 Each layer provides a well-defined function. Conceptually, these layers can be considered as performing one of two functions:

8.2.3.1 *Network-Dependent Functions*, lower layer.

8.2.3.2 *Application-Oriented Functions*, upper layer.

8.2.4 Thus when interconnecting networks, communication services are characterized by the following:

8.2.4.1 *Data Link Protocol*—Ethernet, Token Ring, FDDI, and ATM.

8.2.4.2 *Network Protocol*—IP, IPX, TCP, IPVINES, NETBIOS, and NETBEUL.

8.2.4.3 *Higher Level Protocol (NOS)*—Netware, Appletalk, Banyan VINES, Windows NT, IBM OS/2 LAN Manager, and so forth.

8.2.5 A canonical form of a layered communication protocol is illustrated in Fig. 5.

9. Protocol Characterization—Upper Versus Lower Layer Protocols

9.1 The characterization of common network protocols based on the layers of the OSI reference model provides a comparative technique to separate the various communication protocols into two categories. This perspective characterizes communication protocols based on their functionality and

TABLE 4 OSI Layers of Functionality

Layer	Name	Function
7	Application	Provides end-user services, such as application layer file transfers, electronic messages, virtual terminal emulation, remote database access, and network management. The end user interacts with the application user.
6	Presentation	Provides for the representation of information that is communicated between or referred to by application processes.
5	Session	Provides the means to organize and synchronize the dialog between application processes and manage their data.
4	Transport	Provides the transparent transfer of data between systems.
3	Network	Provides routing and relaying through immediate system. In intermediate systems in which there is no application program involved in the communication, the packets are only processed by the lower three layers.
2	Data link	Provides for the transfer of data between directly connected systems and detects any errors in the transfer.
1	Physical	Provides the transparent transmission of bit streams between systems including relaying through different media.