

INTERNATIONAL STANDARD

ISO
7400

Second edition
1990-11-01

Mopeds — Alternating current flasher units

Cyclomoteurs — Centrales clignotantes en courant alternatif

iTeh STANDARD PREVIEW
(standards.iteh.ai)

ISO 7400:1990

<https://standards.iteh.ai/catalog/standards/sist/1ada1779-52a-4875-91fd-2e0f0a6458b8/iso-7400-1990>



Reference number
ISO 7400:1990(E)

Foreword

ISO (the International Organization for Standardization) is a worldwide federation of national standards bodies (ISO member bodies). The work of preparing International Standards is normally carried out through ISO technical committees. Each member body interested in a subject for which a technical committee has been established has the right to be represented on that committee. International organizations, governmental and non-governmental, in liaison with ISO, also take part in the work. ISO collaborates closely with the International Electrotechnical Commission (IEC) on all matters of electrotechnical standardization.

Draft International Standards adopted by the technical committees are circulated to the member bodies for voting. Publication as an International Standard requires approval by at least 75 % of the member bodies casting a vote.

International Standard ISO 7400 was prepared by Technical Committee ISO/TC 22, *Road vehicles*.

This second edition cancels and replaces the first edition (ISO 7400:1984), of which it constitutes a minor revision.

This International Standard forms one of a series of related Standards:

ISO 7398, *Motorcycles — Direct current flasher units*

ISO 7399, *Motorcycles — Alternating current flasher units*

ISO 7400, *Mopeds — Alternating current flasher units*

ISO 8052, *Mopeds — Direct current flasher units*

© ISO 1990

All rights reserved. No part of this publication may be reproduced or utilized in any form or by any means, electronic or mechanical, including photocopying and microfilm, without permission in writing from the publisher.

International Organization for Standardization
Case Postale 56 • CH-1211 Genève 20 • Switzerland

Printed in Switzerland

Mopeds — Alternating current flasher units

1 Scope

This International Standard specifies the electrical characteristics with which alternating current (a.c.) flasher units for mopeds are required to comply when submitted for type-testing.

It applies to flashers, operating simultaneously or alternately¹⁾ intended for use on mopeds, as defined in ISO 3833, with 6 V or 12 V electrical systems.

2 Normative references

The following standards contain provisions which, through reference in this text, constitute provisions of this International Standard. At the time of publication, the editions indicated were valid. All standards are subject to revision, and parties to agreements based on this International Standard are encouraged to investigate the possibility of applying the most recent editions of the standards indicated below. Members of IEC and ISO maintain registers of currently valid International Standards.

ISO 3833:1977, *Road vehicles — Types — Terms and definitions*.

IEC 810:1986, *Lamps for road vehicles — Performance requirements*.

IEC 810:1986 / Amd.1:1988, Amendment 1.

3 Identification

Each flasher unit shall show, legibly and indelibly, the trade-name or -mark of the manufacturer, the rated voltage, the symbol ~, the short-circuit current I_{cc} and the identification numbers of the terminals in accordance with table 1 and the wattages of the lamps for which the flasher is designed.

Table 1 — Identification of flasher unit terminal

Identification number of terminals ¹⁾	Allocation
1	Current supply
2	To the turn signal switch
3	To the turn signal switch (unit flashing alternately)
4	Common return
5	To the tell-tale lamp
7	"Off" circuit of the operating tell-tale
8	Return for the turn signal switch, left side
9	Return for the turn signal switch, right side
10 ²⁾	Indicator lights to the left
11 ²⁾	Indicator lights to the right

1) Other terminal identifications are allowed.
2) When front and rear direction indicator lights of a moped are individually connected to the flasher, the corresponding terminals shall each have the same identification number.

4 Electrical characteristics

4.1 Working voltage

The working voltage is the voltage existing between points D₁ (or D₂ or D₃) and E of the test circuit (see figure 1 and figure 2), in accordance with 4.4, with the flasher short-circuited.

Tests shall be performed with alternating current of frequency 50 Hz or 60 Hz at working voltages of 4,5 V to 5,5 V and 7,5 V r.m.s. for 6 V systems and 9 V to 11 V and 15 V r.m.s. for 12 V systems.

1) Direction indicator lights on the same side of the vehicle flash alternately.

4.2 General test conditions

If not otherwise specified, the flasher shall be tested in a room at an ambient temperature of $23\text{ }^{\circ}\text{C} \pm 5\text{ }^{\circ}\text{C}$.

The flashers shall be tested in the position (or positions) indicated by the manufacturer.

4.3 Test circuitry and equipment

4.3.1 Wiring diagram

The resistances in the circuitry shall have the values indicated in the wiring diagram shown in figure 1 or figure 2, for simultaneous or alternate flashing respectively. The resistance of the cables and the ammeter are included in the resistances indicated in these wiring diagrams. To check these resistances, the flasher and the filament lamps shall be short-circuited by shunts not exceeding $0,005\ \Omega$ each.

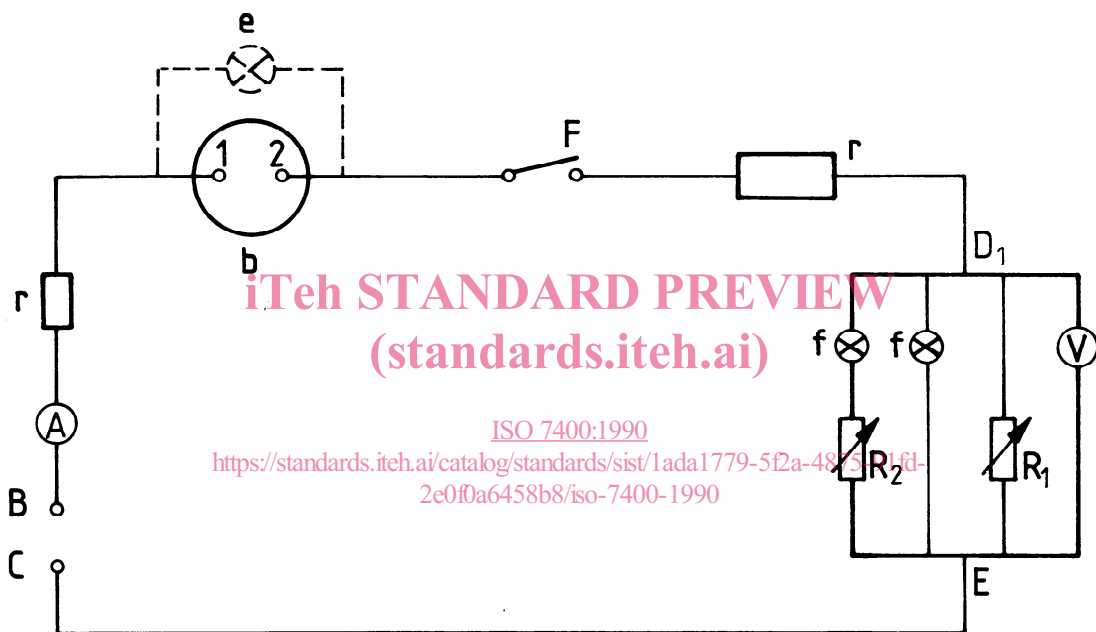

b = flasher unit

e = tell-tale lamp

f = main lamps

F = switch

R_1, R_2 = trimming resistors

$r = 0,1\ \Omega \pm 0,01\ \Omega$

Figure 1 — Wiring diagram to test flashers operating simultaneously

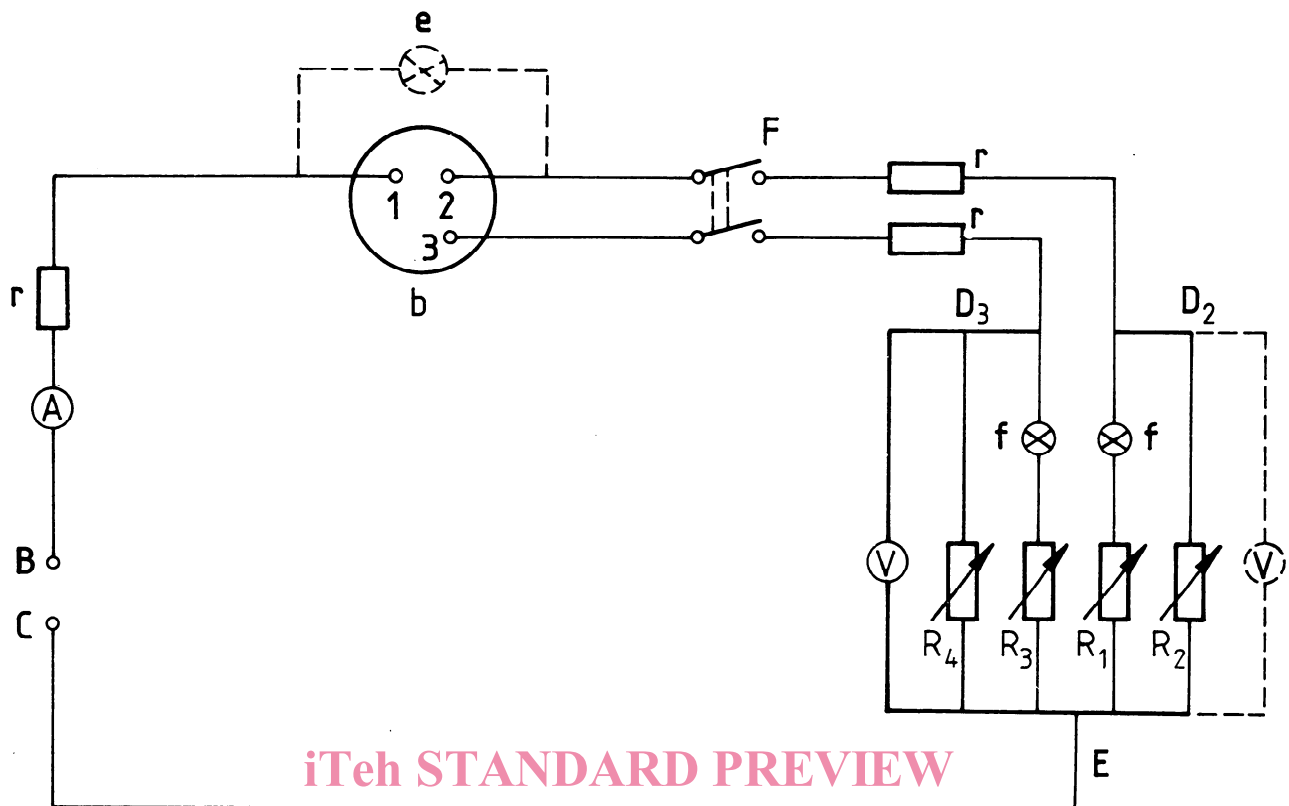

b = flasher unit

F = switch

e = tell-tale lamp

ISO 7400:1990

R₁, R₂, R₃, R₄ = trimming resistors

f = main lamps

r = 0,1 Ω ± 0,01 Ω

Figure 2 — Wiring diagram to test flashers operating alternately

4.3.2 Filament lamps

Only filament lamps in accordance with IEC 810 shall be used. This does not apply to tell-tale lamps when they are not connected in parallel to the main lamps.

4.3.3 Measuring equipment

The equipment used to measure the flash-rate, the "on"-time, the starting time and voltage drop in the flasher shall not disturb the circuit. The measuring equipment shall be able to measure the r.m.s. voltage.

4.3.4 Power supply characteristics

For the tests a power transformer of power at least ten times greater than that supplied during the most exacting test shall be used. It shall supply the voltage as in 4.1 with a tolerance ± 2 %.

4.4 Adjustments

4.4.1 The voltage at the terminals D₁ (or D₂ or D₃) and E (see figure 1 and figure 2) of the filament lamps shall be adjusted to 6,75 V or 13,5 V after the flasher has been short-circuited by a shunt in accordance with 4.3.1.

The lamps used for the tests shall be selected so that, before the following adjustment, the sum of the wattages does not deviate by more than + 2 % and - 6 % from the sum of the corresponding mean wattage values at 6,75 V or 13,5 V.

The current to obtain the required electrical load shall be adjusted, exact to 0,5 %, to the sum of the corresponding mean wattage values at test voltage, by adjusting one of the trimming resistors R₁ or R₂, and R₃ or R₄, with the other(s) neutralized. The filament lamps of the tell-tales shall also be included when they are connected in parallel to the main lamps.

For the tests, the power supply shall be so adjusted as to obtain the voltages specified at the terminals D₁ (or D₂ or D₃) and E at the different test temperatures, without re-adjustment of the trimming resistors R₁, R₂, R₃ or R₄.

4.4.2 Where an operating tell-tale is fitted, it shall be connected in the test circuit as indicated by the manufacturer.

5 Test procedure

5.1 Starting time

5.1.1 By convention, the following terms apply:

- **beginning of the current "on"-time:** the moment when the working voltage reaches 3,5 V, 4,5 V and 6 V or 7 V, 9 V and 12 V.
- **beginning of the current "off"-time:** the moment when the working voltage reaches 1 V, 1,5 V and 2 V or 2 V, 3 V and 4 V.

5.1.2 The beginning of the first current "on"-time shall be not more than 1 s after switching on at point F.

5.1.3 The period of time for the first current "on"-time shall be at least 0,2 s.

5.1.4 The beginning of the first current "off"-time shall be not more than 1,5 s after switching on at point F.

5.1.5 The requirements of 5.1.2, 5.1.3 and 5.1.4 shall be complied with at the working voltages specified in 4.1.

5.1.6 The requirements of 5.1.2, 5.1.3 and 5.1.4 shall be complied with on the basis of an average of three starts, separated by cooling intervals of at least 5 min.

5.1.7 In the case of systems operating alternately, the conditions of 5.1.2, 5.1.3 and 5.1.4 shall be complied with for each direction indicator light on the same side of the vehicle.

5.2 Flash-rate and current "on"-time

5.2.1 Flash-rate

For electrical loads intended by the manufacturer, the flash-rate shall comply with the requirements of table 2 when, after at least five consecutive cycles, the mean value of at least three consecutive cycles is determined.

Table 2 — Flash-rate for flashers

Working voltage		Stabilized temperature	Flash-rate
V		°C	cycles/min
5,5	11	- 18 ± 2,5	60 to 120
7,5	15	23 ± 5	
4,5	9	52 ± 2,5	45 to 120

Measurements shall be taken after 2 h of stabilization at the specified temperatures. The time of operation at the temperature of - 18 °C shall not exceed 15 s. At the temperature of 52 °C, measurements shall be taken after 5 min ± 1 min of continuous operation.

5.2.2 Current "on"-time

The current "on"-time (cyclic ratio: ratio, as a percentage, of the current "on"-time over one cycle) shall be measured, after at least five consecutive cycles, by determining the mean value of at least three consecutive cycles under the conditions of temperature and voltage defined in 5.2.1.

Under these conditions, the current "on"-time shall remain between 40 % and 60 %.

5.3 Operating tell-tales

5.3.1 Normal conditions (all lamps operating)

When all lamps are operating normally, the audible and/or optical operating tell-tales (if any) shall operate, at the rate of the main filament lamps, in phase or counterphase, at temperatures of - 18 °C ± 2,5 °C, 23 °C ± 5 °C and 52 °C ± 2,5 °C.

This test shall be carried out in accordance with 4.4 but without re-adjustment of trimming resistors R₁ or R₂, and R₃ or R₄.

5.3.2 Indication of filament lamp failure

In the case of a failure of a main filament lamp at temperatures of - 18 °C ± 2,5 °C, 23 °C ± 5 °C and 52 °C ± 2,5 °C the audible and/or optical operating tell-tales (if any) shall indicate this failure either by ceasing to function, or by a change of frequency.

In the case of a tell-tale lamp, it is considered that it ceases to function when it remains either constantly extinguished or lit.

The unaffected main filament lamp shall either remain lit or continue to flash, in which case a change

in frequency is required except if the flasher unit is designed to function with a tell-tale.

This test shall be carried out in accordance with 4.4 but without re-adjustment of trimming resistors R_1 or R_2 , and R_3 or R_4 .

5.4 Voltage drop

Measurements shall be carried out after at least five complete functioning cycles.

At the voltage shown in table 2 and with the charge selected and regulated as in 4.4, voltage drops between the input and output terminals considered shall not exceed 0,8 V.r.m.s.

5.5 Dielectric strength

When new and in an ambient air relative humidity of 45 % to 75 %, the flasher shall be capable of withstanding for 1 min a voltage of 1000 V r.m.s. with a frequency of 50 Hz or 60 Hz between the terminals and the exterior metallic parts (mounting brackets, housing, rivets), if these parts are not electrically connected to one of the terminals.

This test is not required where such exterior metallic parts do not exist or if an electrical connection exists as stated above.

5.6 Overload strength

Before the test, the flasher terminals considered shall be shunted by 5 m Ω max. With the resistor R_3 , the current shall be adjusted to I_{cc} (see figure 3). The shunt shall then be removed for the test.

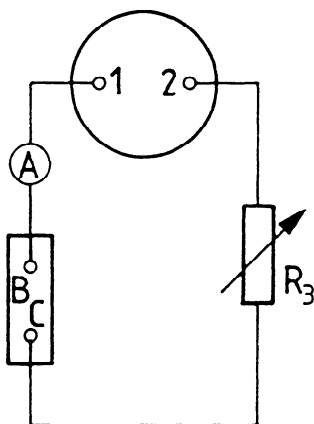

Figure 3 — Wiring diagram for overload strength test

With a voltage of 6,5 V or 13 V, the flasher shall be capable of resisting the maximum I_{cc} current on the flasher label once only for 10 s between the input and output terminals considered, with the exception of tell-tale circuits.

The value of I_{cc} is defined as follows:

$$I_{cc} \geq \frac{P}{U} \times 1,5$$

where

P is the lamp wattage;

U is the nominal voltage.

5.7 Vibration test

The flasher shall be mounted on a test bench in the position and with the mounting method corresponding to that on the vehicle. The test shall be carried out at an ambient temperature of 23 °C \pm 5 °C.

5.7.1 Checking

With sinusoidal vibrations between 20 Hz and 200 Hz, with an acceleration amplitude of 50 m/s², the flash-rates of the main filament lamps shall comply with the specifications of 5.2.1. However, this test is only required at a temperature of 23 °C \pm 5 °C. The operating tell-tales shall also still continue to function. Momentary frequency variations with respect to the main filament lamps are, however, allowed.

This test shall be carried out successively in each of the three main axes.

5.7.2 Vibration endurance

The flasher, not connected to the power supply, shall be subjected to sinusoidal vibrations varying from 20 Hz to 200 Hz and back with a frequency variation of 2 octaves/min and with an acceleration amplitude of 50 m/s².

After 45 h of test, equally divided between the three main axes, the flasher shall not have deteriorated and shall still comply with the conditions specified in 5.1 and 5.2. The tell-tales shall also still continue to function.

5.8 Impact test

5.8.1 Test conditions

At an ambient temperature of 23 °C \pm 5 °C, the flasher shall be suspended at the end of a wire of 500 mm length, the other end of which shall be fixed. The fixing point shall be in the plane of a vertical face of a steel block of mass 25 kg. The wire shall be moved to make an angle of 60° with the vertical

in a plane perpendicular to the corresponding steel block surface. The flasher shall then be released to strike the block.

This test shall be carried out in both directions of each of the three main axes. One test only shall be conducted on each sample.

Any other equivalent method may be accepted.

5.8.2 Test requirements

After at least 3 min operating, the flashers tested shall comply with the requirements of 5.1, 5.2 and 5.3 at the temperature of $23\text{ °C} \pm 5\text{ °C}$. The frequency shall not vary, because of the impact, by more than 12 cycles/min.

However, if the variation is more than 12 cycles/min, the impact test shall be repeated five times, after which it is sufficient that the flashers tested comply with the requirements of 5.2.1 at a temperature of $23\text{ °C} \pm 5\text{ °C}$.

5.9 Resistance to heat and cold

The flasher shall withstand:

- a) a temperature of $+40\text{ °C} \pm 3\text{ °C}$, at a relative humidity of 90 % to 95 % for 48 h;
- b) a temperature of $+80\text{ °C} \pm 3\text{ °C}$ for 1 h;
- c) a temperature of $-40\text{ °C} \pm 3\text{ °C}$ for 3 h.

These tests shall be conducted with no electrical connection.

At the end of each of these three tests, which are not cumulative, and after reaching an ambient temperature of $23\text{ °C} \pm 5\text{ °C}$, the flasher shall meet the

requirements of the tests specified in 5.1, 5.2, 5.3 and 5.4.

5.10 Endurance

The flasher shall be connected as indicated in 4.3, but without trimming resistors.

5.10.1 Test conditions

The circuit shall be supplied with 7 V or 14 V (measured at the terminals of the power supply) and flashers shall be subjected to the following tests, but one of the tests only is to be conducted on each sample:

- a) 100 h of working cycles consisting of 15 s "on" and 15 s "off";
- b) 50 h of continuous operation.

5.10.2 Test requirements

After a minimum rest time of 1 h, the flasher shall meet the requirements of the tests specified in 5.1, 5.2 and 5.3.

Two out of eight samples tested in accordance with 5.4 shall, however, be allowed to exceed the maximum voltage drop specified in 5.4 by a margin of 20 %.

6 Number of samples and sequence of individual tests

The number of samples shall be 20.

Initially, all samples shall comply with the specifications of 5.1 to 5.4. Subsequently the tests on the samples shall be carried out in accordance with 5.5 to 5.10, as shown in table 3.

Table 3 — Individual tests

Test No.	1	2	3	4	5	6	
Sample No.	Dielectric strength (see 5.5)	Overload strength (see 5.6)	Resistance to cold and heat (see 5.9)	Impact (see 5.8)	Vibration (see 5.7)	Endurance (see 5.10)	
						100 h	50 h
1	X	X					
2	X	X					
3			X	X			
4			X	X			
5			X	X			
6			X	X			
7			X	X			
8			X	X			
9					X		
10					X		
11					X		
12					X		
13						X	
14						X	
15						X	
16						X	
17							X
18							X
19							X
20							X

iTeh STANDARD PREVIEW
(standards.iteh.ai)

ISO 7400:1990

<https://standards.iteh.ai/catalog/standards/sist/1ada1779-5f2a-4875-91fd-2e0f0a6458b8/iso-7400-1990>