



SLOVENSKI STANDARD
SIST ISO 7416:1996

01-april-1996

C_fc[`YdcgbYH`dcX`cý_YždcVc`ýUbYžnUj]U YbY`nj YnY`j Y]_YlfXbcgh]j `Y_`Yb]`
_cbgfi _WUA

Plain washers, chamfered, hardened and tempered for high-strength structural bolting

Rondelles plates chanfreinées trempées et revenues pour vis à serrage contrôlé pour constructions métalliques

STANDARD PREVIEW
(standards.iteh.ai)

Ta slovenski standard je istoveten z: **ISO 7416:1984**

SIST ISO 7416:1996
<https://standards.iteh.ai/catalog/standards/sist/e710bed2-412d-4140-81a0-9a01a429b451/sist-iso-7416-1996>

ICS:

21.060.30 Podložke, varovalni elementi Washers, locking elements

SIST ISO 7416:1996

en

iTeh STANDARD PREVIEW
(standards.iteh.ai)

SIST ISO 7416:1996

<https://standards.iteh.ai/catalog/standards/sist/e710bed2-412d-4140-81a0-9a01a429b451/sist-iso-7416-1996>

International Standard



7416

INTERNATIONAL ORGANIZATION FOR STANDARDIZATION • МЕЖДУНАРОДНАЯ ОРГАНИЗАЦИЯ ПО СТАНДАРТИЗАЦИИ • ORGANISATION INTERNATIONALE DE NORMALISATION

Plain washers, chamfered, hardened and tempered for high-strength structural bolting

Rondelles plates chanfreinées trempées et revenues pour vis à serrage contrôlé pour constructions métalliques

First edition — 1984-11-15

iTeh STANDARD PREVIEW
(standards.iteh.ai)

[SIST ISO 7416:1996](#)

<https://standards.iteh.ai/catalog/standards/sist/e710bed2-412d-4140-81a0-9a01a429b451/sist-iso-7416-1996>

UDC 621.882.4

Ref. No. ISO 7416-1984 (E)

Descriptors : fasteners, washers, plain washers, specifications, dimensions, designation, marking.

Foreword

ISO (the International Organization for Standardization) is a worldwide federation of national standards bodies (ISO member bodies). The work of preparing International Standards is normally carried out through ISO technical committees. Each member body interested in a subject for which a technical committee has been established has the right to be represented on that committee. International organizations, governmental and non-governmental, in liaison with ISO, also take part in the work.

Draft International Standards adopted by the technical committees are circulated to the member bodies for approval before their acceptance as International Standards by the ISO Council. They are approved in accordance with ISO procedures requiring at least 75 % approval by the member bodies voting.

International Standard ISO 7416 was prepared by Technical Committee ISO/TC 2, *Fasteners*.

iTeh STANDARD PREVIEW
(standards.iteh.ai)

SIST ISO 7416:1996

<https://standards.iteh.ai/catalog/standards/sist/e710bed2-412d-4140-81a0-9a01a429b451/sist-iso-7416-1996>

Plain washers, chamfered, hardened and tempered for high-strength structural bolting

iTeh STANDARD PREVIEW (standards.iteh.ai)

0 Introduction

This International Standard is part of the complete ISO product standard series on hexagon drive fasteners. The series comprises:

- a) hexagon head bolts (ISO 4014, ISO 4015 and ISO 4016);
- b) hexagon head screws (ISO 4017 and ISO 4018);
- c) hexagon nuts (ISO 4032, ISO 4033, ISO 4034, ISO 4035 and ISO 4036);
- d) hexagon flanged bolts;¹⁾
- e) hexagon flanged screws;¹⁾
- f) hexagon flanged nuts (ISO 4161);

g) structural bolting (ISO 4775 and ISO 7411 to ISO 7417).

1 Scope and field of application

This International Standard specifies those hardened and tempered circular washers intended for assembly with large series hexagon high-strength structural bolts and nuts of diameters from M12 to M36 inclusive.

2 Reference

ISO 4759/3, *Tolerances for fasteners — Part 3: Washers for bolts, screws and nuts with thread diameters > 1 and < 150 mm — Product grades A and C.*

1) These will be the subject of a future International Standard.

ISO 7416-1984 (E)

3 Dimensions

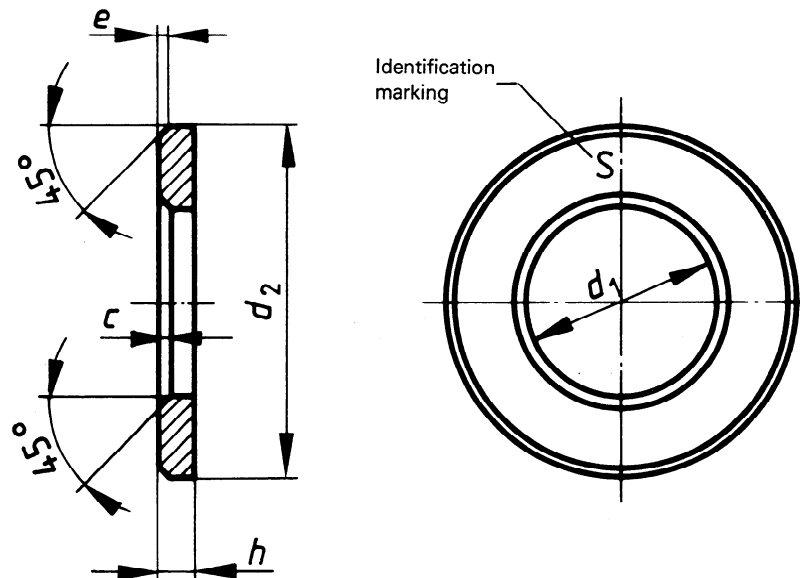

iTeh STANDARD PREVIEW
(standards.iteh.ai)

Dimensions in millimetres

Thread size, d , of associated bolt		M12	M16	M20	(M22)*	M24	(M27)*	M30	M36
d_1	min.	13	17	21	23	25	28	31	37
	max.	13,27	17,27	21,33	23,33	25,33	28,52	31,62	37,62
d_2	min.	23,7	31,4	38,4	40,4	45,4	50,4	54,1	64,1
	max.	25	33	40	42	47	52	56	66
h	min.	3,4	3,4	3,4	3,4	3,4	4,4	4,4	4,4
	max.	4,6	4,6	4,6	4,6	4,6	5,6	5,6	5,6
$e \approx$		0,5	1	1	1	1	1	1	1
c	min.	1,2	1,2	1,6	1,6	1,6	2,0	2,0	2,4
	max.	1,6	1,6	2,0	2,0	2,0	2,4	2,4	2,8

* Sizes in brackets should be avoided if possible.

4 Specifications and reference standards

Material		Steel		
Mechanical properties	Hardness range (HRC) ¹⁾	35-45		
Tolerances	Product grade	d_1 : A	d_2 : C	h : IT 17
	International Standard	ISO 4759/3		
Surface finish	normal	Black oxide ²⁾		
	optional	Zinc electroplated ³⁾ Cadmium electroplated ³⁾ Hot-dip galvanized ³⁾		
Acceptability	This will form the subject of a future International Standard.			
Associated bolts	ISO 7411 and ISO 7412			
Associated nuts	ISO 4775 and ISO 7414			

1) Minimum hardness for hot-dip galvanized washers may be 26 HRC.

2) Black oxide means the normal finish resulting from heat treatment with a light coating of oil.

3) Precautions to avoid hydrogen embrittlement may be necessary and reference should be made to the future International Standard dealing with electroplating of threaded components.

5 Designation

Example for the designation of hardened and tempered chamfered washers for high-strength structural bolts with thread size $d = M16$:

Washer ISO 7416 - 16

6 Marking

Hardened and tempered chamfered washers shall be identified by the external chamfer as shown in the figure, and an indented letter S.

(standards.iteh.ai)

SIST ISO 7416:1996

<https://standards.iteh.ai/catalog/standards/sist/e710bed2-412d-4140-81a0-9a01a429b451/sist-iso-7416-1996>