



Designation: B 804 – 96

Standard Specification for UNS N08367 and UNS N08926 Welded Pipe¹

This standard is issued under the fixed designation B 804; the number immediately following the designation indicates the year of original adoption or, in the case of revision, the year of last revision. A number in parentheses indicates the year of last reapproval. A superscript epsilon (ϵ) indicates an editorial change since the last revision or reapproval.

1. Scope

1.1 This specification covers UNS N08367 and UNS N08926 welded pipe for general corrosion applications. (Although no restrictions are placed on the sizes of pipe that may be furnished under this specification, commercial practice is commonly limited to sizes not less than 8 in. nominal diameter.)

1.2 Six classes of pipe are covered as follows:

1.2.1 Class 1 pipe shall be double welded by processes employing filler metal in all passes and shall be completely radiographed.

1.2.2 Class 2 pipe shall be double welded by processes employing filler metal in all passes. No radiography is required.

1.2.3 Class 3 pipe shall be double welded by processes employing filler metal in all passes except the inside root weld may be made without the addition of filler metal. Welds are to be completely radiographed.

1.2.4 Class 4 pipe shall be double welded by processes employing filler metal in all passes except the inside root weld may be made without the addition of filler metal. No radiography is required.

1.2.5 Class 5 pipe shall be single welded by processes employing filler metal in all passes except that the pass exposed to the inside pipe surface may be made without the addition of filler metal. Welds are to be completely radiographed.

1.2.6 Class 6 pipe shall be single welded by processes employing filler metal in all passes except that the pass exposed to the inside pipe surface may be made without the addition of filler metal. No radiography is required.

1.3 The values stated in inch-pound units are to be regarded as the standard. The values given in parentheses are for information only.

1.4 The following safety hazards caveat pertains only to the test methods portion, Section 12, of this standard: *This standard does not purport to address all of the safety concerns, if any, associated with its use. It is the responsibility of the user*

of this standard to establish appropriate safety and health practices and determine the applicability of regulatory limitations prior to use.

2. Referenced Documents

2.1 ASTM Standards:

A 262 Practices for Detecting Susceptibility to Intergranular Attack in Austenitic Stainless Steels²

A 370 Test Methods and Definitions for Mechanical Testing of Steel Products²

B 625 Specification for UNS N08904, UNS N08925, UNS N08031, UNS N08932, UNS N08926, and UNS R20033 Plate, Sheet, and Strip³

B 688 Specification for Chromium-Nickel-Molybdenum-Iron (UNS N08366 and UNS N08367) Plate, Sheet, and Strip³

E 8 Test Methods for Tension Testing of Metallic Materials⁴

E 29 Practice for Using Significant Digits in Test Data to Determine Conformance with Specifications⁵

E 38 Methods for Chemical Analysis of Nickel-Chromium and Nickel-Chromium-Iron Alloys⁶

E 354 Test Methods for Chemical Analysis of High-Temperature, Electrical, Magnetic, and Other Similar Iron, Nickel, and Cobalt Alloys⁷

E 1019 Test Methods for Determination of Carbon, Sulfur, Nitrogen, and Oxygen in Steel and in Iron, Nickel, and Cobalt Alloys⁸

2.2 ASME Boiler and Pressure Vessel Code:⁹

Section VIII, Division 1 Rules for Construction of Pressure Vessels

Section IX Qualification Standard for Welding and Brazing Procedures, Welders, Brazers, and Welding and Brazing Operators

2.3 American Welding Society Standards:¹⁰

² Annual Book of ASTM Standards, Vol 01.03.

³ Annual Book of ASTM Standards, Vol 02.04.

⁴ Annual Book of ASTM Standards, Vol 03.01.

⁵ Annual Book of ASTM Standards, Vol 14.02.

⁶ Discontinued—see 1989 Annual Book of ASTM Standards, Vol 03.05.

⁷ Annual Book of ASTM Standards, Vol 03.05.

⁸ Annual Book of ASTM Standards, Vol 03.06.

⁹ Available from American Society of Mechanical Engineers, 345 E. 47th St., New York, NY 10017.

¹⁰ Available from American Welding Society, 550 N.W. Le Jeune Rd., Miami, FL 33126.

¹ This specification is under the jurisdiction of ASTM Committee B-2 on Nonferrous Metals and Alloys and is the direct responsibility of Subcommittee B02.07 on Refined Nickel and Cobalt, and Alloys Containing Nickel or Cobalt or Both as Principal Constituents.

Current edition approved May 10, 1996. Published June 1996. Originally published as B 804 – 89. Last previous edition B 804 – 93.



AWS A5.11 Nickel and Nickel Alloy Covered Welded Electrodes

AWS A5.14 Nickel and Nickel Alloy Bare Welding Rods and Electrodes

3. Ordering Information

3.1 Orders for material under this specification shall include the following information:

- 3.1.1 Quantity (feet or number of lengths),
- 3.1.2 Class (see 1.2),
- 3.1.3 Size (outside diameter and minimum wall thickness),
- 3.1.4 Length (specific or random),
- 3.1.5 ASTM specification number,
- 3.1.6 Authorization for repair of plate defects by welding without prior approval if such is intended (see 8.4),
- 3.1.7 Circumferential weld permissibility (see 7.3.2), and
- 3.1.8 Supplementary requirements.

4. Materials and Manufacture

4.1 *Materials*—The starting material shall conform to the requirements of Specification B 688 for UNS N08367 and Specification B 625 for UNS N08926.

4.2 *Manufacture*:

4.2.1 The joints shall be double or single welded, full penetration welds made in accordance with ASME Boiler and Pressure Vessel Code, Section IX.

4.2.2 The welds shall be made either manually or automatically by an electric process involving the deposition of filler metal according to the class specified.

4.2.3 The weld surface on either side of the weld shall be flush with the base plate or shall have a reasonably uniform crown, not to exceed 1/8 in. (3.2 mm). Any weld reinforcement may be removed at the manufacturer's option or by agreement between the manufacturer and purchaser. The contour of the reinforcement shall be reasonably smooth and free of irregularities. The deposited metal shall be fused uniformly into the plate surface. No concavity of contour is permitted unless the resulting thickness of weld metal is equal to or greater than the minimum thickness of the adjacent base metal.

4.2.4 Weld defects shall be repaired by removal to sound metal and rewelding. Subsequent heat treatment and inspection shall be as required on the original welds.

4.3 *Heat Treatment*—The recommended heat treatment shall consist of heating to a minimum temperature of 2025°F for UNS N08367 and 2012°F for UNS N08926 followed by quenching in water or rapidly cooling by other means.

5. Chemical Composition

5.1 The chemical composition of the pipe shall conform to the requirements in Table 1 of Specification B 688 for UNS N08367 and Table 1 of Specification B 625 for UNS N08926.

5.2 The alloy content of the deposited weld metal shall conform to that required for the plate or the welding electrodes as shown in Specification AWS 5.11 for ENiCrMo-3, ENiCrMo-4, and ENiCrMo-10 or AWS 5.14 for ERNiCrMo-10, ERNiCrMo-3, and ERNiCrMo-4.

5.3 If product analysis is made of the plate or weld metal by the purchaser, the chemical composition thus determined shall conform to the requirements specified in 5.1 and 5.2 subject to

the permissible tolerances in Table 1 of Specification B 688 for UNS N08367 and specified in 5.1 and 5.2 subject to the permissible tolerances in Table 2 of Specification B 625 for UNS N08926.

6. Mechanical Properties and Other Requirements

6.1 *Mechanical Properties*:

6.1.1 The mechanical properties of the plate shall be in accordance with Table 1. Tension tests made by the plate manufacturer shall qualify the plate material.

6.1.2 Transverse tension tests taken across the welded joint shall have the same minimum ultimate tensile strength as the specified minimum ultimate tensile strength of the plate.

6.2 *Transverse Guided Weld Bend Test Requirements*—Bends made in accordance with Fig. 1 shall be acceptable if no cracks or other imperfections exceeding 1/8 in. (3.2 mm) in any direction are present in the weld metal or between the weld and the pipe metal after bending. Cracks that originate along the edges of the specimen during testing, and that are less than 1/4 in. (6.3 mm) measured in any direction, shall not be considered.

6.3 *Pressure Test*—Any pipe that shows leaks during the pressure test conducted in accordance with 12.4 shall be rejected, but any leaking areas may be cut out and the pipe retested as above.

6.4 *Radiographic Examination*—For Classes 1, 3, and 5 pipe, radiographic examination shall be in accordance with the requirements of the *ASME Boiler and Pressure Vessel Code*, Section VIII, latest edition, Paragraph UW-51.

7. Dimensions, Mass, and Permissible Variations

7.1 Permissible variations in dimensions at any point in a length of pipe shall not exceed the following:

7.1.1 *Outside Diameter*—Based on circumferential measurement, ±0.5 % of the nominal outside diameter.

7.1.2 *Out-of-Roundness*—Differences between major and minor outside diameters, 1.0 % of the specified outside diameter.

7.1.3 *Alignment (Camber)*—Using a 10-ft (3-m) straight-edge placed so that both ends are in contact with the pipe, the camber shall not be more than 1/8 in. (3.17 mm).

7.2 *Thickness*—The minimum wall thickness at any point in the pipe shall not be more than 0.01 in. (0.25 mm) under the nominal thickness.

7.3 *Lengths*:

7.3.1 The lengths required shall be specified in the orders.

7.3.2 Circumferentially welded joints of the same quality as the longitudinal joints shall be permitted by agreement between the manufacturer and the purchaser.

TABLE 1 Mechanical Property Requirements

Gage	Tensile Strength, min		Yield Strength, min		Elongation in 2 in. or 50.8 mm, min, %	
	ksi	MPa	ksi	MPa		
UNS N08367	≤3/16	100	690	45	310	30
	>3/16	95	655	45	310	30
UNS N08926		94	650	43	295	35

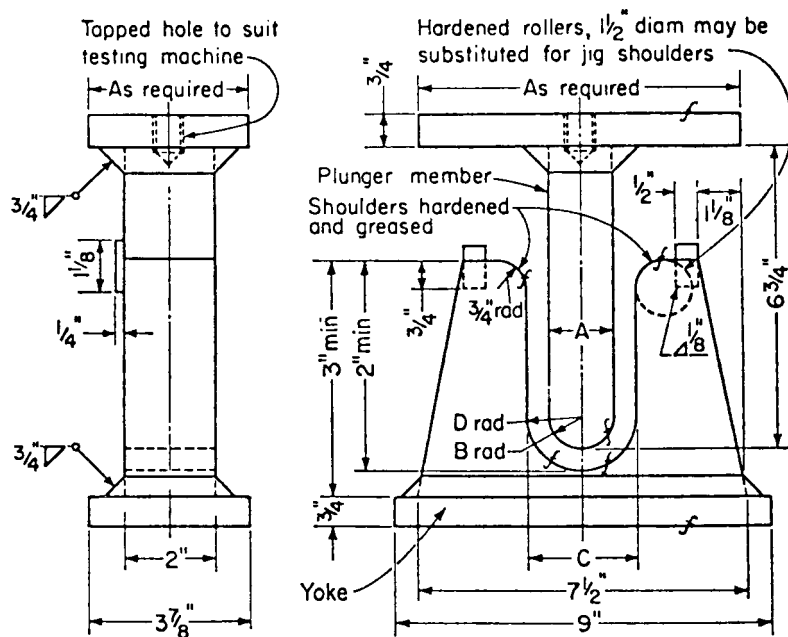

NOTE 1—1 in. = 25.4 mm.

Test Specimen Thickness, in.	A	B	C	D
$\frac{3}{8}$	$1\frac{1}{2}$	$\frac{3}{4}$	$2\frac{3}{8}$	$1\frac{3}{16}$
t	$4t$	$2t$	$6t + \frac{1}{8}$	$3t + \frac{1}{16}$

FIG. 1 Guided-Bend Test Jig

8. Workmanship, Finish, and Appearance

8.1 Pipe shall be furnished with smooth ends, free of burrs.

8.2 The finished pipe shall be free of injurious defects and shall have a workmanlike finish.

8.3 *Repair of Plate Defects by Machining or Grinding*—Pipe showing moderate slivers may be machined or ground inside or outside to a depth that shall ensure the removal of all included scale and slivers, provided the wall thickness is not reduced below the specified minimum wall thickness. Machining or grinding shall follow inspection of the pipe as rolled and shall be followed by supplementary visual inspection.

8.4 *Repair of Plate Defects by Welding*—Repair of injurious defects shall be permitted only with the approval of the purchaser. Defects shall be thoroughly chipped out before welding. The repairs shall be radiographed and if the pipe itself has already been heat treated, it shall then be heat treated again except in the case of small welds that, in the estimation of the purchaser's inspector, do not require heat treatment. Each length of pipe repaired in this manner shall be hydrostatically tested after being repaired.

8.5 The pipe shall be sandblasted or pickled to remove all scale and then passivated.

9. Sampling

9.1 *Lots for Chemical Analysis and Mechanical Testing:*

9.1.1 *Heat Analysis*—A lot shall consist of one heat.

9.1.2 *Mechanical Testing*—A lot shall consist of the material of the same nominal size from one heat and condition.

9.2 *Sampling for Chemical Analysis:*

9.2.1 A representative sample shall be taken by the plate manufacturer during pouring or subsequent processing.

9.2.2 Product analysis, if performed, shall be wholly the responsibility of the purchaser.

9.3 *Sampling for Mechanical Properties*—Transverse tension and bend test specimens shall be cut after final heat treatment from the end of the finished pipe or from a test plate of the same material as the pipe that is attached to the end of the cylinder and welded as a prolongation of the longitudinal pipe seam.

10. Number of Tests and Retests

10.1 *Chemical Analysis*—One test per lot.

10.2 *Transverse Tension Test*—One per lot.

10.3 *Transverse Guided Weld Bend Test*—One face bend and one root bend per lot (Fig. 2).

10.4 *Pressure Test*—Each pipe shall be subjected to the pressure test.

10.5 *Retests:*

10.5.1 If the results of any mechanical tests of pipe material of any lot do not conform to the requirements specified in Section 6, retests shall be made on double the original number from the same lot, each of which shall conform to the requirements specified.

10.5.2 If the results of the mechanical tests of any lot do not conform to the requirements specified, such lot may be reworked and resubmitted. The same number of tests as originally specified shall be required on reworked and resubmitted pipe.

11. Specimen Preparation

11.1 The test specimens required by this specification shall conform to those described in Test Methods and Definitions A 370.