International Standard



7480

INTERNATIONAL ORGANIZATION FOR STANDARDIZATION • МЕЖДУНАРОДНАЯ ОРГАНИЗАЦИЯ ПО СТАНДАРТИЗАЦИИ • ORGANISATION INTERNATIONALE DE NORMALISATION

Information processing — Start-stop transmission signal quality at DTE/DCE interfaces

Traitement de l'information — Qualité des signaux de transmission arythmique aux interfaces ETTD/ETCD

First edition — 1984-10-01

ITeH STANDARD PREVIEW
(standards.iteh.ai)

[ISO 7480:1984](#)

<https://standards.iteh.ai/catalog/standards/sist/5fc4670a-e8b9-4ab9-9c3c-1288a9befe81/iso-7480-1984>

UDC 621.327.8 : 621.391.8

Ref. No. ISO 7480-1984 (E)

Descriptors : data processing, data transmission, start-stop transmission, signals, quality, data terminal equipment, data circuit-terminations, definitions, signal generators, tests, electrical tests, specifications.

Price based on 10 pages

Foreword

ISO (the International Organization for Standardization) is a worldwide federation of national standards bodies (ISO member bodies). The work of preparing International Standards is normally carried out through ISO technical committees. Every member body interested in a subject for which a technical committee has been established has the right to be represented on that committee. International organizations, governmental and non-governmental, in liaison with ISO, also take part in the work.

Draft International Standards adopted by the technical committees are circulated to the member bodies for approval before their acceptance as International Standards by the ISO Council. They are approved in accordance with ISO procedures requiring at least 75 % approval by the member bodies voting.

International Standard ISO 7480 was prepared by Technical Committee ISO/TC 97, *Information processing systems*.

iteh STANDARD PREVIEW
(standards.iteh.ai)

ISO 7480:1984

<https://standards.iteh.ai/catalog/standards/sist/5fc4670a-e8b9-4ab9-9c3c-1288a9befe81/iso-7480-1984>

Information processing — Start-stop transmission signal quality at DTE/DCE interfaces

1 Scope and field of application

1.1 This International Standard provides a guide for signal quality requirements for serial data transmission at the interface between start-stop transmission Data Terminal Equipment (DTE) and Data Circuit-terminating Equipment (DCE). The interface referred to in this International Standard conforms to CCITT Recommendations V.24 (telephone networks), X.24 (data networks) and the transmitting/receiving equipment to CCITT Recommendations V.21, V.22, V.22 bis, V.23, V.26 ter, X.20, X.20 bis together with V.28, or X.20 together with X.26 (= V.10) and/or X.27 (= V.11).

The signal quality requirement is limited to start-stop transmission at the interface with asynchronous DCEs or synchronous DCEs such as CCITT type V.22. Signal quality pertaining to synchronous DTEs is not part of this International Standard.

1.2 This International Standard recognizes the need to have a number of different performance categories of signal quality depending on the type of timing used. Two types of timing are distinguished, electronic timing and mechanical timing, and the appropriate characteristics are indicated in the table.

Four signal quality categories are defined for transmitting DTEs. The categories I and II have been chosen to cover equipment using all electronic signal generation. Category II is for the attachment of start-stop transmitting DTEs to synchronous DCEs. Categories P1 and P2 are provided for DTEs using mechanical timing. Complementary categories for receiving DTEs are shown under the headings A, B, PA and PB.

The signal quality characteristics apply to data circuits regardless of whether or not multiplexing equipment is included. They do not apply to tandem data circuits where no signal regeneration is provided between interconnected sections.

A number of signal quality categories, therefore, are defined for transmitting equipment and for receiving equipment, the intention being that any receiving equipment may operate with any transmitting equipment, the actual selection being dependent

upon such factors as channel characteristics, and economic considerations of the data communication system.

1.3 This International Standard is of particular importance when the transmitting or receiving equipment are furnished by different organizations. It does not attempt to indicate what action, if any, is to be taken if the limits are not met, but it is intended to provide a basis for agreement between parties involved.

1.4 This International Standard does not describe the signal quality of the DCE or the line associated with it. Neither does it describe any requirement for an acceptable bit error rate.

2 References

ISO 2382/9, *Data processing — Vocabulary — Part 09 — Data communication*.

CCITT Definitions, *Green Book*, Vol. VIII, 1972.

CCITT V and X-series recommendations, *Yellow Book*, Vol. VIII, 1981.

CCITT Recommendation V.10, *Electrical characteristics for unbalanced double-current interchange circuits for general use with integrated circuit equipment in the field of data communications*.

CCITT Recommendation V.11, *Electrical characteristics for balanced double-current interchange circuits for general use with integrated circuit equipment in the field of data communications*.

CCITT Recommendation V.21, *300 bits per second duplex modem standardized for use in the general switched telephone network*.

CCITT Recommendation V.22, *1 200 bits per second duplex modem standardized for use on the general switched telephone network and on leased circuits*.

CCITT Recommendation V.22 bis, 2 400 bits per second duplex modem using the frequency division technique standardized for use on the general switched telephone network and on point-to-point 2-wire leased telephone-type circuits.

CCITT Recommendation V.23, 600/1 200 baud modem standardized for use in the general switched telephone network.

CCITT Recommendation V.24, List of definitions for interchange circuits between data terminal equipment and data circuit-terminating equipment.

CCITT Recommendation V.26 ter, 2 400 bits per second duplex modem using the echo cancellation technique standardized for use on the general switched telephone network and on point-to-point 2-wire leased telephone-type circuits.

CCITT Recommendation V.28, Electrical characteristics for unbalanced double-current interchange circuits.

CCITT Recommendation X.20, Interface between data terminal equipment (DTE) and data circuit-terminating equipment (DCE) for start-stop transmission services on public data networks.

CCITT Recommendation X.20 bis, V.21-compatible interface between data terminal equipment (DTE) and data circuit-terminating equipment (DCE) for start-stop transmission services on public data networks.

CCITT Recommendation X.24, List of definitions for interchange circuits between data terminal equipment (DTE) and data circuit-terminating equipment (DCE) on public data networks.

3 Definitions

For the purpose of this International Standard, the following definitions apply:

3.1 electronic timing : A signal which serves to determine the duration of signal elements and to achieve synchronization within a transmission system; it is derived from a suitable electronic circuit such as an oscillator or delay line.

3.2 mechanical timing : A signal which serves to determine the duration of signal elements and to achieve synchronization within a transmission system; it is generally derived from the angular velocity of an electric motor (power line frequency used as timing source is also included in this category).

3.3 start-stop system : Data transmission system in which each signal representing a character is preceded by a start signal which serves to prepare the receiving device for the reception of a character signal and registration of a character, and is followed by a stop signal which serves to prepare the receiving device for the reception of a subsequent start signal.

3.4 start-stop transmission (see ISO 2382/9): Asynchronous transmission such that each group of signals representing a character is preceded by a start signal and is followed by a stop signal.

3.5 continuous start-stop operation : Method of operation in start-stop transmission in which the signals representing a series of characters follow one another contiguously (for example, in sending steadily from a perforated paper tape as compared to manual keyboard operation).

3.6 signal element (ITU 52.04)¹⁾ : Each of the parts constituting a telegraph or data signal and distinguished from the others by its nature, magnitude, duration and relative position (or by one or some of these features only).

3.7 unit interval (UI) (ITU 31.26) : In a system using an equal length code, or in a system using an isochronous modulation, the interval of time such that the theoretical durations of the significant intervals of a telegraph modulation (or restitution) are whole multiples of this interval.

3.8 modulation rate (ITU 31.27) : Reciprocal of the unit interval measured in seconds. This rate is expressed in baud.

3.9 baud (ITU 31.28) : The unit of modulation rate. It corresponds to a rate of one unit interval per second.

Example:

If the duration of the unit is 20 ms, the modulation rate is 50 baud.

3.10 character interval : The duration of a character expressed as the total number of unit intervals (including information and parity check) plus the start and stop signals.

3.11 start signal (see ISO 2382/9: In start-stop transmission, a signal at the beginning of a character that prepares the receiving device for the reception of the code elements.

NOTE — A start signal is limited to one signal element generally having the duration of a unit interval.

3.12 start transition : In a character transmitted in a start-stop system, the mark-to-space transition at the beginning of the start signal.

NOTE — For mark, space, see ITU 31.37.

3.13 stop signal (see ISO 2382/9): In start-stop transmission, a signal at the end of a character that prepares the receiving device for the reception of a subsequent character.

NOTE — A stop signal is usually limited to one signal element having any duration equal to or greater than a specified minimum value.

1) ITU — International Telecommunication Union.

3.14 degree of start-stop distortion (ITU 33.08) :

(1) Ratio to the unit interval of the maximum measured difference, irrespective of sign, between the actual and theoretical intervals separating any significant instant of modulation (or of restitution) from the significant instant of the start element immediately preceding it.

(2) The highest absolute value of individual distortion affecting the significant instants of a start-stop modulation.

The degree of distortion of a start-stop modulation (or restitution) is usually expressed as a percentage.

NOTES

- 1 The result of the measurement should be completed by an indication of the period, usually limited, of the observation.
- 2 Distinction can be made between the degree of late (or positive) distortion and the degree of early (or negative) distortion.
- 3 The theoretical intervals are related to the mean actual incoming modulation rate and not necessarily to the nominal modulation rate.

3.15 degree of gross start-stop distortion (ITU 33.09, 52.64) : Degree of distortion determined when the unit interval and the theoretical intervals assumed are exactly those appropriate to the nominal modulation rate.

NOTE — The result of the measurement should be completed by an indication of the period, usually limited, of the observation.

For a prolonged modulation (or restitution) it will be appropriate to consider the probability that an assigned value of the degree of distortion will be exceeded.

In accordance with definition ITU 31.23, theoretical duration of a significant interval, in practical measurements the unit interval and the theoretical significant intervals considered are those corresponding to the actual average rate of modulation.

3.16 degree of synchronous start-stop distortion (ITU 33.10, 52.65) : Degree of distortion determined when the unit interval and the theoretical intervals assumed are those appropriate to the actual mean rate of modulation (or of restitution).

NOTES

- 1 As for ITU 33.09 and 52.64.
- 2 The degree of distortion is the time displacement of the transitions between signal states from their ideal instants.

3.17 margin (ITU 34.03) : Maximum degree of distortion compatible with a correct translation when the signals are presented to a receiver under the most unfavourable conditions so far as the composition of the signals and of the distortion is concerned.

The maximum degree of distortion which results in incorrect translation applies without reference to the form of distortion affecting the signals. In other words it is the maximum value of the most unfavourable distortion causing incorrect translation which determines the value of the margin.

3.17.1 synchronous margin (ITU 34.09) : Margin represented by the degree of distortion for the margin indicated in ITU 34.03, margin, when the mean unit interval of the modulation applied to the apparatus is equal to that which would result from a transmission from the apparatus under examination, assuming it to include a transmitter as well as a receiver.

3.17.2 net margin (ITU 34.031, 52.68) : Margin represented by the degree of distortion indicated in ITU 34.03, margin, when the rate of modulation applied to the apparatus is exactly equal to the standard theoretical rate.

3.17.3 practical margin : Net margin whereby no signal element duration is less than a specified value.

3.18 asynchronous DCE : The DCE is considered to be asynchronous if signal element timing interchange circuits are not required at either the transmitting equipment or the receiving equipment.

4 Speed characteristics

The nominal value of the modulation rate and the character interval are application dependent and therefore not part of this International Standard.

5 Signal quality from the transmitting DTE

Start-stop transmitting DTEs should operate within the specified system quality category as shown in the table. The alphabetical designations in the following clauses refer to the values specified in the same table.

5.1 Distortion of the transmitting DTE

The signal provided by the transmitting DTE on CCITT circuit 103 (V.24), or circuit T (X.24), should have a degree of synchronous start-stop distortion not greater than N % and a degree of gross start-stop distortion not greater than P %, provided that no signal element has a duration of less than Q % of the unit interval.

5.2 Character interval

In continuous start-stop operation the signals on CCITT circuit 103, or circuit T, may have a minimum average character interval which is shorter than the nominal character interval and an occasional character having a still shorter duration called the minimum character interval according to the following requirements.

5.2.1 Minimum average character interval

The interval between successive start transitions on CCITT circuit 103, or circuit T, averaged over S consecutive characters should be not less than the nominal character interval reduced by R % of the unit interval.

5.2.2 Minimum character interval

The interval between successive start transitions on CCITT circuit 103, or circuit T, should not be less than the nominal character interval reduced by T % of the unit interval.

5.3 Modulation rate accuracy

The difference between the actual average rate of modulation of the signal and the nominal modulation rate should not exceed M %.

6 Margin of receiving DTE

Receiving DTEs should operate within the specified signal quality category as shown in the table.

6.1 Margin of the receiver

In start-stop transmission, the receiving DTE is expected to have a synchronous margin of U % when specified and a practical margin of V %, and is not expected to respond to any signal element having a duration of less than W % of the unit interval.

A suitable set of characters should be taken for continuously repeated testing. Also means should be provided to determine the point when the translation of test characters becomes erroneous.

6.2 Character interval

In continuous start-stop operation the receiving DTE should respond to signals on CCITT circuit 104, or circuit R, which have a minimum average character interval which is shorter than the nominal character interval and an occasional character having a still shorter duration called the minimum character interval, according to the following requirements.

6.2.1 Minimum average character interval

The receiving DTE should be prepared to respond to successive start transitions on CCITT circuit 104, or circuit R, which follow their previous start transitions by a character interval, averaged over S consecutive characters, which is not less than the nominal character interval reduced by X % of the unit interval.

6.2.2 Minimum character interval

When the above average is met, the receiving DTE should be prepared to respond to a start transition on CCITT circuit 104, or circuit R, which follows the start transition of the preceding character by an interval which is not less than the nominal character interval reduced by Y % of the unit interval.

6.3 Minimum duration start element

In a start-stop transmission, the receiving DTE is not required to start reception of a character on a space condition on CCITT circuit 104, or circuit R, which has a duration of less than Z % of the unit interval.

7 Measurements at the interchange point

Measurements of distortion on interchange circuits should meet one out of three sets of requirements depending on whether the electrical interface characteristics comply with the CCITT recommendation V.28 or V.10 (= X.26) or V.11 (= X.27).

NOTE — The following subclauses define for the distortion measurement the necessary test loads which are not at present specified in CCITT recommendations V.10 and V.11.¹⁾

7.1 Measurement of the V.28 generator characteristics

7.1.1 Use of standard test load

Distortion measurement should be made on the particular interchange circuit of interest at the generator side while the circuit is terminated with the standard test load. This standard test load may be the input impedance of the test device or may be an external device but in all cases the total load on the interchange circuit should meet the following specification.

7.1.2 Specification of the standard test load

The standard test load should consist of 3 000 Ω resistance shunted by 2 500 pF capacitance and should be connected from the signal interchange circuit under test to CCITT circuit 102 or circuit Ga or circuit Gb as shown in the test arrangement of figure 1.

7.1.3 Distortion of the transmitting DTE

The distortion measurement should be made using a +3,0 V and a -3,0 V threshold to determine the occurrence of signal transitions.

A mark-to-space transition should be taken to occur at the instant V_{1G} crosses +3 V on a positive going transition.

A space-to-mark transition should be taken to occur at the instant V_{1G} crosses -3 V on a negative going transition.

7.2 Measurement on the V.28 load side

7.2.1 Measurements of margin on the load side of the interface should be made using the test arrangement of figure 2 and should meet the following specification.

1) These subclauses will be reviewed when test loads are specified in recommendations V.10 and V.11.

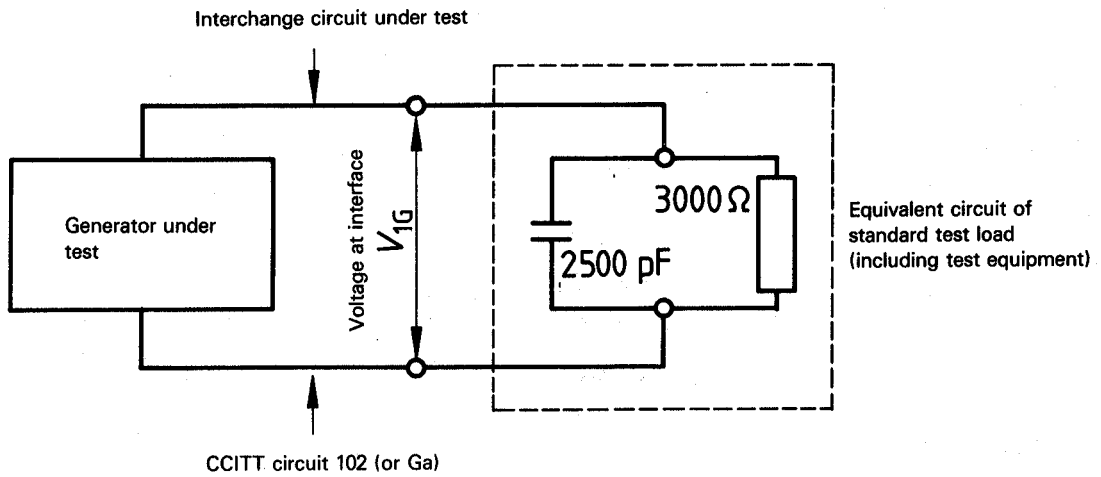

Figure 1 — Test arrangement for V.28 generators

iTeh STANDARD PREVIEW
(standards.iteh.ai)

ISO 7480:1984 Interchange circuit under test
<https://standards.iteh.ai/catalog/standards/sist/5fc4670a-e8b9-4ab9-9c3c-1288a9befe81/iso-7480-1984>

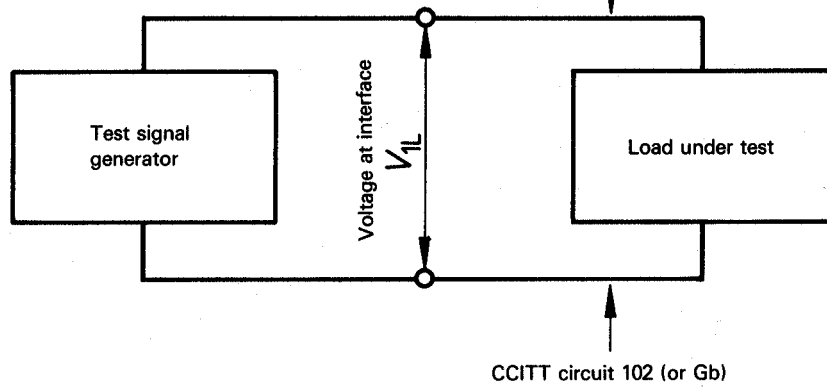

Figure 2 — Test arrangement for V.28 loads

7.2.2 Margin of receiving DTE : The measurement of the margin should be made using a signal V_{1L} of $\pm 5,0$ V when working into the load under test. The transitions of the test signal should be deviated from their ideal instants in such a way as to measure the margin (see 6.1). The deviations of the transition in time should be taken to occur when the signal crosses the $\pm 3,0$ V thresholds.

A mark-to-space transition should be taken to occur at the instant V_{1L} crosses $+3,0$ V on a positive going transition.

A space-to-mark transition should be taken to occur at the instant V_{1L} crosses $-3,0$ V on a negative going transition.

7.3 Measurement of the V.10 generator characteristics

7.3.1 Use of standard test load

Distortion measurement should be made on the particular interchange circuit of interest at the generator side while the circuit is terminated with a standard test load. This standard test load may be the input impedance of the test device or may be an external device but in all cases the total load on the interchange circuit should meet the following specification.

7.3.2 Specification of the standard test load

The standard test load should consist of 450Ω resistance shunted by a capacitance C_w and should be connected from the signal interchange circuit under test to signal common return as shown in the test arrangement of figure 3. The value of C_w depends on the data signalling rate and should be the value given in the table annexed to figure 3 but reduced by the value of any capacitance included in the generator for wave shaping.

7.3.3 Distortion of the transmitting DTE

The distortion measurement should be made using thresholds in the range $\pm 0,3$ V to determine the occurrence of signal transitions. A threshold at nominal 0 V is preferred.

7.4 Measurement on the V.10 load side

7.4.1 Measurements of margin on the load side of the interface should be made using the test arrangement of figure 4 and should meet the following specification.

7.4.2 Margin of receiving DTE: The measurement of the margin should be made using a signal V_{1L} of $\pm 4,0$ V when working into the load under test. The transitions of the test signal should be deviated from their ideal instants in such a way as to measure the margin (see 6.1). The deviations of the transitions in time should be taken to occur when the signal crosses the thresholds (see 7.3.3).

7.5 Measurement of the V.11 generator characteristics

7.5.1 Use of standard test load

Distortion measurement should be made on the particular interchange circuit of interest at the generator side while the circuit is terminated with a standard test load. This standard test load may be the input impedance of the test device or may be an external device but in all cases the total load on the interchange circuit should meet the following specification.

7.5.2 Specification of the standard test load

The standard test load should consist of 100Ω resistance and should be connected between the output points A and B of the generator under test as shown in the test arrangement of figure 5.

7.5.3 Distortion of the transmitting DTE

The distortion measurement should be made using thresholds in the range $\pm 0,3$ V to determine the occurrence of signal transitions. A threshold at nominal 0 V is preferred.

7.6 Measurement on the V.11 load side

7.6.1 Measurements of margin on the load side of the interface should be made using the test arrangement of figure 6 and should meet the following specification.

7.6.2 Margin of receiving DTE: See 7.4.2 and figure 6.

7.7 Accuracy of measuring equipment

This International Standard does not specify the tolerances of the standard test loads or the accuracy of the distortion measuring equipment or test signal generator.

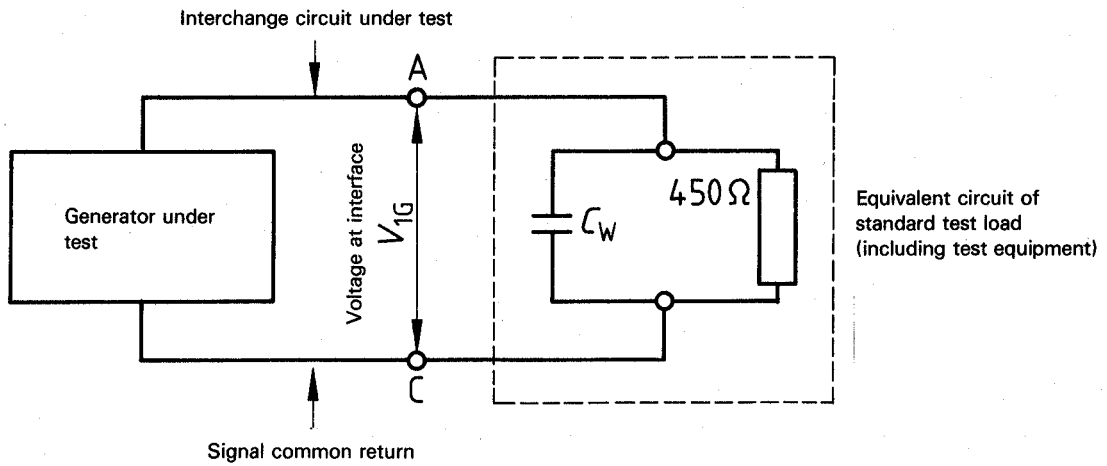

C_w (μF)	Data signalling rate (kbit/s)
1,000	0 to 2,5
0,470	2,5 to 5,0
0,220	5,0 to 10,0
0,100	10,0 to 25,0
0,047	25,0 to 50,0
0,022	50,0 to 100,0

ISO 7480:1984
<https://standards.iteh.ai/catalog/standards/sis/51e4670a-c0b9-44b9-9c3c-1288a9befe81/iso-7480-1984>

Figure 3 — Test arrangement for V.10 generators and values of C_w

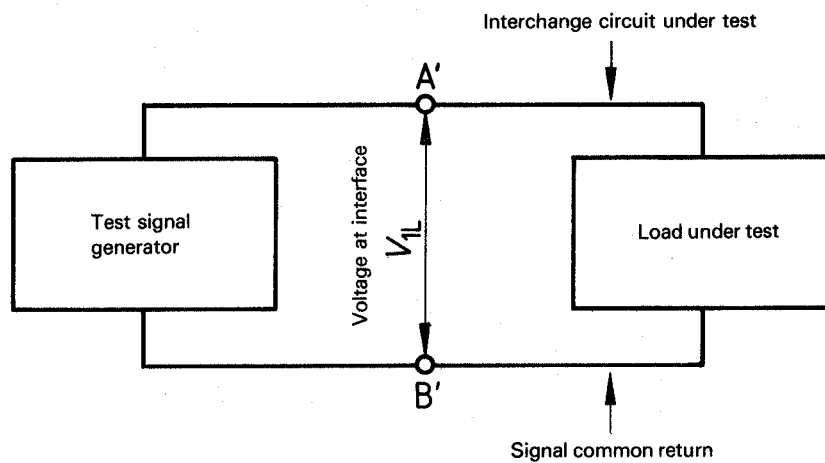

Figure 4 — Test arrangement for V.10 loads