International Standard



7493

INTERNATIONAL ORGANIZATION FOR STANDARDIZATION • МЕЖДУНАРОДНАЯ ОРГАНИЗАЦИЯ ПО СТАНДАРТИЗАЦИИ • ORGANISATION INTERNATIONALE DE NORMALISATION

Dental operator's stool

Siège d'opérateur dentaire

First edition — 1985-12-01

iTeh STANDARD PREVIEW
(standards.iteh.ai)

[ISO 7493:1985](https://standards.iteh.ai/catalog/standards/sist/357071c9-ce06-4215-9e09-bc0e3a0bc345/iso-7493-1985)

<https://standards.iteh.ai/catalog/standards/sist/357071c9-ce06-4215-9e09-bc0e3a0bc345/iso-7493-1985>

UDC 616.314-7 : 615.478.68

Ref. No. ISO 7493-1985 (E)

Descriptors : dentistry, dental equipment, dental operating chairs, seats, specifications, definitions, tests, marking.

Price based on 5 pages

Foreword

ISO (the International Organization for Standardization) is a worldwide federation of national standards bodies (ISO member bodies). The work of preparing International Standards is normally carried out through ISO technical committees. Each member body interested in a subject for which a technical committee has been established has the right to be represented on that committee. International organizations, governmental and non-governmental, in liaison with ISO, also take part in the work.

Draft International Standards adopted by the technical committees are circulated to the member bodies for approval before their acceptance as International Standards by the ISO Council. They are approved in accordance with ISO procedures requiring at least 75 % approval by the member bodies voting.

International Standard ISO 7493 was prepared by Technical Committee ISO/TC 106, *Dentistry*.

Users should note that all International Standards undergo revision from time to time and that any reference made herein to any other International Standard implies its latest edition, unless otherwise stated.

iTeh STANDARD PREVIEW
(standards.iteh.ai)

ISO 7493:1985
<https://standards.iteh.ai/catalog/standards/sist/357071e9-ce06-4215-9e09-bc0e3a0bc345/iso-7493-1985>

Dental operator's stool

0 Introduction

The objectives of this International Standard are to ensure that the design and functioning of the dental operator's stools will be such as to enable the dental operator to perform his or her work effectively and safely, to minimize the muscular and skeletal stresses, particularly in shoulders and spine, that arise during the performance of the work, and to allow freedom of movement without undue muscular activity.

1 Scope and field of application

This International Standard specifies requirements and includes methods of test to be performed on the dental operator's¹⁾ stool to cover ergonomic, hygienic and safety characteristics.

2 Definitions

For the purposes of this International Standard, the following definitions apply.

2.1 dental operator's stool: A mobile chair, adjustable in height, which satisfies the general requirements relevant to the performance of dentistry by a seated operator.

2.2 seat height (see *A* in the figure): The vertical distance between the intersection point of the swivel axis with the loaded surface of the seat and the floor.

2.3 seat width (see *B* in the figure): The horizontal distance passing through the swivel axis of the seat between the upper edges of the sides of the seat measured perpendicularly to the anteroposterior plane of the seat.

2.4 seat depth (see *C* in the figure): The horizontal distance measured through the centre of width *B* through the anteroposterior plane of the seat between the vertical projections of the front and back edges.

If the stool is provided with a backrest, this distance is measured between the foremost projection of the centreline of the backrest and the normal projection of the front edges.

2.5 reference point Z: The intersection of the swivel axis of the seat and the upper surface of the loaded seat.

2.6 backrest reference point (see *X* in the figure): The centre of the area on the backrest that provides lumbar support.

2.7 backrest height (see *W* in the figure): The vertical height from *X* to *Z*, measured with the seat loaded.

For this measurement the backrest shall be adjusted in its most forward position and, if it can be pivoted about a horizontal axis, it shall be put in the vertical position.

2.8 least favourable position: The position of the seat for which the load-bearing member of the seat and two adjacent castors, where applicable, are placed in their least favourable positions (as shown on the figure) with regard to the seat stability.

1) For the purposes of this International Standard, the dental operator does not include the dentist's assistant.

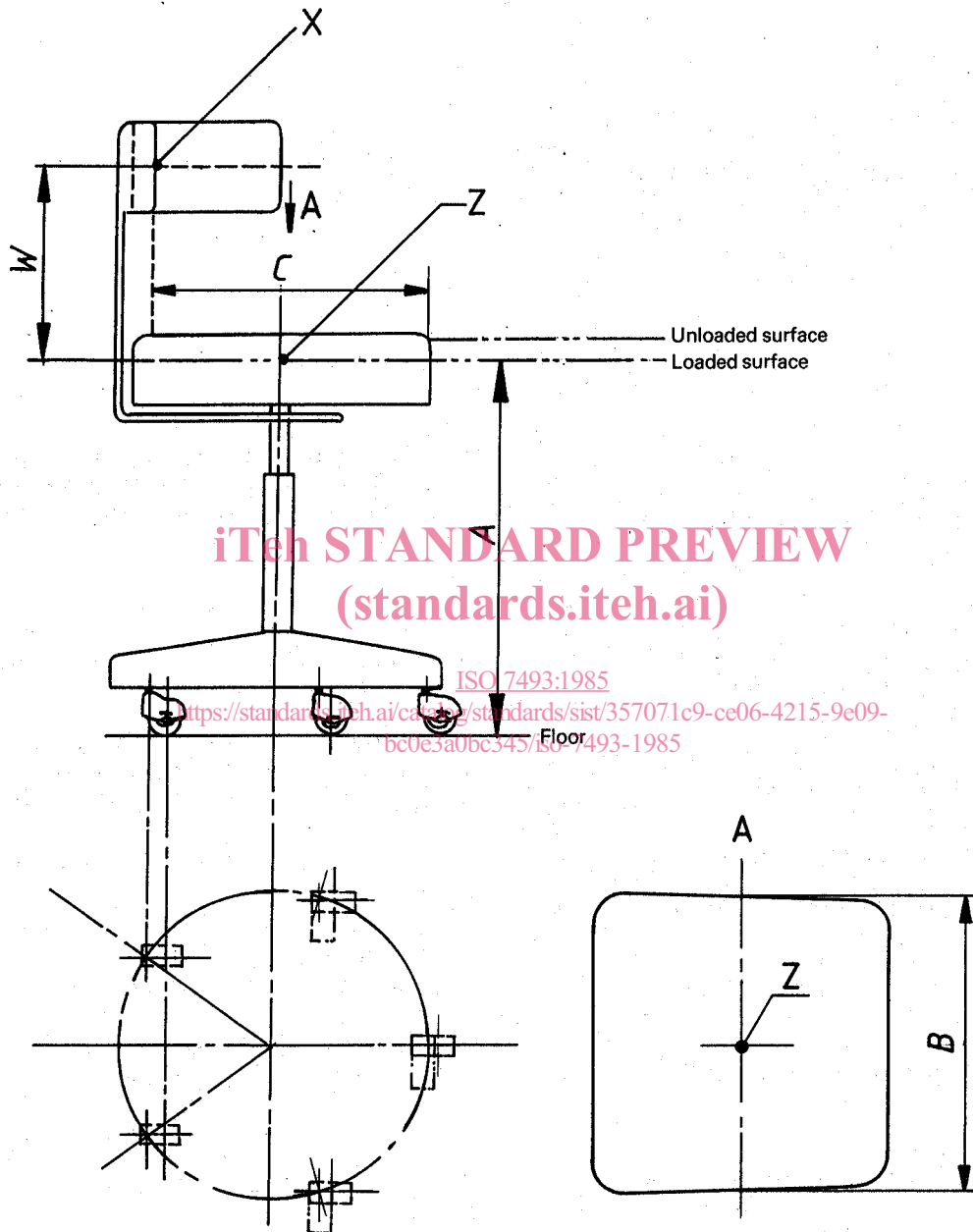

NOTE — This figure is not intended to stipulate the design of the dental operator's stool.

Figure — Illustration of dental operator's stool (see clause 2 for definitions)

3 Characteristics

3.1 General design

3.1.1 The stool should preferably be provided with a backrest, which shall be adjustable horizontally and vertically, independent of the seat adjustment.

3.1.2 In order to minimize any risk of injury or damage, projecting parts shall be avoided and the mechanical parts protected.

3.1.3 Controls for the adjustment of the seat and, where applicable, for the adjustment of the backrest shall be so disposed and located as to render their accidental actuation unlikely.

The controls shall, on the other hand, be easily reached and easily operated.

3.1.4 The stool, unless otherwise specified, shall be easily movable in the unloaded or loaded condition.

3.1.5 The upper part of the stool shall not be capable of being removed from the base without the use of a tool, and the seat shall swivel on a vertical axis.

3.1.6 If the stool is fitted with castors, the abrasion resistance of the material of construction of those surfaces intended to contact the floor shall be high enough to prevent floor coverings from being marked.

NOTE — The number, position and dimensions of the castors should be such as to minimize contact loads (and hence minimize scoring and indentation of floor coverings) and, unless otherwise specified, permit unconstrained movement the loaded or unloaded stool in any direction.

3.1.7 If a counterbalancing force is provided in the seat height adjustment mechanism, it shall ensure adequate support throughout its range of adjustment; in common practice this force is approximately 250 N.

Furthermore, when designing the stool, the manufacturer should consider the four recommendations given in the annex.

3.2 Ranges of adjustment and dimensions

3.2.1 Seat height

The minimum range of adjustment of the seat height from its highest to lowest positions shall be 140 mm.

When adjusted to its lowest position, the seat height shall, with the seat loaded, not exceed 420 mm.

3.2.2 Seat depth

The seat depth shall be at least 350 mm.

3.2.3 Seat width

The seat width shall be at least 350 mm.

3.2.4 Backrest height adjustment

If the stool is provided with a backrest, the minimum range of adjustment of the backrest height W shall, with the seat loaded, be from 170 mm to 230 mm.

NOTE — For the lateral adjustment of the backrest, see clause A.4.

3.3 Load-carrying capacity of stool

When tested in accordance with the method described in 4.1, the stool shall not collapse or yield during the application of the load (after the period of early settlement), i.e. $h_1 - h_2$, defined in 4.1, shall be equal to zero.

3.4 Stability of stool

When tested in accordance with the method described in 4.2, the stool shall not tip.

3.5 Deflection of the backrest

When tested in accordance with the method described in 4.3, the backrest shall not show an horizontal deflection at point X that exceeds 30 mm.

3.6 Cleaning and disinfection

When cleaned and disinfected according to 4.4, all exterior parts of the stool shall show no deterioration of surfaces or markings.

3.7 Flammability

When tested in accordance with the method described in 4.5, the upholstery and padding shall not inflame and there shall be no charring or scars allowed in an area greater than 30 mm around the extinguished cigarettes.

4 Methods of test

In addition to the visual inspection necessary to ensure that the characteristics described in 3.1 are fulfilled, and the verification of dimensions, the tests specified in 4.1 to 4.5 shall be performed.

4.1 Load-carrying capacity of stool

Adjust the seat height to its maximum value.

Select and mark a suitable point on the seat, and arrange means for determining its vertical distance from some other suitable point mounted on the floor.

Apply and maintain a mass of 135 kg at the centre of the seat.

After allowing a period for early settlement to occur and cease, determine the value of the vertical distance (h_1).

After 15 min, redetermine the value of the vertical distance (h_2).

Report the value of $h_1 - h_2$.

4.2 Stability verification

Adjust the stool castors and the load-bearing member in the least favourable position (as described in 2.8) and the seat at its maximum height and swivelled in its least favourable position relative to the castors.

Apply a downward vertical force of 800 N centred at a point 60 mm from the least favourable edge of the seat.

Report whether the stool tips.

4.3 Deflection of the backrest

Adjust the backrest height to its highest position.

Fix the seat rigidly with respect to the floor.

Mark the reference point X on the bracket, and determine its horizontal distance from some other suitable point clearly marked (for example on the floor). If the backrest is spring-loaded, determine this horizontal distance after full compression of the springs.

Apply a horizontal force of 250 N at the reference point X by means of a pad having a diameter of 150 mm.

Redetermine the horizontal position of the reference point X.

Calculate the deflection as the difference of the two values obtained.

4.4 Cleaning and disinfection

Clean and disinfect all exterior parts of the stool 20 times with the agents recommended by the manufacturer.

4.5 Flammability

Keep the stool to be tested 48 h in an environment having a temperature of 23 ± 2 °C and a relative humidity of (65 ± 5) %.

After conditioning in the environment described above, place three burning cigarettes on three different parts of the stool upholstery. Allow the cigarettes to burn completely.

NOTE — The test method for flammability of the upholstery is a temporary expedient, and is intended to be replaced, either by amendment or revision, by a reference to an International Standard which, at the time of publication, was in preparation.

5 Instructions for use

The manufacturer shall supply instructions for the safe operation and use of the stool. The instructions shall include step-by-step procedures for operating and maintaining the stool with illustrations showing the location of the controls, together with explanations of their use. The recommended cleaning and disinfection agents shall be given, together with instructions for their use.

6 Marking

The stool shall be marked with at least the following information:

- a) manufacturer's name or readily identifiable mark;
- b) the model and serial number.

Annex

Recommendations to manufacturers on the design of dental stools

(This annex does not form an integral part of the standard.)

- A.1** The design of the stool and backrest should facilitate a seated dental operator in adopting comfortably all the bodily positions which are usually necessary during the performance of dental operations.
- A.2** The front edge seat should be of such a shape as to minimize pressure under the thighs.
- A.3** The upholstery should be conducive to the comfort of a dental operator seated for extended periods, and over periods in which temperature and humidity may change.
- A.4** The lateral adjustment of the backrest should enable the dental operator, when in a correct working posture, to be supported by the backrest.

iTeh STANDARD PREVIEW
(standards.iteh.ai)

ISO 7493:1985

<https://standards.iteh.ai/catalog/standards/sist/357071c9-ce06-4215-9e09-bc0e3a0bc345/iso-7493-1985>

iTeh STANDARD PREVIEW
(standards.iteh.ai)

ISO 7493:1985

<https://standards.iteh.ai/catalog/standards/sist/357071c9-ce06-4215-9e09-bc0e3a0bc345/iso-7493-1985>