



Standard Test Method for Determining the Edgecomb Resistance of Woven Fabrics Used in Inflatable Restraints¹

This standard is issued under the fixed designation D 6479; the number immediately following the designation indicates the year of original adoption or, in the case of revision, the year of last revision. A number in parentheses indicates the year of last reappraisal. A superscript epsilon (ϵ) indicates an editorial change since the last revision or reappraisal.

1. Scope

1.1 This test method covers the procedures for determining the resistance to edgecombing of a woven fabric used in inflatable restraints.

1.2 Procedures and apparatus other than those stated in this standard may be used by agreement of purchaser and supplier with the specific deviations from the standard practice acknowledged in the report.

1.3 The values stated in either SI units or inch-pound units are to be regarded separately as standard. The values stated in each system are not exact equivalents; therefore, each system must be used independent of the other.

1.4 *This standard does not purport to address all of the safety concerns, if any, associated with its use. It is the responsibility of the user of this standard to establish appropriate safety and health practices and determine the applicability of regulatory limitations prior to use.*

2. Referenced Documents

2.1 ASTM Standards:

- D 76 Specification for Tensile Testing Machines for Textiles²
- D 123 Terminology Relating to Textiles²
- D 1776 Practice for Conditioning Textiles for Testing²
- D 2904 Practice for Interlaboratory Testing of a Textile Test Method that Produces Normally Distributed Data²
- D 2906 Practice for Statements on Precision and Bias for Textiles²
- D 5035 Test Method for Breaking Force and Elongation of Textile Fabrics (Raveled Strip)³
- D 5822 (Test Method for Determining Seam Strength in Inflatable Restraint Cushion)³
- E 691 Practice for Conducting an Interlaboratory Study to Determine The Precision of a Test Method²

3. Terminology

3.1 Definitions:

- 3.1.1 *edgecombing, n*—for inflatable restraints, the separation

of yarns from their normal orthogonal configuration in a woven fabric due to seam stress or similar action near the edge of a cut part

3.1.2 *inflatable restraint, n*—a vehicular safety device designed to cushion an occupant or equipment during collision; airbag.

3.1.3 *seam slippage, n*—in sewn fabrics, the displacement of the fabric yarn parallel and adjacent to the stitch line

3.1.4 *yarn slippage, n*—in sewn fabrics, the displacement of one or more yarns from the original position, causing differences in alignment, spacing, or both.

3.2 For definitions of other textile terms used in this test method, refer to Terminology D 123.

4. Summary of Test Method

4.1 One end of a test specimen is clamped within one jaw of a CRE tensile testing machine and a special fixture pierces a row of equally spaced needle holes through the opposite end of the specimen. In accordance with Test Method D 5035, a tensile force is applied to the specimen until rupture occurs. The measurement of the force required to cause rupture is the measurement of edgecomb resistance.

5. Significance and Use

5.1 A measurement of a fabric's edgecomb resistance indicates the relative tendency of a fabric to pull apart under seam stress or similar action. The related concepts of yarn slippage and seam slippage are limited to sewn seams, whereas the measurement of edgecomb resistance is made at the edge of a cut part in the absence of a sewn seam. The absence of a sewn seam in this test method eliminates the effect that a particular stitch might have on the tendency of a yarn to slip near an edge of a cut part

5.2 This test method is useful for material design evaluations in such applications as airbags in which seam stress is a major concern.

5.3 This method may be used as a complement to Test Method D 5822.

6. Apparatus

6.1 *Tensile Testing Machine*—A constant-rate-of-extension (CRE) type, that is designed for the tensile forces anticipated, that is operated at a rate of 200 ± 10 mm/min (8 ± 0.5 in./min), that has a force range selected such that the anticipated break

¹ This test method is under the jurisdiction of ASTM Committee D13 on Textiles and are the direct responsibility of Subcommittee D13.20 on Inflatable Restraints.

Current edition approved April 10, 2001. Published June 2001. Originally published as D 6479-99. Last previous edition D 6479 – 00.

² *Annual Book of ASTM Standards*, Vol 07.01.

³ *Annual Book of ASTM Standards*, Vol 07.02.

occurs between 10 and 90 % of full scale load, and that has jaws and grip faces as agreed upon by purchaser and supplier.

6.2 *Clamps*, jaws with smooth, flat, parallel faces a minimum of 60 mm wide by 25 mm tall. The jaws may be padded or coated under the jaw face area.

6.3 *Fixture*, compatible with tensile tester, equipped with twelve equally spaced 1 mm diameter pins, 8 mm in length and corresponding 1.5 mm diameter holes with a stop located 5 mm from the center of the holes (Fig. 1).

6.4 *Load Cell*, whose rated capacity is between 110 and 1000 % of expected stripping load. A 2000 N load cell is generally used for inflatable restraints.

6.5 For inflatable restraints, all test equipment used in accordance with this test method shall be certified for calibration annually by an independent agency or equipment manufacturer whose results are traceable to National Institute of Science and Technology (NIST) or other national standards laboratory. The test parameters of the equipment shall be tested within the operating ranges covered in the cushion specification or equivalent document.

7. Sampling and Specimen Preparation

7.1 Edgecomb resistance testing is a destructive test. If used in conjunction with lot testing, sampling is required.

7.2 For acceptance testing the lot size is the number of rolls of fabric produced in one production day, or as specified in the applicable material specification.

7.3 From the end of each roll of fabric taken from the lot sample, cut a 1 m long, full width sample of fabric.

7.4 From the laboratory sample, select five test specimens each from the warp and fill directions (Fig. 2).

7.5 Without sealing or unraveling the edges, cut each specimen 50 ± 1 mm wide and 300 ± 5 mm long, with the long dimension parallel to the warp yarns for a warp-oriented test, and parallel to the fill yarns for a fill-oriented test.

8. Conditioning

8.1 Specimens for edgecomb resistance testing shall be conditioned at the standard atmosphere for testing textiles for at least 4 h prior to test in accordance with Test Method D 1276.

9. Procedure

9.1 Prepare the tensile testing machine in accordance with Test Method D 5035.

9.2 Set the gage length between clamps at 200 ± 1 mm (4 ± 0.1 in).

9.3 Select the force range of the testing machine for the break to occur between 10 and 90 % of full-scale force. Calibrate or verify the testing machine for this range.

9.4 Set the testing machine for a loading rate of 200 ± 10 mm/min (8 ± 0.5 in./min).

9.5 Ensure proper clamping as directed by Test Method D 5035.

9.6 Mount one end of the specimen into the bottom clamp position of the edgecomb fixture, ensuring that the end of the specimen abuts flatly and evenly against the alignment block, parallel to and behind the pinholes.

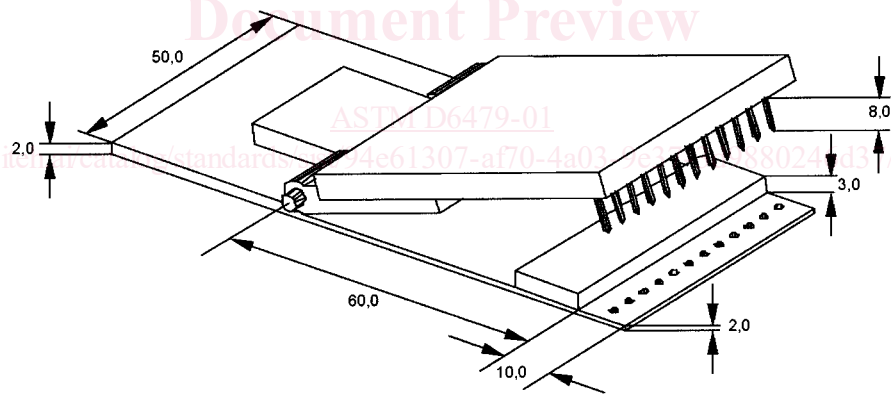

- Description: - 50,0 mm total width for baseplate of the specimens holder
- 70,0 mm total length for moveable arm of the specimens holder
- 3,0 mm distance from centre of the first needle to edge of specimens holder
- 4,0 mm distance between centres of the needles
- 1,0 mm diameter of needles
- 12 grounded needles
- 8,0 mm length of visible needles
- 10,0 mm total lock distance for specimens
- 5,0 mm distance between centre of drillings to edge of specimen holder
- 1,5 mm diameter of drillings at the base plate
- Connection between specimens holder and testing device to be fitted due to the needs of the testing device

FIG. 1 Fixture