



Standard Test Method for Fire Tests of Door Assemblies, Including Positive Pressure Testing of Side-Hinged and Pivoted Swinging Door Assemblies¹

This standard is issued under the fixed designation E 2074; the number immediately following the designation indicates the year of original adoption or, in the case of revision, the year of last revision. A number in parentheses indicates the year of last reapproval. A superscript epsilon (ϵ) indicates an editorial change since the last revision or reapproval.

INTRODUCTION

This fire-test-response standard replaces E 152, Standard Methods of Fire Tests of Door Assemblies, which was formerly under the jurisdiction of Committee E-5 on Fire Standards. The E 152 standard was withdrawn on January 1, 1995 in accordance with Section 10.5.3.1 of the *Regulations Governing ASTM Technical Committee*, which requires that standards shall be updated by the end of the eighth year since last approval date.

1. Scope

1.1 This fire-test-response standard is applicable to door assemblies for use in walls to retard the passage of fire (see X1.1-X1.3.).

1.2 This fire-test-response standard determines the ability of door assemblies to function as a fire-resistive barrier during a standard fire endurance test. Such a test method shall not be construed as determining the suitability of door assemblies for continued use after their exposure to fire.

1.3 This fire-test-response standard is intended to evaluate the ability of a door assembly to remain in an opening during a predetermined test exposure, which when required by 12.10 is then followed by the application of a hose stream (see X1.4 and X1.5).

1.4 The hose stream test used in this test method is not designed to be representative of an actual hose stream used by a fire department during fire suppression efforts.

1.5 The fire exposure is not representative of all fire conditions, which vary with changes in the amount, nature, and distribution of the fire loading, ventilation, compartment size and configuration, and heat characteristics of the compartment. It does, however, provide a relative measure of fire endurance of door assemblies under specified fire exposure conditions.

1.6 Any variation from the tested construction or test conditions will possibly change the performance characteristics of door assembly.

1.7 This fire-test-response standard *does not* provide the following:

1.7.1 The fire endurance of door assemblies constructed of materials other than those tested.

1.7.2 A temperature limit on the unexposed surface of the door assembly, although the temperatures are measured and recorded.

1.7.3 A limit on the number of openings allowed in glazed areas or of the number and size of lateral openings between the door and frame.

1.7.4 A measurement of smoke or products of combustion that pass through the door assembly.

1.7.5 A measurement of smoke, toxic gases, or other products of combustion generated by the door assembly.

NOTE 1—The information in 1.7.4 and 1.7.5 may be important in determining the fire hazard or fire risk of door assemblies under actual fire conditions. This information may be determined by other suitable fire test methods. For example, flame spread and smoke development may be determined by Test Method E 84.

1.8 *This standard does not purport to address all of the safety concerns, if any, associated with its use. It is the responsibility of the user of this standard to establish appropriate safety and health practices and determine the applicability of regulatory limitations prior to use.*

1.9 *This standard is intended to measure and describe the response of materials, products, or assemblies to heat and flame under controlled conditions and is not intended to describe or appraise the fire hazard or fire risk of materials, products, or assemblies under actual fire conditions. However, results of the test are permitted to be used as elements of a fire-hazard assessment or a fire-risk assessment which takes*

¹ This test method is under the jurisdiction of ASTM Committee E-5 on Fire Standards and is the direct responsibility of Subcommittee E05.11 on Fire Endurance.

Current edition approved March 10, 2000. Published May 2000.

into account all of the factors which are pertinent to an assessment of the fire hazard or fire risk of a particular end use.

1.10 This test method references notes and footnotes which provide explanatory material. These notes and footnotes (excluding those in tables and figures) shall not be considered as requirements of this test method.

1.11 The values stated in either inch-pound units or SI units are to be regarded separately as standard. The values stated in each system may not be exact equivalents; therefore, each system shall be used independently of the other. Combining values from the two systems may result in nonconformance with the standard.

2. Referenced Documents

2.1 ASTM Standards:

E 84 Test Method for Surface Burning Characteristics of Building Materials²

E 119 Tests Methods for Fire Tests of Building Construction and Materials²

E 152 Methods of Fire Tests of Door Assemblies³

E 176 Terminology of Fire Standards²

E 631 Terminology of Building Constructions⁴

2.2 Other Documents:

UL 385 Standard for Play Pipes for Water Supply Testing in Fire-Protection Service, 1993⁵

3. Terminology

3.1 For the purpose of this test method, the definitions given in Terminologies E 176 and E 631, together with the following, shall apply:

3.1.1 *integrity, n*—the ability of a test assembly, when exposed to fire from one side, to prevent the passage of flame and hot gases through it or the occurrence of flames on its unexposed side.

3.1.2 *through-opening, n*—an uninterrupted hole in the test assembly that is seen from the unexposed side when viewing the suspected hole from a position perpendicular to the plane of the test assembly.

4. Summary of Test Method

4.1 This fire-test-response standard describes the following test sequence and procedure.

4.1.1 A door assembly is exposed to a standard fire exposure, controlled to achieve specified temperatures and pressures throughout a specified time period.

4.1.2 The integrity of the door assembly is evaluated using a cotton wool pad test when the average unexposed surface temperature of a door assembly is less than 650°F (361°C) above ambient and openings are created by the fire exposure.

4.1.3 After the fire endurance test the door assembly is subjected to a hose stream test when required by 12.10.

5. Significance and Use

5.1 In this fire-test-response standard, the test specimens are subjected to one or more specific sets of laboratory test conditions. When different test conditions are substituted or the end-use conditions are changed, it is not always possible by, or from, this test method to predict changes to the characteristics measured. Therefore, the results are valid only for the exposure conditions described in this test method.

5.2 This fire-test-response standard measures and records the temperatures on the unexposed side of a door assembly. This data is intended to assist and enable regulatory bodies to determine the suitability of door assemblies for use in locations where fire resistance of a specified duration is required.

5.3 The data is not intended to be used to describe or appraise the fire hazard or fire risk of materials, products, or assemblies under actual fire conditions.

5.4 This fire-test-response standard requires that observations be made and recorded relevant to the passage of flame.

5.5 This fire-test-response standard uses a cotton wool pad test to assess the integrity of the door assembly relevant to the passage of hot gases.

5.6 This fire-test-response standard uses a hose stream test to assess the durability of the door assembly relevant to the passage of a stream of water.

6. Apparatus

6.1 Furnace and Test Frame:

6.1.1 The furnace construction shall be suitable to meet the requirements of the fire test protocol. An example of the furnace and test frame is illustrated in Fig. 1 (see X1.6).

6.1.2 The height and width of the furnace opening shall be greater than the test assembly's corresponding dimension.

6.1.3 The furnace shall be heated with burners that are fired using either natural gas or liquefied petroleum gases. The burners shall have a controllable heat output (see X1.8) and be able to expose the test assembly to the uniform heating of the standard time-temperature curve.

6.2 Copper Disk Thermocouples:

6.2.1 The copper disk thermocouples shall be covered by pads as specified in 6.2.4, reference Fig. 2, and shall have a

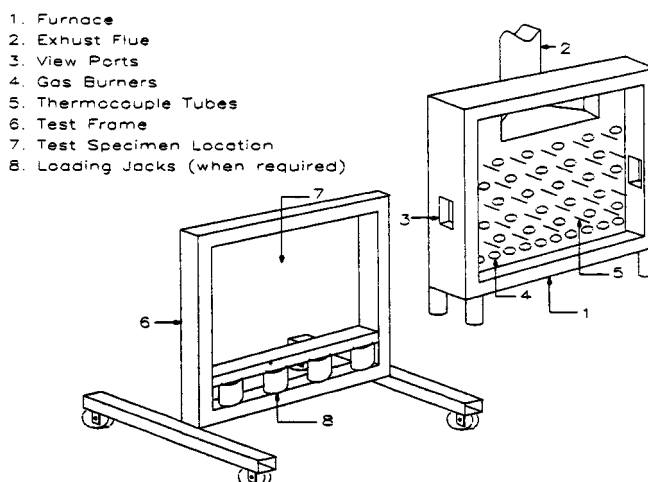

FIG. 1 Furnace and Test Frame

² Annual Book of ASTM Standards, Vol 04.07.

³ This standard was withdrawn on Jan. 1, 1995, in accordance with Section 10.5.3.1 of the Regulations Governing ASTM Technical Committees which requires that standards be updated at least every eight years.

⁴ Annual Book of ASTM Standards, Vol 04.11.

⁵ Available from Underwriters Laboratories, 333 Pfingsten Road, Northbrook, IL 60062.

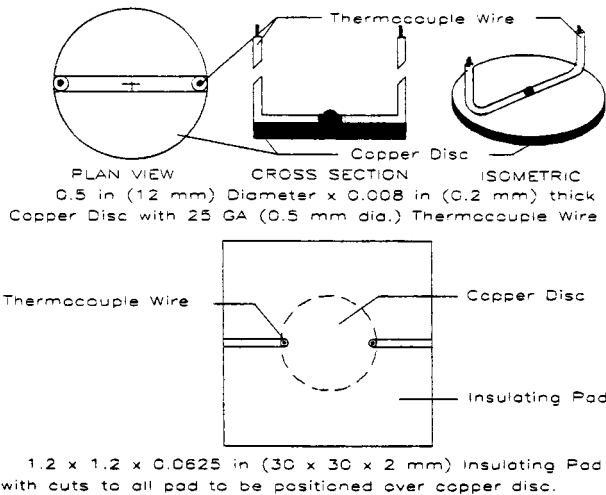

FIG. 2 Example of a Typical Thermocouple Disk and Insulating Pad

wire diameter of not more than 0.03 in. (0.7 mm), and be brazed to the center of the face of a copper disk having the following nominal measurements: ½ in. (12 mm) in diameter and 0.01 in. (0.2 mm) thick.

6.2.2 Thermocouple Insulating Pads:

6.2.2.1 Refractory fiber pads shall have the following properties:

6.2.2.1.1 *Length and Width*, 1.20 ± 0.02 in. (30 ± 0.5 mm),

6.2.2.1.2 *Thickness*, 0.08 ± 0.02 in. (2 ± 0.5 mm), and

6.2.2.1.3 *Density*, 56.2 ± 6.2 lb/ft³ (900 ± 100 kg/m³).

6.2.2.2 If necessary, it is permitted to shape the pads by wetting, forming, and then drying them to provide complete contact on sharply contoured surfaces.

6.3 *Pressure-Sensing Probes*—Except for the diameters of the steel tubes, tolerances are ±5 % of the dimensions shown in Fig. 3 or Fig. 4.

6.3.1 The pressure-sensing probes shall be either: a T-shaped sensor as shown in Fig. 3, or a tube sensor as shown in Fig. 4.

6.4 Differential Pressure Measurement Instruments:

6.4.1 The differential pressure measurement instrument shall be: a manometer or transducer, and capable of reading in graduated increments of no greater than 0.01 in. H₂O (2.5 Pa) with a precision of not less than ±0.005 in. H₂O (±1.25 Pa).

6.5 Hose Stream Delivery System:

6.5.1 The hose stream delivery system shall consist of the following:

6.5.1.1 A standard 2½-in. (64-mm) diameter hose attached to a national standard play pipe as described in UL 385.

6.5.1.2 The play pipe shall have an overall length of 30 ± 0.25 in. (762 ± 6 mm) and shall be equipped with a standard 1⅛-in. (28.5-mm) discharge tip of the standard-taper-smooth-bore pattern without shoulder at the orifice.

6.5.1.3 The play pipe shall be fitted with a standard 2½-in. (64-mm) inside dimension by 6-in. (153-mm) long nipple mounted between the hose and the base of the play pipe.

6.5.1.4 A pressure tap for measuring the water pressure at the base of the nozzle shall be normal to the surface of the nipple, shall be centered in its length, and shall not protrude into the water stream.

6.5.1.5 A suitable pressure gage capable of reading a minimum of 0 to 50 psi (0 to 344.8 kPa) and graduated into no greater than 2-psi (13.8-kPa) increments shall be used to measure the water pressure.

6.6 Furnace Thermocouples:

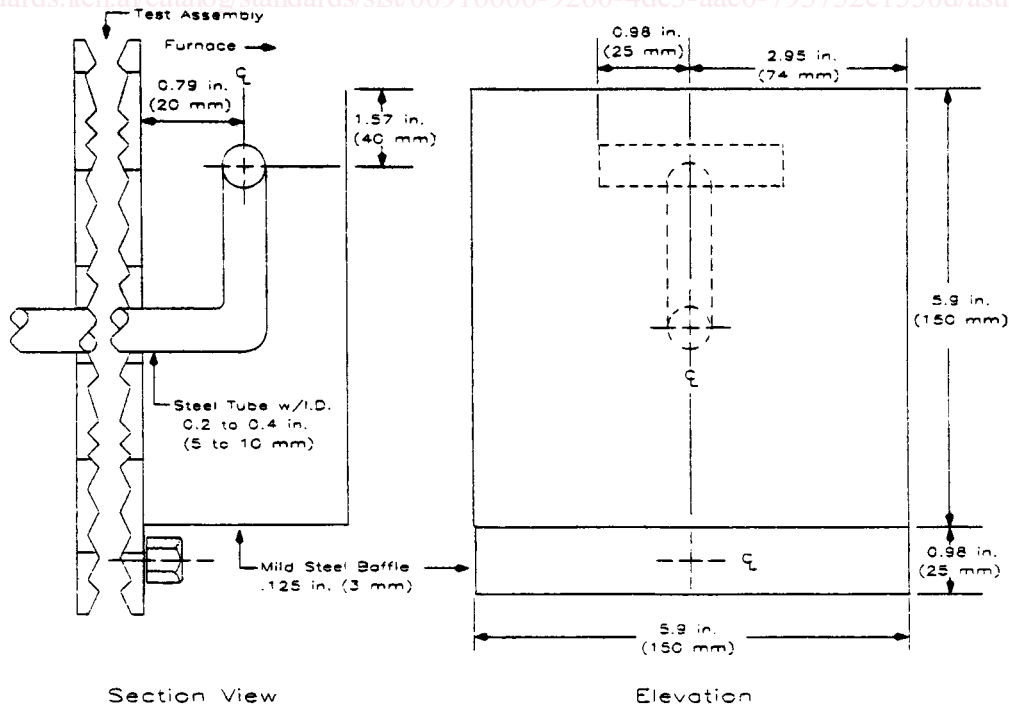
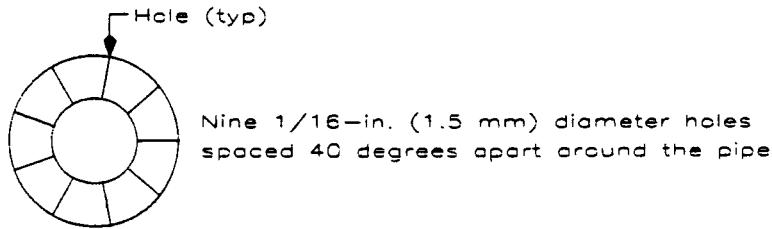
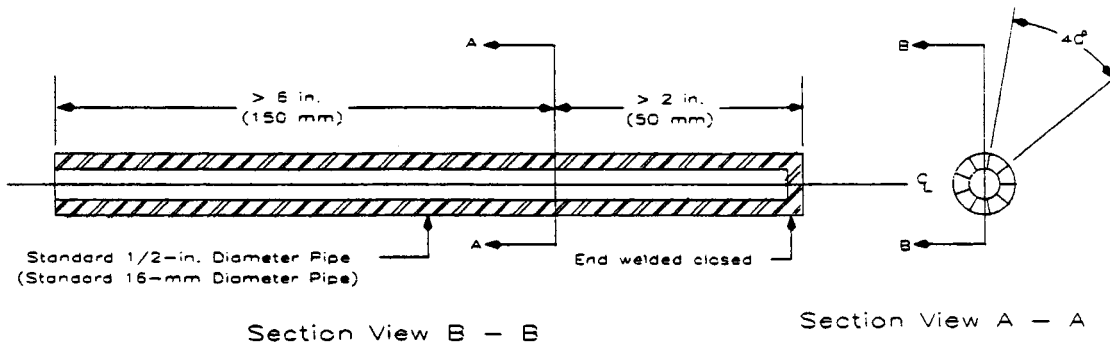

FIG. 3 T-Shaped Sensor



Enlarged Section View A - A

FIG. 4 Tube Sensor

6.6.1 The furnace thermocouples shall:

6.6.1.1 Be protected by sealed porcelain tubes having a nominal 3/4-in. (19-mm) outside diameter and 1/8-in. (3-mm) wall thickness, or, as an alternative, in the case of base metal thermocouples, protected by a standard 1/2-in. (13-mm) diameter wrought steel or wrought iron pipe of standard weight, and

6.6.1.2 Have a time constant in the range from 6.0 to 7.2 min while encased in the tubes described in 6.6.1.1.

NOTE 2—A typical thermocouple assembly meeting these time constant requirements may be fabricated by fusion-welding the twisted ends of No. 18 gage Chromel-Alumel wires, mounting the leads in porcelain insulators, and inserting the assembly so the thermocouple bead is 0.5 in. (25 mm) from the sealed end of the standard weight nominal 1/2-in. iron, steel, or Inconel⁶ pipe. The time constant for this and for several other thermocouple assemblies was measured in 1976. The time constant may also be calculated from knowledge of its physical and thermal properties.⁷

6.6.2 Other types of protection tubes or pyrometers are permitted to be used provided that under test conditions they give the same indications as those of 6.6.1 within the limit of accuracy that applies for furnace-temperature measurements.

6.7 Cotton Wool Pads:

6.7.1 The cotton wool pads shall:

6.7.1.1 Measure 4 ± 0.125 in. (100 ± 3 mm) long by 4 ± 0.125 in. (100 ± 3 mm) wide by 0.85 ± 0.0625 in. (20 ± 2 mm) thick,

6.7.1.2 Consist only of new undyed soft cotton fibers, without any admixture of artificial fibers,

6.7.1.3 Have a mass between 3 and 4 g, and

6.7.1.4 Be attached using wire clips to a wire frame. The frame used to hold the cotton wool pad is to be formed of steel wire (typically No. 15 AWG (1.5 mm)) and is to be provided with a handle long enough to reach all points of the test assembly. See Fig. 5.

6.7.1.5 The cotton wool pads are to be conditioned prior to use by drying in an oven at 212 ± 9°F (100 ± 5°C) for at least 30 min. After drying, the cotton wool pads shall be stored in a desiccator until they are used.

7. Time-Temperature Curve

7.1 The fire exposure of door assemblies shall be controlled to conform to the applicable portion of the standard time-temperature curve shown in Fig. 6 (see X1.7). The points on the curve that determine its character are as follows:

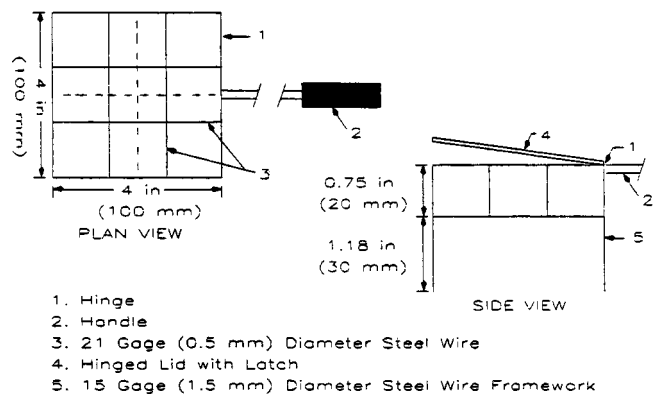

NOTE 1: Solid lines illustrate the framework.
NOTE 2: Dashed lines illustrate the hinged lid.

FIG. 5 Example of a Typical Cotton Wool Pad Holder

⁶ Inconel is a registered trade name of INCO Alloys, Inc., 3800 Riverside Dr., Huntington, WV 25720.

⁷ Supporting data is available from ASTM Headquarters. Request RR:E05-1001.

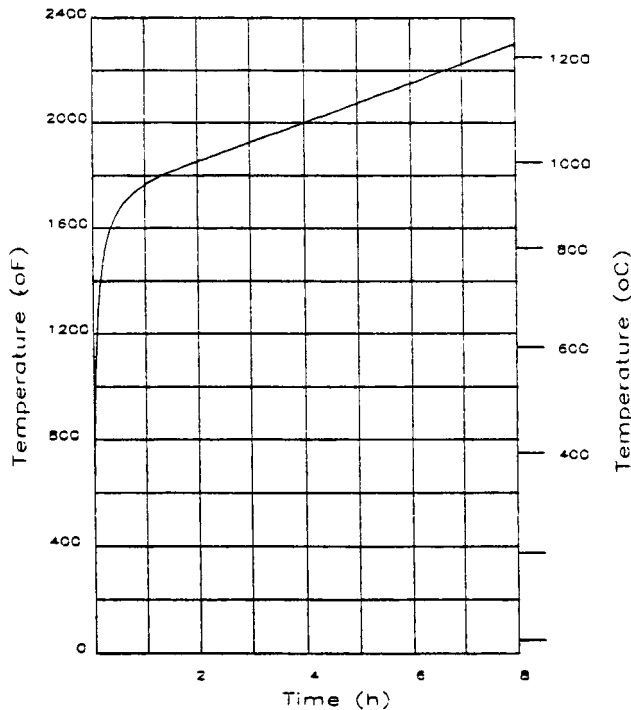

FIG. 6 Standard Time-Temperature Curve

1000°F (638°C)	at 5 min
1300°F (704°C)	at 10 min
1550°F (843°C)	at 30 min
1700°F (926°C)	at 1 h
1850°F (1010°C)	at 2 h
2000°F (1093°C)	at 4 h
2300°F (1260°C)	at 8 h or over

7.1.1 For a more detailed definition of the time-temperature curve, refer to Table 1.

7.1.2 The temperature inside the furnace recorded at the start of the test shall be considered ambient.

8. Furnace Temperatures

8.1 The temperatures of the test exposure shall be deemed to be the average temperature obtained from the readings of not less than nine thermocouples symmetrically disposed and distributed to show the temperature near all parts of the test assembly.

8.2 Originally locate the junction of the thermocouples 6 ± 0.25 in. (152 ± 6 mm) from the exposed face of the test assembly or from the construction in which the assembly is installed.

8.2.1 Verify the distance established in 8.2 at intervals not exceeding 10 min during the first 30 min of the test and thereafter at intervals not exceeding 30 min.

8.2.2 Whenever the distance is not as specified in 8.2, reset the distance to comply with 8.2.

8.3 The furnace temperatures shall be measured and recorded at intervals not exceeding 1 min.

8.4 The accuracy of the furnace control shall be such that the area under the time-temperature curve, obtained by averaging the results from the thermocouple readings, is within 10 % of the corresponding area under the standard time-temperature curve for fire tests of 1-h or less duration, within

TABLE 1 Standard Time-Temperature Curve for Control of Fire Tests

Time, h/min	Temperature, °F	Area Above 68°F base		Temperature, °C	Area Above 20°C base	
		°F·min	°F·h		°C·min	°C·h
0:00	68	0	0	20	0	0
0:05	1 000	2 330	39	538	1 290	22
0:10	1 300	7 740	129	704	4 300	72
0:15	1 399	14 150	236	760	7 860	131
0:20	1 462	20 970	350	795	11 650	14
0:25	1 510	28 050	468	821	15 590	260
0:30	1 550	35 360	589	843	19 650	328
0:35	1 584	42 860	714	862	23 810	397
0:40	1 613	50 510	842	878	28 060	468
0:45	1 638	58 300	971	892	32 390	540
0:50	1 661	66 200	1 103	905	36 780	613
0:55	1 681	74 220	1 237	916	41 230	687
1:00	1 700	82 330	1 372	927	45 740	762
1:05	1 718	90 540	1 509	937	50 300	838
1:10	1 735	98 830	1 647	946	54 910	915
1:15	1 650	107 200	1 787	955	59 560	993
1:20	1 765	115 650	1 928	963	64 250	1 071
1:25	1 779	124 180	2 070	971	68 990	1 150
1:30	1 792	132 760	2 213	978	73 760	1 229
1:35	1 804	141 420	2 357	985	78 560	1 309
1:40	1 815	150 120	2 502	991	83 400	1 390
1:45	1 826	158 890	2 648	996	88 280	1 471
1:50	1 835	167 700	2 795	1 001	93 170	1 553
1:55	1 843	176 550	2 942	1 006	98 080	1 635
2:00	1 850	185 440	3 091	1 010	103 020	1 717
2:10	1 862	203 330	3 389	1 017	112 960	1 882
2:20	1 875	221 330	3 689	1 024	122 960	2 049
2:30	1 888	239 470	3 991	1 031	133 040	2 217
2:40	1 900	257 720	4 295	1 038	143 180	2 386
2:50	1 912	276 110	4 602	1 045	153 390	2 556
3:00	1 925	294 610	4 910	1 052	163 670	2 728
3:10	1 938	313 250	5 221	1 059	174 030	2 900
3:20	1 950	332 000	5 533	1 066	184 450	3 074
3:30	1 962	350 890	5 848	1 072	194 940	3 249
3:40	1 975	369 890	6 165	1 079	205 500	3 425
3:50	1 988	389 030	6 484	1 086	216 130	3 602
4:00	2 000	408 280	6 805	1 093	226 820	3 780
4:10	2 012	427 670	7 128	1 100	237 590	3 960
4:20	2 025	447 180	7 453	1 107	248 430	4 140
4:30	2 038	466 810	7 780	1 114	259 340	4 322
4:40	2 050	486 560	8 110	1 121	270 310	4 505
4:50	2 062	506 450	8 441	1 128	281 360	4 689
5:00	2 075	526 450	8 774	1 135	292 470	4 874
5:10	2 088	546 580	9 110	1 142	303 660	5 061
5:20	2 100	566 840	9 447	1 149	314 910	5 248
5:30	2 112	587 220	9 787	1 156	326 240	5 437
5:40	2 125	607 730	10 129	1 163	337 630	5 627
5:50	2 138	628 360	10 473	1 170	349 090	5 818
6:00	2 150	649 120	10 819	1 177	360 620	6 010
6:10	2 162	670 000	11 167	1 184	372 230	6 204
6:20	2 175	691 010	11 517	1 191	383 900	6 398
6:30	2 188	712 140	11 869	1 198	395 640	6 594
6:40	2 200	733 400	12 223	1 204	407 450	6 791
6:50	2 212	754 780	12 580	1 211	419 330	6 989
7:00	2 225	776 290	12 938	1 218	431 270	7 188
7:10	2 238	797 920	13 299	1 225	443 290	7 388
7:20	2 250	819 680	13 661	1 232	455 380	7 590
7:30	2 262	841 560	14 026	1 239	467 540	7 792
7:40	2 275	863 570	14 393	1 246	479 760	7 996
7:50	2 288	885 700	14 762	1 253	492 060	8 201
8:00	2 300	907 960	15 133	1 260	504 420	8 407

7.5 % for those over 1 h and not more than 2 h, and within 5 % for tests exceeding 2 h in duration.

9. Unexposed Surface Temperatures and Cotton Wool Pad Application

9.1 Unexposed surface temperatures (see X1.9) shall be measured, recorded, and determined in the following manner:

9.1.1 Unexposed surface temperatures shall be taken at not less than three points with at least one thermocouple in each 16-ft²(1.5-m²) area of the door assembly. Thermocouples shall not be located over reinforcements extending through the door assembly, over vision panels, or nearer than 12 in. (305 mm) from the edge of the door assembly.

9.1.2 Unexposed surface temperatures shall be measured with copper disk thermocouples placed under dry felted pads, both meeting the requirements of 6.2. The pads shall be held firmly against the surface of the door assembly and fit closely about the thermocouples.

9.1.3 Unexposed surface temperatures shall be measured and recorded at intervals not exceeding 1 min.

9.1.4 When requested by the test sponsor, remove the copper disk thermocouples and pads after the first 30 min of the test and cease recording unexposed surface temperatures.

9.2 *Cotton Wool Pad Application*—When the average unexposed surface temperature of a door assembly is less than 650°F (343°C) during the first 30 min of the test, evaluate the integrity of the test assembly during the fire endurance test using a cotton wool pad in a wire frame provided with a handle. The passage of flames and hot gases, through cracks, holes, or other openings in the test assembly that have developed due to the fire test exposure, shall be determined by applying a cotton wool pad to such openings at intervals not exceeding 2 min during the test. The cotton wool pad shall comply with 6.7 and the following:

9.2.1 Be held in place for a minimum of 20 s, but not more than 30 s,

9.2.2 Be located 1 ± 0.25 in. (25 ± 5 mm) away from and centered above such openings,

9.2.3 Shall not come in contact with the surface of the test assembly,

9.2.4 Shall not be reused if it has charred during a previous application or if it has absorbed any moisture, and

9.2.5 When no ignition (defined as glowing or flaming) of the cotton wool pad occurs during the minimum 20-s application, make screening tests that involve: (1) short-duration applications of the cotton wool pad to areas of potential failure or (2) the movement of a single pad over and around such areas, or both. Charring of the pad only provides an indication of imminent failure. Employ a previously unused cotton wool pad for an integrity failure to be confirmed.

10. Furnace Pressure

10.1 The pressure in the furnace shall be measured using pressure-sensing probes which comply with 6.3.

10.2 The pressure in the furnace shall be measured using at least two probes located within the furnace and separated by a vertical distance of at least 6 ft (1.8 m) (see X1.12). It is permitted to reduce the vertical separation to 3 ft (0.9 m) when one of the pressure probes is located 40 in. above the sill.

10.3 Locate the probes as near to the vertical centerline of the furnace opening as practical.

10.4 Use a differential pressure measurement instrument which complies with 6.4 to measure the pressure. Locate the differential pressure measurement instrument to minimize the “stack” effects caused by vertical runs of pressure tubing between the furnace probe and instrument locations.

11. Test Assemblies

11.1 Construction and Size:

11.1.1 Make the door assembly full size. Make the construction and size of the door assembly, consisting of single doors, doors in pairs, special-purpose doors (such as Dutch doors, double-egress doors, and so forth), or multi-section doors, representative of that for which a fire endurance rating is desired (see X1.10).

11.1.2 Provide a floor structure as part of the opening to be protected, except where such floor interferes with the operation of the door. Construct the floor segment of noncombustible material and project it into the furnace approximately twice the thickness of the test door assembly, or to the limit of the frame, whichever is greater.

NOTE 3—See Terminology E 176 for the definition of “noncombustible.”

11.1.3 Fire test asymmetrical door assemblies from both sides unless the door assembly is designed and designated for fire exposure from only one side or it is determined and documented in the report by the laboratory that the side being tested represents the more onerous condition.

NOTE 4—It is permitted to install more than one door assembly into the test wall assembly to simultaneously test more than one door assembly or both sides of one door assembly.

11.2 Installation:

11.2.1 Place the door assembly in a wall. Make the wall in which the door assembly is to be tested adequate to retain the door assembly throughout the fire and hose stream test and constructed of masonry or other materials representative of wall construction.

11.2.2 When used, ensure the door frame anchors are suitable for wall construction.

11.2.3 Install all doors such that they fit within their frame, against the wall surfaces, or in guides, but do not allow such installation to prevent free and easy operation of the test door (see X1.11).

11.2.3.1 Install sliding and rolling doors, except horizontal slide-type elevator shaft doors, on the exposed side of the opening in the wall closing the furnace chamber.

11.2.3.2 Install horizontal slide-type elevator shaft doors on the unexposed side of the opening in the wall closing the furnace chamber.

11.2.3.3 Install access-type doors and chute-type doors and frame assemblies so as to have one assembly open into the furnace chamber and another assembly open away from the furnace chamber.

11.2.3.4 Install dumbwaiter and service-counter doors and frame assemblies on the exposed side of the opening in the wall.

11.2.4 After the door frames are installed, verify that the doors open either away from or into the furnace chamber, as required by the laboratory, to obtain representative information on the performance of the construction under test.

11.2.5 Evaluate surface-installed fire-exit hardware for use on the fire doors under conditions in which it is installed in one