



SLOVENSKI STANDARD

SIST EN 13540:2003

01-februar-2003

I gb^Y!':]n_Ub]']b'a Y Ubg_]dfYg_i g]!'CXdcfbcgh`U_UghY[Ui gb^Udfch]j fc]b]

Leather - Physical and mechanical tests - Determination of heat resistance of patent leather

Leder - Physikalische und mechanische Prüfungen - Wärmebeständigkeit von Lackleder

Cuir - Essais physiques et mécaniques - Détermination de la résistance a la chaleur des cuirs vernis

iTeh STANDARD PREVIEW
(standards.iteh.ai)

Ta slovenski standard je istoveten z: ^{SIST EN 13540:2003} EN 13540:2002

<https://standards.iteh.ai/catalog/standards/sist/c6967d27-2cf3-472f-aa12-9ebd0d0862dd/sist-en-13540-2003>

ICS:

59.140.30 Usnje in krzno Leather and furs

SIST EN 13540:2003 en

iTeh STANDARD PREVIEW
(standards.iteh.ai)

[SIST EN 13540:2003](#)

<https://standards.iteh.ai/catalog/standards/sist/c6967d27-2c3b-472f-aa12-9ebd0d0862dd/sist-en-13540-2003>

EUROPEAN STANDARD

EN 13540

NORME EUROPÉENNE

EUROPÄISCHE NORM

December 2002

ICS 59.140.30

English version

Leather - Physical and mechanical tests - Determination of heat resistance of patent leather

Cuir - Essais physiques et mécaniques - Détermination de la résistance à la chaleur des cuirs vernis

Leder - Physikalische und mechanische Prüfungen - Wärmebeständigkeit von Lackleder

This European Standard was approved by CEN on 24 October 2002.

CEN members are bound to comply with the CEN/CENELEC Internal Regulations which stipulate the conditions for giving this European Standard the status of a national standard without any alteration. Up-to-date lists and bibliographical references concerning such national standards may be obtained on application to the Management Centre or to any CEN member.

This European Standard exists in three official versions (English, French, German). A version in any other language made by translation under the responsibility of a CEN member into its own language and notified to the Management Centre has the same status as the official versions.

CEN members are the national standards bodies of Austria, Belgium, Czech Republic, Denmark, Finland, France, Germany, Greece, Iceland, Ireland, Italy, Luxembourg, Malta, Netherlands, Norway, Portugal, Spain, Sweden, Switzerland and United Kingdom.

[SIST EN 13540:2003](https://standards.iteh.ai/catalog/standards/sist/c6967d27-2c3b-472f-aa12-9ebd0d0862dd/sist-en-13540-2003)

<https://standards.iteh.ai/catalog/standards/sist/c6967d27-2c3b-472f-aa12-9ebd0d0862dd/sist-en-13540-2003>



EUROPEAN COMMITTEE FOR STANDARDIZATION
COMITÉ EUROPÉEN DE NORMALISATION
EUROPÄISCHES KOMITEE FÜR NORMUNG

Management Centre: rue de Stassart, 36 B-1050 Brussels

Contents

	page
Foreword.....	3
1 Scope	4
2 Normative references	4
3 Method A - Lastometer method	4
3.1 Principle	4
3.2 Apparatus	4
3.3 Sampling and sample preparation	5
3.4 Procedure	5
3.5 Test Report	5
4 Method B - Zwik method	6
4.1 Principle	6
4.2 Apparatus	6
4.3 Sampling and sample preparation	7
4.4 Procedure	8
4.5 Test Report	8
Annex A (informative) Sources of apparatus for Method A	9
Annex B (informative) Sources of apparatus for Method B	10

[SIST EN 13540:2003](https://standards.iteh.ai/catalog/standards/sist/c6967d27-2c3b-472f-aa12-9ebd0d0862dd/sist-en-13540-2003)
<https://standards.iteh.ai/catalog/standards/sist/c6967d27-2c3b-472f-aa12-9ebd0d0862dd/sist-en-13540-2003>

Foreword

This document (EN 13540:2002) has been prepared by Technical Committee CEN/TC 289, "Leather", the secretariat of which is held by UNI.

This European Standard shall be given the status of a national standard, either by publication of an identical text or by endorsement, at the latest by June 2003, and conflicting national standards shall be withdrawn at the latest by June 2003.

Annexes A and B are informative.

According to the CEN/CENELEC Internal Regulations, the national standards organizations of the following countries are bound to implement this European Standard: Austria, Belgium, Czech Republic, Denmark, Finland, France, Germany, Greece, Iceland, Ireland, Italy, Luxembourg, Malta, Netherlands, Norway, Portugal, Spain, Sweden, Switzerland and the United Kingdom.

iTeh STANDARD PREVIEW (standards.iteh.ai)

[SIST EN 13540:2003](https://standards.iteh.ai/catalog/standards/sist/c6967d27-2c3b-472f-aa12-9ebd0d0862dd/sist-en-13540-2003)

<https://standards.iteh.ai/catalog/standards/sist/c6967d27-2c3b-472f-aa12-9ebd0d0862dd/sist-en-13540-2003>

EN 13540:2002 (E)**1 Scope**

This European Standard specifies two methods for determining the heat resistance of patent leather. Method A makes use of a modified lastometer whilst Method B uses the 'Zwik' apparatus. Both methods are applicable to patent leathers for all end uses.

2 Normative references

This European Standard incorporates by dated or undated reference, provisions from other publications. These normative references are cited at the appropriate places in the text and the publications are listed hereafter. For dated references, subsequent amendments to or revisions of any of these publications apply to this European Standard only when incorporated in it by amendment or revision. For undated references the latest edition of the publication referred to applies (including amendments).

prEN ISO 2418, *Leather - Chemical, physical and mechanical and fastness tests - Sampling location (ISO/FDIS 2418:2001)*

prEN ISO 2419, *Leather - Physical and mechanical tests - Sample preparation and conditioning (ISO/FDIS 2419:2001)*

3 Method A - Lastometer method**3.1 Principle**

A perforated test piece is distended by a specified amount. The surface is heated and any damage to the patent finish is noted.

iTeh STANDARD PREVIEW
(standards.iteh.ai)

3.2 Apparatus

SIST EN 13540:2003

<https://standards.iteh.ai/catalog/standards/sist/c6967d27-2c3b-472f-aa12->

3.2.1 A test machine, including the parts described in 3.2.1.1 to 3.2.1.4.

3.2.1.1 Clamp, capable of holding the test piece around its edge leaving free a central circular area of diameter 25,0 mm \pm 0,1 mm. The design of its clamping system shall ensure that the test piece does not slip under the test conditions and neither stretches nor compresses the central area as it is clamped. The boundary between the free and clamped area shall be sharply defined.

3.2.1.2 Plunger, terminating in a steel ball of diameter 21,0 mm \pm 0,1 mm.

3.2.1.3 Mechanism for thrusting the steel ball, without rotation against the test specimen.

3.2.1.4 Mechanism for monitoring the distension of the steel ball, (travel from zero) to an accuracy of \pm 0,05 mm.

3.2.2 Press knife, conforming to the requirements of prEN ISO 2419 for cutting test pieces of suitable dimensions for the test machine.

3.2.3 Sewing machine needle, sharp and undamaged, PCL size 80, either fitted into holder suitable for use by hand or into sewing machine.

NOTE Other sized needles may be used if they are more appropriate to the sewing used in the shoe production.

3.2.4 Hot air blower, capable of maintaining a temperature of 100 °C \pm 5 °C or 125 °C \pm 5 °C.

3.2.5 Temperature measuring device, reading to 1 °C.

3.2.6 Stopwatch, reading to 1s.

3.2.7 Soft rubber mats, minimum thickness 10 mm.

3.3 Sampling and sample preparation

3.3.1 Sample in accordance with prEN ISO 2418. Cut 3 test pieces by applying the press knife (3.2.2) to the patent surface.

NOTE If there is a requirement for more than two hides or skins to be tested in one batch, then only one sample need be taken from each hide or skin, provided that the overall total is not less than three test pieces.

3.3.2 If the test piece is to be perforated by hand place the test piece on the soft rubber mat (3.2.7) with the patent surface uppermost. Using the sewing machine needle fitted into a holder (3.2.3) pierce a hole vertically through the centre of the test piece so that the hole is within 1,0 mm of the centre. Pierce four further holes through the test piece with each hole 5,0 mm \pm 0,5 mm from the first hole so that the first holes form a simple (Greek) cross. Ensure that the needle penetrates through the leather into the soft rubber mat.

3.3.3 If the test piece is to be perforated by machine perforate through the centre using the needle fitted into a sewing machine (3.2.3) running at normal speed but without the thread and set at 6 stitches/10 mm.

3.3.4 Condition the test piece in accordance with prEN ISO 2419. Carry out the test in the standard atmosphere.

3.4 Procedure

3.4.1 Set the instrument so that the plunger is set at zero or minimum distension.

3.4.2 Tightly clamp the test piece into the instrument so that the ball end of the plunger (3.2.1.2) acts on the reverse side of the test piece.

3.4.3 Force the ball end of the plunger into the test piece until the test piece is distended by 7,5 mm \pm 0,05 mm as shown on the distension scale (3.2.1.4). Examine the test piece and note any damage.

3.4.4 Place the sensor of the temperature measuring device (3.2.5) a distance of 1,5 mm \pm 0,5 mm above the dome of the distended test piece. Using the hot air blower (3.2.4) raise the temperature of the test piece to 100 °C \pm 5 °C or 125 °C \pm 5 °C as indicated on the temperature measuring device (3.2.5) and maintain this temperature for 180 s \pm 5 s or 300 s \pm 5 s respectively. If the temperature goes out of the limits reject the test piece and repeat using a fresh test piece.

3.4.5 Maintain the test piece in the distended state and re-examine. Record any damage to the patent finish or the leather grain.

3.4.6 Repeat steps 3.4.1 to 3.4.5 for the remaining test pieces.

3.5 Test Report

The test report shall include the following:

- a) reference to this European Standard; i.e. EN 13540 : 2002
- b) details of any damage to the patent finish or leather grain when the test piece is first distended;
- c) details of any damage to the patent finish or leather grain when the test piece is heated;
- d) the test temperature and time (i.e. 100 °C for 180 s or 125 °C for 300 s);
- e) the standard atmosphere used for conditioning and testing as given in prEN ISO 2419 (i.e. 20 °C/65 % rh, or 23 °C/50 % rh);
- f) any deviations from the method specified in this European standard;

EN 13540:2002 (E)

g) full details for identification of the sample and any deviations from prEN ISO 2418 with respect to sampling.

4 Method B - Zwik method**4.1 Principle**

A perforated test piece is distended by a specified amount. The surface is heated and any damage to the patent finish is noted.

4.2 Apparatus

4.2.1 Test machine, constructed such that the two ends of the test piece are held in the fixed horizontal clamp B, so that the test piece can be stretched over mandrel D. Mandrel D consists of a horizontal half cylinder of radius 15,0 mm \pm 0,1 mm and length 25,5 mm \pm 0,1 mm with a quarter sphere of radius 15,0 mm \pm 0,1 mm at its end. The lower (fixed) face of clamp A is in the same plane as the top line of mandrel D and clamp B is 11,0 mm \pm 0,1 mm vertically below the curved tip of the mandrel.

The hand operated lever C to which clamp B is attached moves up and down in a quadrant E. Its maximum downward movement, which determines the maximum stretch of the test piece, is controlled by a pin which passes through two holes in the two sides of the quadrant. There are pairs of holes in the quadrant, and the pin can be inserted through any of these to control the amount of movement of the lever. One setting shall correspond to a linear extension of the test piece of 21% \pm 1%. A lock (G) enables the lever to be held at its highest position at the top of the quadrant.

The general arrangement of the test machine is shown in Figure 1.

iTeh STANDARD PREVIEW
(standards.iteh.ai)

4.2.2 Press knife, conforming to the requirements of prEN ISO 2419, the inner wall of which is a rectangle 95 mm \pm 1 mm x 50 mm \pm 1 mm.

[SIST EN 13540:2003](#)

4.2.3 Sewing machine, fitted with sharp, undamaged needle PCL size 80.

<https://standards.iteh.ai/catalog/standards/sist/6967d27-2cB-472f-aa12-9ebd0d0862dd/sist-en-13540-2003>

NOTE Other sized needles may be used if they are more appropriate to the sewing used in the shoe production.

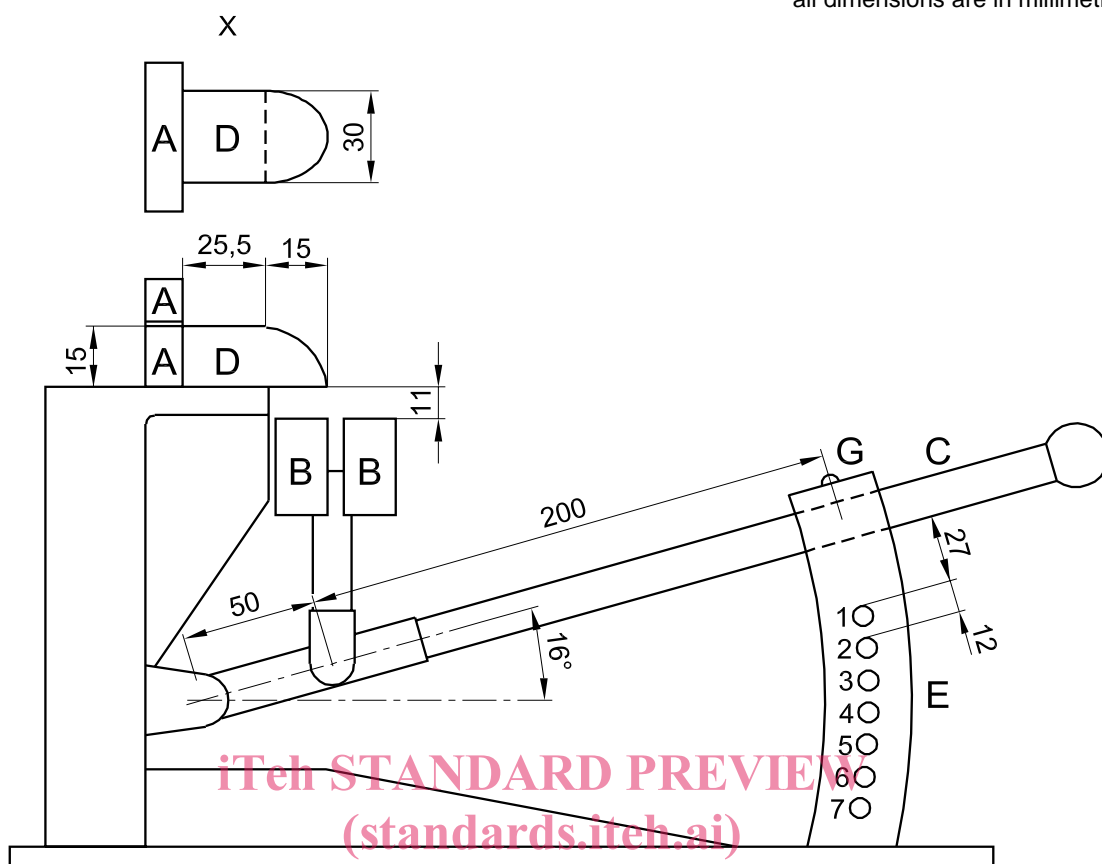
all dimensions are in millimetres $\pm 0,1$ mm**Key**

SIST EN 13540:2003

X Plan view of Mandrel D <https://standards.iteh.ai/catalog/standards/sist/c6967d27-2c3b-472f-aa12-9ebd0d0862dd/sist-en-13540-2003>**Figure 1 — General arrangement of the test machine**

4.2.4 Hot air blower, capable maintaining a temperature $125\text{ °C} \pm 5\text{ °C}$.

4.2.5 Temperature measuring device, reading to 1 °C .

4.2.6 Stopwatch, reading to 1s.

4.3 Sampling and sample preparation

4.3.1 Sample in accordance with prEN ISO 2418. Cut 6 test pieces by applying the press knife (4.2.2) to the patent surface. Cut three test pieces with the long edge parallel to the backbone and three with the long edge perpendicular to the backbone.

NOTE If there is a requirement for more than two hides or skins to be tested in one batch, then only one sample in each direction need be taken from each hide or skin, provided that the overall total is not less than three test pieces in each direction.

4.3.2 Perforate the test pieces along the centre line parallel to the longer side with a row of needle holes using the sewing machine (4.2.3) running at its normal speed but without the thread at 6 stitches/10 mm.

4.3.3 Condition the test pieces in accordance with prEN ISO 2419. There is no need to carry out the test in a conditioned atmosphere.