

INTERNATIONAL STANDARD

ISO 7575

Second edition
1993-06-15

Commercial road vehicles — Flat attachment wheel fixing nuts

iTeh STANDARD PREVIEW
Véhicules utilitaires — Écrous de fixation des roues à attache plate
(standards.iteh.ai)

ISO 7575:1993

<https://standards.iteh.ai/catalog/standards/sist/cf47846c-38bc-4244-abbe-087052776826/iso-7575-1993>



Reference number
ISO 7575:1993(E)

Foreword

ISO (the International Organization for Standardization) is a worldwide federation of national standards bodies (ISO member bodies). The work of preparing International Standards is normally carried out through ISO technical committees. Each member body interested in a subject for which a technical committee has been established has the right to be represented on that committee. International organizations, governmental and non-governmental, in liaison with ISO, also take part in the work. ISO collaborates closely with the International Electrotechnical Commission (IEC) on all matters of electrotechnical standardization.

Draft International Standards adopted by the technical committees are circulated to the member bodies for voting. Publication as an International Standard requires approval by at least 75 % of the member bodies casting a vote.

International Standard ISO 7575 was prepared by Technical Committee ISO/TC 22, *Road vehicles*, Sub-Committee SC 19, *Wheels*.

This second edition cancels and replaces the first edition (ISO 7575:1984). Dimensions for the hexagon flat in figure 1 and table 1 are new.

© ISO 1993

All rights reserved. No part of this publication may be reproduced or utilized in any form or by any means, electronic or mechanical, including photocopying and microfilm, without permission in writing from the publisher.

International Organization for Standardization
Case Postale 56 • CH-1211 Genève 20 • Switzerland

Printed in Switzerland

Commercial road vehicles — Flat attachment wheel fixing nuts

iTeh STANDARD PREVIEW (standards.iteh.ai)

[ISO 7575:1993](#)

<https://standards.iteh.ai/catalog/standards/sist/cf47846c-38bc-4244-abbe-087052776826/iso-7575-1993>

1 Scope

This International Standard specifies the essential dimensions of hexagon nuts with a flat seat captive washer for 18 mm, 20 mm and 22 mm studs.

It applies to nuts designed for fixing flat attachment wheels with centring on a central bore, the dimensions of which are specified in ISO 4107.

2 Normative reference

The following standard contains provisions which, through reference in this text, constitute provisions of this International Standard. At the time of publication, the edition indicated was valid. All standards are subject to revision, and parties to agreements based on this International Standard are encouraged

to investigate the possibility of applying the most recent edition of the standard indicated below. Members of IEC and ISO maintain registers of currently valid International Standards.

ISO 4107:1979, *Road vehicles — Wheels for commercial vehicles — Dimensional characteristics of attachment on hub.*

3 Dimensions

Dimensions and tolerances shall be as specified in figure 1 and table 1.

Only the dimensions necessary to ensure interchangeability are specified. The nut technology, and particularly the design of the nut relative to the washer, is left to the manufacturer.

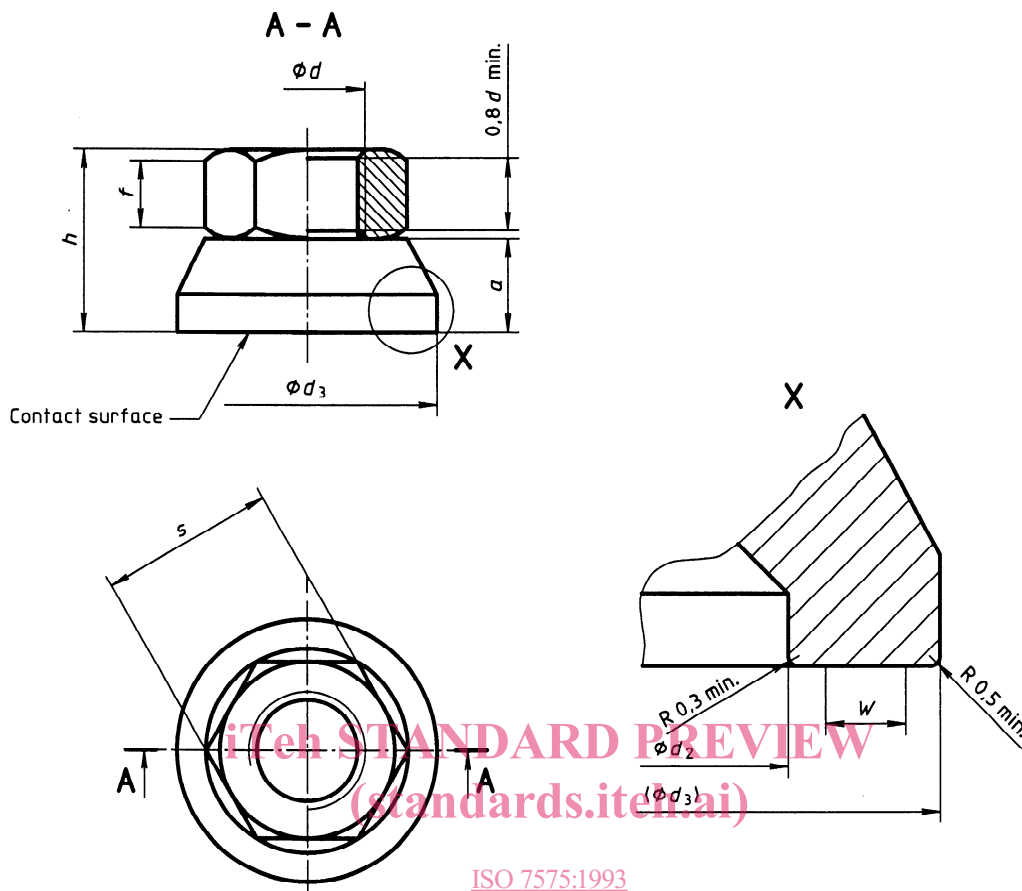

ISO 7575:1993
<https://standards.iteh.ai/catalog/standards/sist/cf47846c-38bc-4244-abbe-087052776826/iso-7575-1993>

Figure 1

Table 1

Dimensions in millimetres

Thread ¹⁾	Width across flats	Inner diameter of washer	Outer diameter of washer	Radial width of flat contact surface	Overall height of nut and washer ²⁾	Distance between contact surface of washer to start of thread	Hex flat
d	s h13	d_2 min.	d_3 max.	W min.	h max.	a min.	f min.
M18 × 1,5	27	23	40	5	27	4,5	10,5
M20 × 1,5	30	26	45	5,5	29	4,5	11
M22 × 1,5	33	28	49	6	34	4,5	12,5

- 1) The effective thread length shall be 0,8d min. (See figure 1.)
- 2) The overall width of the vehicle may demand significantly lower values of h .

iTeh STANDARD PREVIEW
(standards.iteh.ai)

This page intentionally left blank

[ISO 7575:1993](#)

<https://standards.iteh.ai/catalog/standards/sist/cf47846c-38bc-4244-abbe-087052776826/iso-7575-1993>

iTeh STANDARD PREVIEW
(standards.iteh.ai)

This page intentionally left blank

[ISO 7575:1993](#)

<https://standards.iteh.ai/catalog/standards/sist/cf47846c-38bc-4244-abbe-087052776826/iso-7575-1993>

iTeh STANDARD PREVIEW
(standards.iteh.ai)

This page intentionally left blank

[ISO 7575:1993](#)

<https://standards.iteh.ai/catalog/standards/sist/cf47846c-38bc-4244-abbe-087052776826/iso-7575-1993>

iTeh STANDARD PREVIEW
(standards.iteh.ai)

ISO 7575:1993

<https://standards.iteh.ai/catalog/standards/sist/cf47846c-38bc-4244-abbe-087052776826/iso-7575-1993>

UDC 629.11.012.323:629.114.4

Descriptors: road vehicles, commercial road vehicles, vehicle wheels, fastenings, nuts (fasteners), hexagonal nuts, dimensions.

Price based on 2 pages
