

INTERNATIONAL STANDARD

**ISO
7576**

Second edition
1990-07-15

Road vehicles — Two-stage fuel filters for compression-ignition engines — Mounting and connecting dimensions

iTeh STANDARD PREVIEW
(standards.iteh.ai)

*Véhicules routiers — Filtres à combustible à deux étages pour moteurs à
combustion interne à allumage par compression — Dimensions de montage et de
raccordement*

ISO 7576:1990

[https://standards.iteh.ai/catalog/standards/sist/4513b5da-3ba2-4ee3-bc4c-
e579b9aa86f0/iso-7576-1990](https://standards.iteh.ai/catalog/standards/sist/4513b5da-3ba2-4ee3-bc4c-e579b9aa86f0/iso-7576-1990)



Reference number
ISO 7576 : 1990 (E)

Foreword

ISO (the International Organization for Standardization) is a worldwide federation of national standards bodies (ISO member bodies). The work of preparing International Standards is normally carried out through ISO technical committees. Each member body interested in a subject for which a technical committee has been established has the right to be represented on that committee. International organizations, governmental and non-governmental, in liaison with ISO, also take part in the work. ISO collaborates closely with the International Electrotechnical Commission (IEC) on all matters of electrotechnical standardization.

Draft International Standards adopted by the technical committees are circulated to the member bodies for voting. Publication as an International Standard requires approval by at least 75 % of the member bodies casting a vote.

International Standard ISO 7576 was prepared by Technical Committee ISO/TC 22, *Road vehicles*.

This second edition cancels and replaces the first edition (ISO 7576:1982), of which it constitutes a minor revision.

Annex A of this International Standard is for information only.

Road vehicles — Two-stage fuel filters for compression-ignition engines — Mounting and connecting dimensions

iTeh STANDARD PREVIEW
(standards.iteh.ai)

1 Scope

This International Standard specifies the mounting and connecting dimensions for two-stage fuel filters used for compression-ignition (diesel) engines on road vehicles.

2 Dimensions and tolerances

Dimensions and tolerances shall be in accordance with figure 1 and table 1.

Dimensions in millimetres

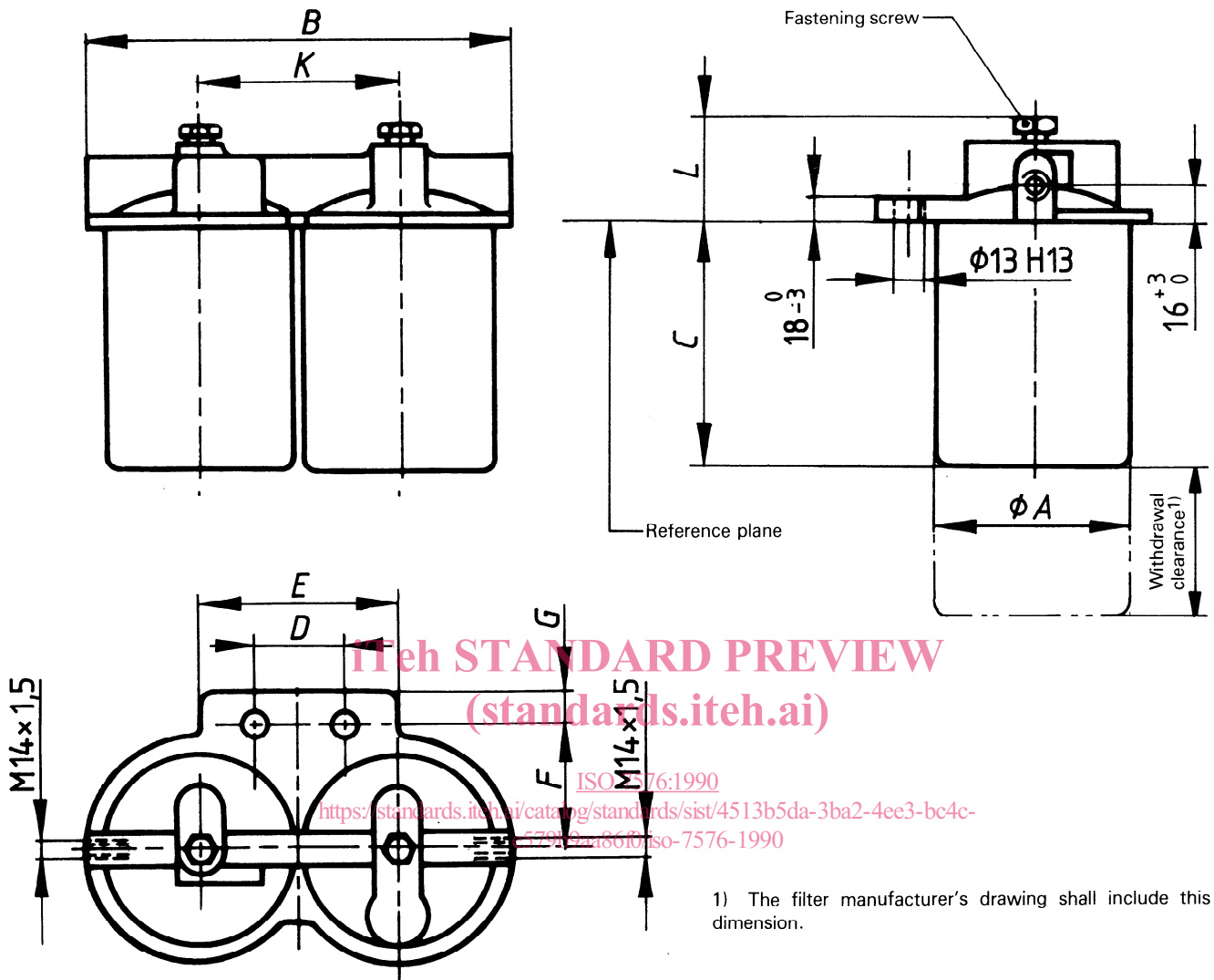

ITeH STANDARD PREVIEW
(standards.iteh.ai)

ISO 7576:1990

<https://standards.iteh.ai/catalog/standards/sist/4513b5da-3ba2-4ee3-bc4c-57912a486f0/iso-7576-1990>

1) The filter manufacturer's drawing shall include this dimension.

Figure 1

Table 1

Dimensions in millimetres

Size	A max.	B max.	C max.	D $\pm 0,2$	E max.	F $+2\ /0$	G max.	K ± 1	L max.
A 2	82	180	75	40	66	55	15	86	42
B 2	82	180	125	40	66	55	15	86	42
C 2	102	223	160	50	106	68	17	107	45

NOTE — Details not specified are left to the manufacturer's choice.

Annex A (informative)

Bibliography

- [1] ISO 7310: 1984, *Road vehicles — Compression ignition engines — Heads for spin-on fuel filters with horizontal flange — Mounting and connecting dimensions.*
- [2] ISO 7311: 1984, *Road vehicles — Compression ignition engines — Heads for fuel filters with vertical flange — Mounting and connecting dimensions.*
- [3] ISO 7577: 1982, *Road vehicles — Heads for fuel filters with vertical flange and three bolt fixing for compression ignition engines — Mounting and connecting dimensions.*
- [4] ISO 7774: 1984, *Road vehicles — Compression ignition engines — Single fuel filters with horizontal flange and centre bolt fixing — Mounting and connecting dimensions.*

iTeh STANDARD PREVIEW
(standards.iteh.ai)

[ISO 7576:1990](https://standards.iteh.ai/catalog/standards/sist/4513b5da-3ba2-4ee3-bc4c-e579b9aa86f0/iso-7576-1990)

<https://standards.iteh.ai/catalog/standards/sist/4513b5da-3ba2-4ee3-bc4c-e579b9aa86f0/iso-7576-1990>

iTeh STANDARD PREVIEW
(standards.iteh.ai)

This page intentionally left blank

[ISO 7576:1990](#)

<https://standards.iteh.ai/catalog/standards/sist/4513b5da-3ba2-4ee3-bc4c-e579b9aa86f0/iso-7576-1990>

iTeh STANDARD PREVIEW
(standards.iteh.ai)

This page intentionally left blank

[ISO 7576:1990](#)

<https://standards.iteh.ai/catalog/standards/sist/4513b5da-3ba2-4ee3-bc4c-e579b9aa86f0/iso-7576-1990>

iTeh STANDARD PREVIEW
(standards.iteh.ai)

ISO 7576:1990

<https://standards.iteh.ai/catalog/standards/sist/4513b5da-3ba2-4ee3-bc4c-e579b9aa86f0/iso-7576-1990>

UDC 621.43.038.772

Descriptors : road vehicles, internal combustion engines, diesel engines, fuel filters, connecting dimensions, dimensional tolerances.

Price based on 3 pages
