



Designation: C 1465 – 00

Standard Test Method for Determination of Slow Crack Growth Parameters of Advanced Ceramics by Constant Stress-Rate Flexural Testing at Elevated Temperatures¹

This standard is issued under the fixed designation C 1465; the number immediately following the designation indicates the year of original adoption or, in the case of revision, the year of last revision. A number in parentheses indicates the year of last reapproval. A superscript epsilon (ϵ) indicates an editorial change since the last revision or reapproval.

1. Scope

1.1 This test method covers the determination of slow crack growth (SCG) parameters of advanced ceramics by using constant stress-rate flexural testing in which flexural strength is determined as a function of applied stress rate in a given environment at elevated temperatures. The strength degradation exhibited with decreasing applied stress rate in a specified environment is the basis of this test method which enables the evaluation of slow crack growth parameters of a material.

NOTE 1—This test method is frequently referred to as “dynamic fatigue” testing (Refs (1-3))² in which the term “fatigue” is used interchangeably with the term “slow crack growth.” To avoid possible confusion with the “fatigue” phenomenon of a material which occurs exclusively under cyclic loading, as defined in Terminology E 1823, this test method uses the term “constant stress-rate testing” rather than “dynamic fatigue” testing.

NOTE 2—In glass and ceramics technology, static tests of considerable duration are called “static fatigue” tests, a type of test designated as stress-rupture (Terminology E 1823).

1.2 This test method is intended primarily to be used for *negligible* creep of test specimens, with specific limits on creep imposed in this test method.

1.3 This test method applies primarily to advanced ceramics that are macroscopically homogeneous and isotropic. This test method may also be applied to certain whisker- or particle-reinforced ceramics that exhibit macroscopically homogeneous behavior.

1.4 This test method is intended for use with various test environments such as air, vacuum, inert, and any other gaseous environments.

1.5 Values expressed in this standard test are in accordance with the International System of Units (SI) and Practice E 380.

1.6 *This standard does not purport to address all of the safety concerns, if any, associated with its use. It is the responsibility of the user of this standard to establish appropriate safety and health practices and determine the applicability of regulatory limitations prior to use.*

2. Referenced Documents

2.1 ASTM Standards:

- C 1145 Terminology of Advanced Ceramics³
- C 1161 Test Method for Flexural Strength of Advanced Ceramics at Ambient Temperature³
- C 1211 Test Method for Flexural Strength of Advanced Ceramics at Elevated Temperatures³
- C 1239 Practice for Reporting Uniaxial Strength Data and Estimating Weibull Distribution Parameters for Advanced Ceramics³
- C 1322 Practice for Fractography and Characterization of Fracture Origins in Advanced Ceramics³
- C 1368 Test Method for Determination of Slow Crack Growth Parameters of Advanced Ceramics by Constant Stress-Rate Flexural Testing at Ambient Temperature³
- E 4 Practices for Force Verification of Testing Machines⁴
- E 6 Terminology Relating to Methods of Mechanical Testing⁴
- E 220 Test Method for Calibration of Thermocouples by Comparison Techniques⁵
- E 230 Specification and Temperature-Electromotive Force (EMF) Tables for Standardized Thermocouples⁵
- E 337 Test Method for Measured Humidity with a Psychrometer (the Measurement of Wet- and Dry-Bulb Temperatures)⁶
- E 380 Practice for Use of International System of Units (SI) (The Modernized Metric System)⁷

¹ This test method is under the jurisdiction of ASTM Committee C-28 on Advanced Ceramics and is the direct responsibility of Subcommittee C28.01 on Properties and Performance.

Current edition approved April 10, 2000. Published July 2000.

² The boldface numbers in parentheses refer to the list of references at the end of this standard.

³ *Annual Book of ASTM Standards*, Vol 15.01.

⁴ *Annual Book of ASTM Standards*, Vol 03.01.

⁵ *Annual Book of ASTM Standards*, Vol 14.03.

⁶ *Annual Book of ASTM Standards*, Vol 11.03.

⁷ *Annual Book of ASTM Standards*, Vol 14.02.

E 1823 Terminology Relating to Fatigue and Fracture Testing⁴

3. Terminology

3.1 *Definitions*—The terms described in Terminologies C 1145, E 6, and E 1823 are applicable to this test method. Specific terms relevant to this test method are as follows:

3.1.1 *advanced ceramic, n*—a highly engineered, high-performance, predominately, nonmetallic, inorganic, ceramic material having specific functional attributes. (C 1145)

3.1.2 *constant stress rate, $\dot{\sigma}$ [FL⁻² t⁻¹], n*—a constant rate of increase of maximum flexural stress applied to a specified beam by using either a constant load or constant displacement rate of a testing machine.

3.1.3 *environment, n*—the aggregate of chemical species and energy that surrounds a test specimen. (E 1150)

3.1.4 *environmental chamber, n*—a container surrounding the test specimen and capable of providing controlled local environmental condition.

3.1.5 *flexural strength, σ_f [FL⁻²], n*—a measure of the ultimate strength of a specified beam specimen in bending determined at a given stress rate in a particular environment.

3.1.6 *flexural strength-stress rate diagram*—a plot of flexural strength as a function of stress rate. Flexural strength and stress rate are both plotted on logarithmic scales.

3.1.7 *flexural strength-stress rate curve*—a curve fitted to the values of flexural strength at each of several stress rates, based on the relationship between flexural strength and stress rate:

$$\log \sigma_f = [1/(n + 1)] \log \dot{\sigma} + \log D \text{ (see Appendix X1)}$$

3.1.7.1 *Discussion*—In the ceramics literature, this is often called a “dynamic fatigue” curve.

3.1.8 *fracture toughness, K_{IC} [FL^{-3/2}], n*—a generic term for measures of resistance to extension of a crack. (E 616)

3.1.9 *inert flexural strength [FL⁻²], n*—a measure of the strength of a specified beam specimen in bending as determined in an appropriate inert condition whereby no slow crack growth occurs.

3.1.9.1 *Discussion*—An inert condition at near room temperature may be obtained by using vacuum, low temperatures, very fast test rates, or any inert media. However, at elevated temperatures, the definition or concept of an inert condition is unclear since temperature itself acts as a degrading environment. It has been shown that for some ceramics one approach to obtain an inert condition (thus, inert strength) at elevated temperatures is to use very fast (ultra-fast) test rates $\geq 3 \times 10^4$ MPa/s, where the time for slow crack growth would be minimized or eliminated (4).

3.1.10 *slow crack growth (SCG), n*—subcritical crack growth (extension) which may result from, but is not restricted to, such mechanisms as environmentally assisted stress corrosion or diffusive crack growth.

3.1.11 *stress intensity factor, K_I [FL^{-3/2}], n*—the magnitude of the ideal-crack-tip stress field (stress-field singularly) subjected to Mode I loading in a homogeneous, linear elastic body. (E 616)

3.1.12 *R-curve, n*—a plot of crack-extension resistance as a function of stable crack extension. (E 616)

3.2 *Definitions of Terms Specific to This Standard:*

3.2.1 *slow crack growth parameters, n and D, n*—the parameters estimated as constants in the flexural strength (in megapascals)-stress rate (in megapascals per second) equation, which represent a measure of susceptibility to slow crack growth of a material (see Appendix X1). For the units of *D*, see 9.3.1.

4. Significance and Use

4.1 For many structural ceramic components in service, their use is often limited by lifetimes that are controlled by a process of slow crack growth. This test method provides the empirical parameters for appraising the relative slow crack growth susceptibility of ceramic materials under specified environments at elevated temperatures. This test method is similar to Test Method C 1368 with the exception that provisions for testing at elevated temperatures are given. Furthermore, this test method may establish the influences of processing variables and composition on slow crack growth as well as on strength behavior of newly developed or existing materials, thus allowing tailoring and optimizing material processing for further modification. In summary, this test method may be used for material development, quality control, characterization, and limited design data generation purposes.

NOTE 3—Data generated by this test method do not necessarily correspond to crack velocities that may be encountered in service conditions. The use of data generated by this test method for design purposes may entail considerable extrapolation and loss of accuracy.

4.2 In this test method, the flexural stress computation is based on simple beam theory, with the assumptions that the material is isotropic and homogeneous, the moduli of elasticity in tension and compression are identical, and the material is linearly elastic. The average grain size should be no greater than one fiftieth (1/50) of the beam thickness.

4.3 In this test method, the test specimen sizes and test fixtures were chosen in accordance with Test Method C 1211, which provides a balance between practical configurations and resulting errors, as discussed in Refs (5, 6). Only the four-point test configuration is used in this test method.

4.4 In this test method, the slow crack growth parameters (*n* and *D*) are determined based on the mathematical relationship between flexural strength and applied stress rate, $\log \sigma_f = [1/(n + 1)] \log \dot{\sigma} + \log D$, together with the measured experimental data. The basic underlying assumption on the derivation of this relationship is that slow crack growth is governed by an empirical power-law crack velocity, $v = A[K_I/K_{IC}]^n$ (see Appendix X1).

NOTE 4—There are various other forms of crack velocity laws which are usually more complex or less convenient mathematically, or both, but may be physically more realistic (7). The mathematical analysis in this test method does not cover such alternative crack velocity formulations.

4.5 In this test method, the mathematical relationship between flexural strength and stress rate was derived based on the assumption that the slow crack growth parameter is at least $n \geq 5$ (1, 8). Therefore, if a material exhibits a very high susceptibility to slow crack growth, that is, $n < 5$, special care should be taken when interpreting the results.

4.6 The mathematical analysis of test results according to the method in 4.4 assumes that the material displays no rising

R-curve behavior, that is, no increasing fracture resistance (or crack-extension resistance) with increasing crack length. It should be noted that the existence of such behavior cannot be determined from this test method. The analysis further assumes that the same flaw types control strength over the entire test range. That is, no new flaws are created, and the flaws that control the strength at the highest stress rate control the strength at the lowest stress rate.

4.7 Slow crack growth behavior of ceramic materials can vary as a function of mechanical, material, thermal, and environmental variables. Therefore, it is essential that test results accurately reflect the effects of specific variables under study. Only then can data be compared from one investigation to another on a valid basis, or serve as a valid basis for characterizing materials and assessing structural behavior.

4.8 The strength of advanced ceramics is probabilistic in nature. Therefore, slow crack growth that is determined from the flexural strengths of a ceramic material is also a probabilistic phenomenon. Hence, a proper range and number of test rates in conjunction with an appropriate number of specimens at each test rate are required for statistical reproducibility and design (2). Guidance is provided in this test method.

NOTE 5—For a given ceramic material/environment system, the SCG parameter n is independent of specimen size although its reproducibility is dependent on the variables previously mentioned. By contrast, the SCG parameter D depends significantly on strength, and thus on specimen size (see Eq X1.7).

4.9 The elevated-temperature strength of a ceramic material for a given test specimen and test fixture configuration is dependent on its inherent resistance to fracture, the presence of flaws, test rate, and environmental effects. Analysis of a fracture surface, fractography, though beyond the scope of this test method, is highly recommended for all purposes, especially to verify the mechanism(s) associated with failure (refer to Practice C 1322).

5. Interferences

5.1 Slow crack growth may be the product of both mechanical and chemical driving forces. The chemical driving force for a given material can strongly vary with the composition and temperature of a test environment. Note that slow crack growth testing is time-consuming. It may take several weeks to complete testing of a typical, advanced ceramic. Because of this long test time, the chemical variables of the test environment must be prevented from changing throughout the tests. Inadequate control of these chemical variables may result in inaccurate strength data and SCG parameters, especially for materials that are sensitive to the environment.

5.2 Significant creep at both higher temperatures and lower test rates results in nonlinearity in stress-strain relations as well as accumulated tensile damage in flexure (9). This, depending on the degree of nonlinearity, may limit the applicability of linear elastic fracture mechanics (LEFM), since the resulting relationship between strength and stress rate derived under constant stress-rate testing condition is based on an LEFM approach with negligible creep (creep strain less than 0.1 %). Therefore, creep should be kept as minimal as possible, as compared to the total strain at failure (see 8.11.2).

5.3 Depending on the degree of SCG susceptibility of a material, the linear relationship between $\log(\text{flexural strength})$ and $\log(\text{applied stress rate})$ (see Appendix X1) may start to deviate at a certain high stress rate, at which slow crack growth diminishes or is minimized due to the extremely short test duration. Strengths obtained at higher stress rates (>1000 MPa/s) may remain unchanged so that a plateau is observed in the plot of strength versus stress rate, see Fig. 1a (4). If the strength data determined in this plateau region are included in the analysis, a misleading estimate of the SCG parameters will be obtained. Therefore, the strength data in the plateau shall be excluded as data points in estimating the SCG parameters of the material. This test method addresses this issue by recommending that the highest stress rate be ≤ 1000 MPa/s.

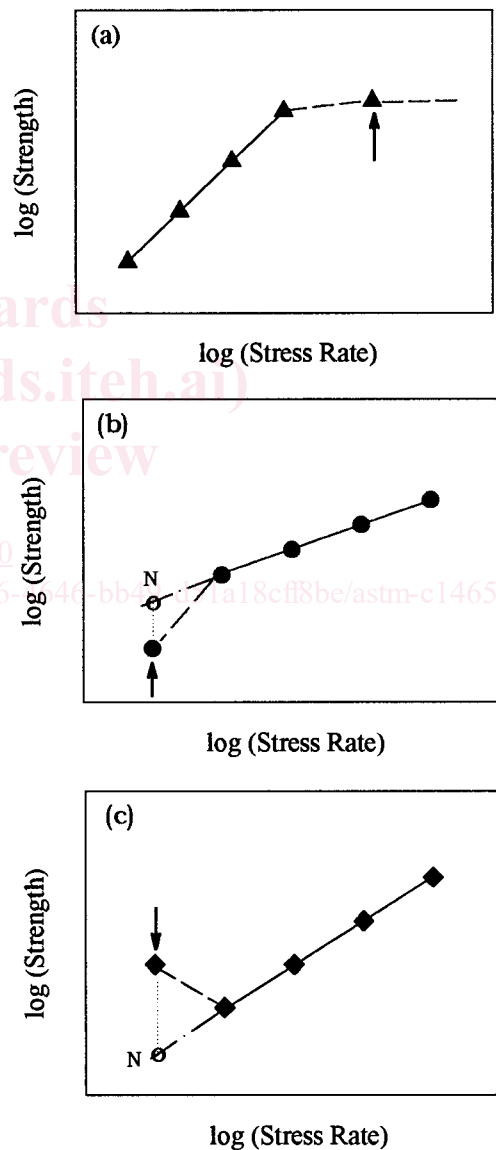

NOTE 1—The arrows indicate unacceptable data points. The data point marked with 'N', in which a significant nonlinearity occurs, indicates a strength value estimated by extrapolation of the linear regression line represented by the rest of the strength data.

FIG. 1 Schematic Diagrams Showing Unacceptable Data Points in Constant Stress-Rate Testing at Elevated Temperatures

5.4 A considerable strength degradation may be observed at lower stress rates and higher temperatures for some materials. In these cases, excessive creep damage in the form of creep cavities, micro- or macro-cracks, or both, develop in the tensile surface (10-13). This results in a nonlinearity in the relationship between log (*flexural strength*) and log (*applied stress rate*), see Fig. 1b. It has been reported that the strength degradation with respect to the expected normal strength (at Point N in Fig. 1b) ranged from 15 to 50 % (10-12). If these data points are used in the analysis, then an underestimate of the SCG parameters will be obtained. Hence, the strength data exhibiting such a significant strength degradation occurring at lower stress rates shall be excluded as data points in obtaining the SCG parameters of the material.

5.5 Contrary to the case of significant strength degradation, an appreciable strength increase may occur for some ceramics at lower stress rates (see Fig. 1c), due to crack healing or crack tip blunting which dominates slow crack growth (10, 14). It has been reported that the strength increase with respect to the expected normal strength (at point N in Fig. 1c) ranged from 15 to 60 % (10, 14). Since the phenomenon results in a deviation from the linear relationship between log (*flexural strength*) and log (*applied stress rate*), an overestimate of SCG parameters may be obtained if such strength data are included in the analysis. Therefore, any data exhibiting a significant or obvious increase in strength at lower stress rates shall be excluded as data points in estimating the SCG parameters of the material.

NOTE 6—It has been shown that some preloading (up to 80 % of fracture load) prior to testing may be used to minimize or eliminate the strength-increase phenomenon by minimizing or eliminating a chance for crack healing (or blunting) through shortening test time, as verified on some advanced ceramics such as alumina and silicon nitride (10, 15). In general, preloading may be effective to reduce overall creep deformation of test specimens due to reduced test time. Refer to 8.10 for more information regarding preloading and its application.

5.6 Surface preparation of test specimens can introduce fabrication flaws that may have pronounced effects on flexural strength. Machining damage imposed during specimen preparation can be either a random interfering factor, or an inherent part of the strength characteristics to be measured. Surface preparation can also lead to residual stress. Universal or standardized test methods of surface preparation do not exist. It should be understood that the final machining steps may or may not negate machining damage introduced during the early coarse or intermediate machining steps. In some cases, specimens need to be tested in the as-processed condition to simulate a specific service condition. Therefore, specimen fabrication history may play an important role in strength behavior, which consequently may affect the values of the SCG parameters to be determined.

6. Apparatus

6.1 *Test Machine*—Test machines used for this test method shall conform to the requirements of Practices E 4. Test specimens may be loaded in any suitable test machine provided that uniform test rates, either using load-control or displacement-control mode, can be maintained. The loads used in determining flexural strength shall be accurate within $\pm 1.0\%$ at any load within the selected test rate and load range

of the test machine as defined in Practices E 4. The test machine shall have a minimum capability of applying at least four test rates with at least three orders of magnitude, ranging from 10^{-1} to 10^{-2} N/s for load-control mode, and from 10^{-7} to 10^{-4} m/s for displacement-control mode.

6.2 *Test Fixtures*—The configurations and mechanical properties of test fixtures shall be in accordance with Test Method C 1211. The materials from which the test fixtures, including bearing cylinders, are fabricated shall be effectively inert to the test environment so that they do not significantly react with or contaminate either the test specimen or the test environment. In addition, the test fixtures must remain elastic under test conditions (load and temperature).

NOTE 7—Various grades of silicon carbide (such as hot-pressed or sintered) and high-purity aluminas are candidate materials for test fixtures as well as load train. The load-train material should also be effectively inert to the test environment and remain elastic under test conditions. For more specific information regarding use of appropriate materials for fixtures and load train with respect to test temperatures, refer to Section 6 of Test Method C 1211.

6.2.1 *Four-Point Flexure*—The four-point $\frac{1}{4}$ -point fixture configuration (see Fig. 2) as described in Test Method C 1211 shall be used in this test method. The nominal outer (support) span (L) for each test fixture is $L = 20$ mm, 40 mm, and 80 mm, respectively, for A, B, and C test fixtures. The use of three-point flexure is excluded from this test method.

6.2.2 *Bearing Cylinders*—The requirements of dimensions and mechanical properties of bearing cylinders as described in Test Method C 1211 shall be used in this test method. The bearing cylinders shall be free to rotate in order to relieve frictional constraints, as described in Test Method C 1211.

6.2.3 *Semiarticulating Four-Point Fixture*—The semiarticulating four-point fixture as described in Test Method C 1211 may be used in this test method. This fixture shall be used when the parallelism requirements of test specimens are met in accordance with Test Method C 1211.

6.2.4 *Fully Articulating Four-Point Fixture*—The fully articulating four-point fixture as described in Test Method

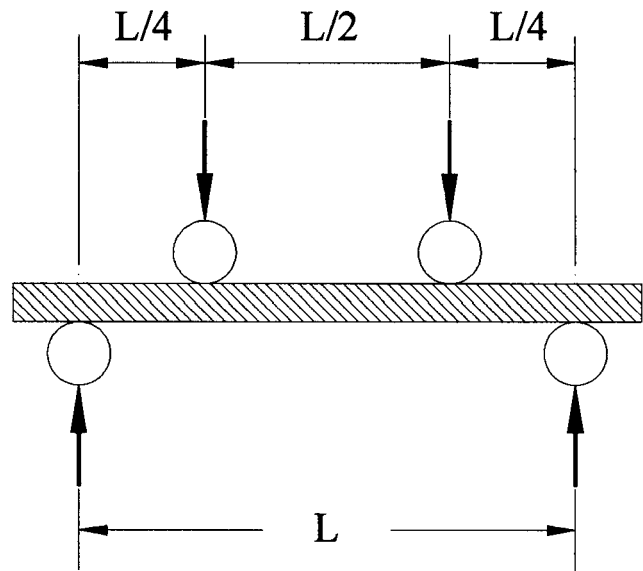

FIG. 2 Four-Point- $\frac{1}{4}$ Point Flexural Test Fixture Configuration

C 1211 may be used in this test method. Specimens that do not meet the parallelism requirements in Test Method C 1211, due to the nature of fabrication process (as-fired, heat-treated, or oxidized), shall be tested in this fully articulating fixture.

6.3 *System Compliance*—The test fixture and load train shall be sufficiently stiff so that at least 80 % of the crosshead or actuator movement of the test machine is imposed onto the test specimen up to the point of fracture. The test fixture and load train shall not undergo creep or nonlinear deformation under either load or displacement control.

NOTE 8—Compliance of the test fixture and load train at the test temperature can be estimated by inserting a rigid block of a ceramic material onto the test fixture with the loading bearing cylinders in place, and loading it to the maximum anticipated fracture load while recording a load-deflection curve. The compliance corresponds to the inverse of the slope of the load-deflection curve. It is recommended that the block be at least five times thicker than the test specimen depth and one to two times wider than the test specimen width. Any other block whose rigidity (equal to the inverse of compliance) is greater than at least 120 times that of the test specimen can be used provided that it can fit the test fixture. A typical test machine equipped with common load train and test fixtures shows that more than 90 % of the total compliance stems from the test specimen itself, so that more than 90 % of crosshead or actuator movement of test machine can be imposed on the test specimen.

6.4 *Heating Apparatus*—The heating systems such as furnace, temperature measuring device and thermocouple shall conform to the requirements as described in Test Method C 1211.

6.4.1 *Furnace and Temperature Readout Device*—The furnace shall be capable of maintaining the test specimen temperature within $\pm 2^{\circ}\text{C}$ during each testing period. The temperature readout device shall have a resolution of 1°C or lower. The furnace system shall be such that thermal gradients are minimal in the test specimen so that no more than a 5°C differential exists from end-to-end in the test specimen.

6.4.2 *Thermocouples:*

6.4.2.1 The specimen temperature shall be monitored by a thermocouple with its tip situated no more than 1 mm from the midpoint of the test specimen. Either a fully sheathed or exposed bead junction may be used. If a sheathed tip is used, it must be verified that there is negligible error associated with the covering.

NOTE 9—Exposed thermocouple beads have greater sensitivity, but they may be exposed to vapors that can react with the thermocouple materials. (For example, silica vapors will react with platinum.) Beware of the use of heavy-gage thermocouple wire, thermal gradients along the thermocouple length, or excessively heavy-walled insulators, all of which can lead to erroneous temperature readings.

NOTE 10—The thermocouple tip may contact the test specimen, but only if there is certainty that thermocouple tip or sheathing material will not interact chemically with the test specimen. Thermocouples may be prone to breakage if they are in contact with the test specimen.

6.4.2.2 A separate thermocouple may be used to control the furnace if necessary, but the test specimen temperature shall be the reported temperature of the test.

NOTE 11—Tests are sometimes conducted in furnaces that have thermal gradients. The small size of test specimens will alleviate thermal gradient problems, but it is essential to monitor the temperature at the test specimen.

6.4.2.3 The thermocouple(s) shall be calibrated in accordance with Test Method E 220 and Specification and Tables E 230. The thermocouples shall be periodically checked since calibration may drift with usage or contamination.

6.4.2.4 The measurement of temperature shall be accurate to within $\pm 5^{\circ}\text{C}$. The accuracy shall include the error inherent to the thermocouple as well as any errors in the measuring instruments.

NOTE 12—Resolution should not be confused with accuracy. Beware of recording instruments that read out to 1°C (resolution) but have an accuracy of only $\pm 10^{\circ}\text{C}$ or $\pm 1/2\%$ of full-scale (for example, $1/2\%$ of 1200°C is 6°C).

NOTE 13—Temperature measuring instruments typically approximate the temperature-electromotive force (EMF, in millivolt) tables, and may have an error of a few degrees.

6.4.2.5 The appropriate thermocouple extension wire should be used to connect a thermocouple to the furnace controller and temperature readout device, which shall have either a cold junction or a room-temperature compensation circuit. Special care should be directed toward connecting the extension wire with the correct polarity.

6.5 *Environmental Facility*—The furnace may have an air, inert, vacuum, or any other gaseous environment, as required. If testing is conducted in any gaseous environment other than ambient air, an appropriate environmental chamber shall be constructed to facilitate handling and monitoring of the test environment so that constant test conditions can be maintained. The chamber shall be effectively corrosion-resistant to the test environment so that it does not react with or change the environment. If it is necessary to direct load through bellows, fittings, or seal, it shall be verified that load losses or errors do not exceed 1 % of the prospective failure loads.

6.6 *Deflection Measurement*—When determined, measure deflection of the test specimen close to the midpoint or inner load point(s) (tension side). The method to measure the deflection of the midpoint relative to the two inner load points (for example, three-probe extensometer) can also be utilized, if determined. The deflection-measuring equipment shall be capable of resolving 1×10^{-3} mm. Deflection measurement of test specimens is particularly important at the test conditions of lower test rates or higher test temperatures, or both, and is highly recommended to ensure that creep strain of test specimens is within the allowable limit (see 8.11.2).

NOTE 14—Alternatively, crosshead or actuator displacement may be used to infer deflection of the test specimen. However, care should be taken in interpreting the result since crosshead or actuator displacement generally may not be as sensitive as measurements taken on the specimen itself.

NOTE 15—When a contact-type deflection-measuring equipment such as LVDT is employed, it is important not to damage the contact area of specimens due to prolonged contact with the deflection-measuring probe, particularly at lower test rates and higher test temperatures. Any spurious damage may act as a failure-originating source so that the contacting force should be kept minimal, in the range from 0.5 to 2 N. A general guideline is that the maximum contacting force is dependent on specimen size such that 0.5 N for Size A, 1 N for Size B, and 2 N for Size C specimen. The probe with its tip rounded may be fabricated with the same material as test specimens or with sintered silicon carbide.

6.7 *Data Acquisition*—Accurate determination of both fracture load and test time is important since they affect not only

fracture strength but applied stress rate. At the minimum, an autographic record of applied load versus time should be determined during testing. Either analog chart recorders or digital data acquisition systems can be used for this purpose. An analog chart recorder should be used in conjunction with the digital data acquisition system to provide an immediate record of the test as a supplement to the digital record. Recording devices shall be accurate to 1.0 % of the recording range and should have a minimum data acquisition rate of 1 kHz with a response of 5 kHz or greater deemed more than sufficient. The appropriate data acquisition rate depends on the test rate: The greater the test rate, the greater the acquisition rate; and vice versa.

7. Test Specimen

7.1 *Specimen Size*—The types and dimensions of rectangular beam specimens as described in Test Method C 1211 shall be used in this test method. The nominal dimensions of each type of test specimens are 2.0 by 25 mm (minimum), respectively, in width (*b*), depth (*d*), and length for Size A test specimens; 4.0 by 3.0 by 45 mm (minimum) for Size B test specimens; and 8.0 by 6.0 by 90 mm (minimum) for Size C test specimens.

7.2 *Specimen Preparation*—Specimen fabrication and preparation methods as described in Test Method C 1211 shall be used in this test method.

7.3 *Specimen Dimensions*—If there is a concern about a dimensional change in test specimens by possible reaction/reaction products due to a prolonged test duration particularly at very low test rates, measure test specimen dimensions prior to testing. Determine the thickness and width of each test specimen to within 0.002 mm either optically or mechanically using a flat, anvil-type micrometer. Exercise extreme caution to prevent damage to the critical area of the test specimen. Otherwise, measure the test specimen dimensions after testing (see 8.12.2).

7.4 *Handling and Cleaning*—Exercise care in handling and storing specimens in order to avoid introducing random and severe flaws, which might occur if the specimens were allowed to impact or scratch each other. If desired or necessary, clean test specimens with an appropriate cleaning medium such as methanol, high-purity (>99 %) isopropyl alcohol, or any other cleaning agent, since surface contamination of test specimens by lubricant, residues, rust, or dirt might affect slow crack growth for certain test environments. Also, residue from the cleaning medium, if any, shall not have any undesirable effect on slow crack growth (strength) of test specimens.

7.5 *Number of Test Specimens*—The required number of test specimens depends on the statistical reproducibility of SCG parameters (*n* and *D*) to be determined. The statistical reproducibility is a function of strength scatter (Weibull modulus), number of test rates, range of test rates, and SCG parameter (*n*). Because of these various variables, there is no single guideline as to the determination of the appropriate number of test specimens. A minimum of 10 specimens per test rate is recommended in this test method. The total number of test specimens shall be at least 40, with at least four different test rates (see 8.2.2). The number of test specimens (and test rates) recommended in this test method has been established with the

intent of determining reasonable confidence limits on both strength distribution and SCG parameters.

NOTE 16—Refer to Ref (2) when a specific purpose is sought for the statistical reproducibility of SCG parameters.

7.6 *Valid Tests*—A valid individual test is one which meets all the following requirements: (1) all the test requirements of this test method and (2) fracture occurring in the uniformly stressed section (that is, in the inner span) (see 8.12.3).

7.7 *Randomization of Test Specimens*—Since a somewhat large number of test specimens (a minimum of 40) with at least four different test rates is used in this test method, it is highly recommended that all the test specimens provided be randomized prior to testing in order to reduce any systematic error associated with material fabrication or specimen preparation, or both. Randomize the test specimens (using, for example, a random number generator) in groups equal to the number of test rates to be employed, if desired.

8. Procedure

8.1 *Test Fixtures*—Choose the appropriate fixture in the specific test configurations, as described in 6.2. Use the four-point A fixture for the Size A specimens. Similarly, use the four-point B fixture for Size B specimens, and the four-point C fixture for Size C specimens. A fully articulating fixture is required if the specimen parallelism requirements cannot be met.

8.2 Test Rates:

8.2.1 The choice of range and number of test rates not only affects the statistical reproducibility of SCG parameters but depends on the capability of a test machine. Since various types of test machines are currently available, no simple guideline regarding the range of test rates can be made. However, when the lower limits of the test rates of most commercial test machines are considered (often attributed to insufficient resolution of crosshead or actuator movement control), it is generally recommended that the lowest test rates be $\geq 10^{-2}$ N/s and 10^{-8} m/s, respectively, for load- and displacement-controlled modes. Choice of the upper limits of the test rates of test machines is dependent on several factors associated with the dynamic response of the crosshead or actuator, the load cell, and the data acquisition system (including the chart recorder, if used). Since these factors vary widely from one test machine to another, depending on their capability, no specific upper limit can be established. However, based on the factors common to many test machines and in order to avoid data generation in a plateau region (see 5.2), it is generally recommended that the upper test rates be $\leq 10^3$ N/s and 10^{-3} m/s, respectively, for load- and displacement-control modes.

8.2.2 For a test machine equipped with load-control mode, choose at least four load rates (evenly spaced in a logarithmic scale) covering three orders of magnitude (for example, 10^{-1} , 10^0 , 10^1 , and 10^2 N/s). Similarly, for a test machine equipped with displacement-control mode, choose at least four displacement rates (evenly spaced in a logarithmic scale) covering three orders of magnitude (for example, 10^{-7} , 10^{-6} , 10^{-5} , and 10^{-4} m/s). The use of five or more test rates (evenly spaced in a logarithmic scale) covering four or more orders of magnitude