



Standard Test Method for Distortion Temperature in Three-Point Bending by Thermomechanical Analysis¹

This standard is issued under the fixed designation E 2092; the number immediately following the designation indicates the year of original adoption or, in the case of revision, the year of last revision. A number in parentheses indicates the year of last reapproval. A superscript epsilon (ϵ) indicates an editorial change since the last revision or reapproval.

1. Scope

1.1 This test method describes the determination of the temperature at which the specific modulus of a test specimen is realized by deflection in three-point bending. This temperature is identified as the distortion temperature measured. The distortion temperature is that temperature at which a test specimen of defined geometry deforms to a level of strain under applied stress of 0.455 and 1.82 MPa (66 and 264 psi) equivalent to those used in Test Method D 648. The test may be performed over the range of temperature from ambient to 300°C.

NOTE 1—Results may or may not agree with those obtained by Test Method D 648.

1.2 Electronic instrumentation or automated data analysis and reduction systems or treatments equivalent to this test method may be used.

NOTE 2—Since all electronic data treatments are not equivalent, the user shall verify equivalency to this test method.

1.3 SI values are to be regarded as the standard. Inch-pound units in parentheses are for information only.

1.4 *This standard does not purport to address all of the safety problems, if any, associated with its use. It is the responsibility of the user of this standard to establish appropriate safety and health practices and to determine the applicability of regulatory limitations prior to use.*

1.5 There is no ISO standard equivalent to this test method.

2. Referenced Documents

2.1 ASTM Standards:

D 648 Test Method for Deflection Temperature of Plastics Under Flexural Load²

E 473 Terminology Relating to Thermal Analysis³

E 1142 Terminology Relating to Thermophysical Properties³

E 1363 Test Method for Temperature Calibration of Thermomechanical Analyzers³

¹ This test method is under the jurisdiction of Committee E-37 on Thermal Measurements and is the direct responsibility of Subcommittee E37.01 on Test Methods and Recommended Practices.

Current edition approved May 10, 2000. Published July 2000.

² Annual Book of ASTM Standards, Vol 08.01.

³ Annual Book of ASTM Standards, Vol 14.02.

3. Terminology

3.1 *Definitions*—Specific technical terms used in this standard are defined in Terminologies E 473 and E 1142.

3.1.1 *distortion temperature* [$^{\circ}\text{C}$], n —the temperature at which an arbitrary strain level is obtained in three-point bending under an arbitrary load.

3.1.2 *strain*, r [mm/m], n —the dimension change in normalizing dimension due to an applied force.

3.1.3 *stress*, S [$\text{Pa} = \text{N}/\text{m}^2$], n —force per unit area.

4. Summary of Test Method

4.1 A test specimen of known dimensions is tested in three-point bending mode. A known stress is applied to the center of a test specimen supported near its ends, as it is heated at a constant rate from ambient temperature to the upper temperature limit for the material. The deflection of the test specimen is recorded as a function of temperature. The temperature at which a predetermined level of strain is observed in the test specimen is analyzed as the distortion temperature.

5. Significance and Use

5.1 Data obtained by this test method shall not be used to predict the behavior of materials at elevated temperatures except in applications in which the conditions of time, temperature, method of loading, and stress are similar to those specified in the test.

5.2 This standard is particularly suited for quality control and development work. The data are not intended for use in design or predicting endurance at elevated temperatures.

6. Apparatus

6.1 A thermomechanical analyzer consisting of:

6.1.1 *Rigid Specimen Holder*, of inert, low expansivity material ($< 20 \mu\text{m}/(\text{m} \cdot ^{\circ}\text{C})$) to center the specimen in the furnace and to fix the specimen to mechanical ground.

6.1.2 *Flexure Fixture*, of inert, low expansivity material ($< 20 \mu\text{m}/(\text{m} \cdot ^{\circ}\text{C})$), to support the test specimen in a three-point bending mode (see Fig. 1).

6.1.3 *Rigid Knife Edge Compression Probe*, of inert, low expansivity material ($< 20 \mu\text{m}/(\text{m} \cdot ^{\circ}\text{C})$) that contacts the specimen with an applied compression force (see Fig. 1).

6.1.4 *Deflection Sensing Element*, having a linear output over a minimum range of 5 mm to measure the displacement of

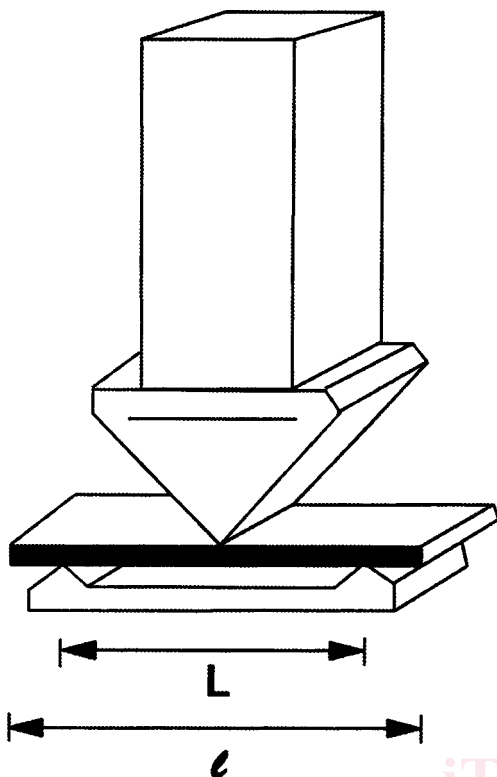

FIG. 1 Flexure Support Geometry

the rigid compression probe (see 6.1.3) to within $\pm 0.1 \mu\text{m}$.

6.1.5 *Programmable Weight or Force Transducer*, to generate a constant force ($\pm 2.5\%$) between at least 0.01 to 1.0 N, that is applied to the specimen through the rigid compression probe (see 6.1.3).

6.1.6 *Temperature Sensor*, that can be positioned reproducibly in close proximity to the specimen to measure its temperature of the range between 25 and 300°C to $\pm 0.1^\circ\text{C}$.

6.1.7 *Temperature Programmer and Furnace*, capable of temperature programming the test specimen from ambient to 300°C at a linear rate of at least $2 \pm 0.1^\circ\text{C}/\text{min}$.

6.1.8 *Means of Providing a Specimen Environment*, of inert gas at a purge rate of 50 mL/min $\pm 5\%$.

NOTE 3—Typically, inert purge gases that inhibit specimen oxidation are 99.9+ % pure nitrogen, helium or argon. Subambient operation requires dry purge gas. Dry gases are recommended for all experiments unless the effect of moisture is part of the study.

6.1.9 *Recording Device*, either digital or analog, to record and display the experimental parameters of deflection on the Y axis (ordinate) to a sensitivity of $\pm 0.1 \mu\text{m}$ and of temperature on the X axis (abscissa) to a sensitivity of $\pm 0.1^\circ\text{C}$.

6.1.10 While not required, it is convenient to have a data analysis device, that will perform and display the calculations of this standard.

6.2 Micrometer, calipers, film gage or other length-measuring device capable of measuring lengths of 0.01 to 20 mm with a precision of $\pm 0.001 \text{ mm}$.

7. Hazards

7.1 Toxic or corrosive effluents, or both, may be released when heating some materials and could be harmful to personnel and to apparatus.

7.2 Because the specimen size is small, care must be taken to ensure that each specimen is homogeneous and representative of the sample as a whole.

7.3 The test specimen shall be isotropic. See 8.3.

8. Sampling

8.1 The specimens may be cut from sheets, plates, or molded shapes, or may be molded to the desired finished dimensions.

8.2 The specimens used in this test method are ordinarily in the form of rectangular beams with aspect ratios of 1: 3: 10 for thickness (d), width (b) and length (l), depending upon the modulus of the sample and length of the support span (L).

NOTE 4—Other specimen and support dimensions may be used but care must be taken that the support length to specimen thickness ratio (L/d) be greater than 10.

NOTE 5—The specimen shall be long enough to allow overhanging on each end of at least 10 % of the support span, that is, $l \geq 1.2 L$.

NOTE 6—The overhang shall be sufficient to prevent the specimen from slipping from the supports.

8.3 This test method assumes that the material is isotropic. Should the specimen be anisotropic, such as in reinforced composites, the direction of the reinforcing agent shall be reported relative to the specimen dimensions.

8.4 Since duplicate determinations are required, at least 2 specimens shall be prepared from each sample.

9. Calibration

9.1 Calibrate the temperature display of the apparatus according to Test Method E 1363 using a heating rate of $2 \pm 0.1^\circ\text{C}/\text{min}$.

9.2 Calibrate the deflection display of the apparatus according to the instrument manufacturer's instructions.

9.3 Calibrate the mechanism for applying force to the test specimen according to the instrument manufacturer's instructions.

10. Procedure

10.1 Measure the test length (L) of the test specimen as the distance between the two support points of the flexure support geometry to three significant figures (see Fig. 1).

10.2 Measure the width (b) and thickness (d) of the test specimen to three significant figures (see Fig. 2).

10.3 Select the stress (S) to be applied to the test specimen. This value is typically 0.455 or 1.82 MPa (66 or 264 psi) to correspond with the values used in Test Method D 648.

NOTE 7—Other values may be used but shall be reported.

10.4 Select the strain (r) to be used to identify the heat distortion temperature.

NOTE 8—This value is typically 2.0 mm/m (0.20 %) to correspond with the values used in Test Method D 648.

10.5 Using Eq 1, calculate the force (F) to be applied to the test specimen to three significant figures.

10.6 Using Eq 3, calculate the deflection (D) to be used as the experimental endpoint to three significant figures.

10.7 Center the specimen on the supports, with the long axis of the specimen perpendicular to the loading nose and supports (see Fig. 1).