

INTERNATIONAL STANDARD

**ISO
7682**

First edition
1991-05-15

Acrylonitrile/butadiene/styrene (ABS) pipes and fittings for soil and waste discharge (low and high temperature) systems inside buildings — Specifications

iTeh STANDARD PREVIEW
(standards.iteh.ai)

Tubes et raccords en acrylonitrile/butadiène/styrène (ABS) pour les systèmes d'évacuation d'eaux usées et d'eaux-vannes (à basse et à haute température) à l'intérieur des bâtiments — Spécifications

<https://standards.iteh.ai/catalog/standards/sist/43eac759-5d1e-4955-9c24-2081a03a00e8/iso-7682-1991>



Reference number
ISO 7682:1991(E)

Foreword

ISO (the International Organization for Standardization) is a worldwide federation of national standards bodies (ISO member bodies). The work of preparing International Standards is normally carried out through ISO technical committees. Each member body interested in a subject for which a technical committee has been established has the right to be represented on that committee. International organizations, governmental and non-governmental, in liaison with ISO, also take part in the work. ISO collaborates closely with the International Electrotechnical Commission (IEC) on all matters of electrotechnical standardization.

Draft International Standards adopted by the technical committees are circulated to the member bodies for voting. Publication as an International Standard requires approval by at least 75 % of the member bodies casting a vote.

International Standard ISO 7682 was prepared by Technical Committee ISO/TC 138, *Plastics pipes, fittings and valves for the transport of fluids*.

Annexes A, B, C, D, E, F, G, H, J and K form an integral part of this International Standard. Annex I is for information only.

THE STANDARD PREVIEW
(standards.itcl.ai)
<https://standards.iso.org/standards/catalog/standards/sist/43eac759-5d1e-4955-9c24-2081a03a00e8/iso-7682-1991>

© ISO 1991

All rights reserved. No part of this publication may be reproduced or utilized in any form or by any means, electronic or mechanical, including photocopying and microfilm, without permission in writing from the publisher.

International Organization for Standardization
Case Postale 56 • CH-1211 Genève 20 • Switzerland

Printed in Switzerland

Acrylonitrile/butadiene/styrene (ABS) pipes and fittings for soil and waste discharge (low and high temperature) systems inside buildings — Specifications

1 Scope

This International Standard lays down the specifications for acrylonitrile/butadiene/styrene (ABS) pipes and fittings, with nominal outside diameters of 32 mm to 160 mm, intended for domestic installations inside buildings for

- a) soil and waste discharge pipe lines (including the ventilation of these pipes), and
- b) internal rainwater pipes

for the transportation of domestic waste waters¹⁾ (low and high temperature).

Two systems, type A and type B, are specified²⁾. Both systems are suitable for this field of application. However, type B is recommended for applications where higher impact performance is required. This higher impact performance is normally associated with lower temperatures during handling and installation.

This International Standard may also be applied to pipes, fittings and joints for discharges of industrial origin, provided chemical and temperature resistance is taken into account.

2 Normative references

The following standards contain provisions which, through reference in this text, constitute provisions of this International Standard. At the time of publication, the editions indicated were valid. All standards are subject to revision, and parties to agreements based on this International Standard are encouraged to investigate the possibility of applying the most recent editions of the standards in-

dicated below. Members of IEC and ISO maintain registers of currently valid International Standards.

ISO 179:1982, *Plastics — Determination of Charpy impact strength of rigid materials.*

ISO 265-1:1988, *Pipes and fittings of plastics materials — Fittings for domestic and industrial waste pipes — Basic dimensions: Metric series — Part 1: Unplasticized poly(vinyl chloride) (PVC-U).*

ISO 580:1990, *Injection-moulded unplasticized poly(vinyl chloride) (PVC-U) fittings — Oven test — Test method and basic specifications.*

ISO 1043-1:1987, *Plastics — Symbols — Part 1: Basic polymers and their special characteristics.*

ISO 3127:1980, *Unplasticized polyvinyl chloride (PVC) pipes for the transport of fluids — Determination and specification of resistance to external blows.*

ISO 3606:1976, *Unplasticized polyvinyl chloride (PVC) pipes — Tolerances on outside diameters and wall thicknesses.*

ISO/TR 7024:1985, *Above-ground drainage — Recommended practice and techniques for the installation of unplasticized polyvinyl chloride (PVC-U) sanitary pipework for above-ground systems inside buildings.*

ISO 7245:1984, *Pipes and fittings of acrylonitrile/butadiene/styrene (ABS) — General specification for moulding and extrusion materials.*

ISO 7246:1984, *Pipes and fittings of acrylonitrile/styrene/acrylester (ASA) — General specification for moulding and extrusion materials.*

1) For the definition of the term "domestic waste waters" refer to annex A or, alternatively, to national regulations.

2) Individual countries may select either type for their national standards.

ISO 8283-4:—³⁾, *Plastics pipes and fittings — Dimensions of sockets and spigots for discharge systems inside buildings — Part 4: Acrylonitrile/butadiene/styrene (ABS)*.

3 Material

3.1 The material shall consist of acrylonitrile/butadiene/styrene (ABS) copolymer or terpolymer in accordance with ISO 7245, to which may be added acrylonitrile/styrene/acrylester (ASA) in accordance with ISO 7246 together with only those additives needed to facilitate the manufacture of sound, durable pipes and fittings with good surface finish and opacity.

When required by national regulations, further appropriate additives may be used to retard the flammable properties of the material.

3.2 The use of the manufacturer's own clean rework material from pipes and fittings made to this International Standard is permissible. No other rework material shall be used.

3.3 Pipes and fittings shall be sufficiently stabilized against ultraviolet (UV) light.

NOTE 1 Resistance to UV light is under study within ISO/TC 138.

4 Geometrical characteristics

4.1 Pipe dimensions

4.1.1 Nominal outside diameter

The nominal outside diameter D shall be in accordance with table 1.

Table 1 — Nominal outside diameter

Dimensions in millimetres

32	40	50	63	75	90	110	125	160
NOTE — These values have been taken from ISO 161-1:1978, <i>Thermoplastics pipes for the transport of fluids — Nominal outside diameters and nominal pressures — Part 1: Metric series</i>								

Tolerances on outside diameters shall be in accordance with ISO 3606.

3) To be published.

4.1.2 Wall thickness

The wall thickness shall be in accordance with table 2.

Tolerances on wall thicknesses shall be in accordance with ISO 3606.

Table 2 — Wall thickness

Dimensions in millimetres

Nominal outside diameter D	Minimum wall thickness e_{min}	
	Type A	Type B
32	1,8	2,2
40	1,8	2,2
50	1,8	2,2
63	1,8	2,2
75	1,8	2,5
90	1,8	2,8
110	2,2	3,2
125	2,5	3,7
160	3,2	4,7

4.1.3 Length of pipe

The nominal length of a pipe shall be measured as shown in figure 1. For pipes with sockets, the nominal length is considered to be the distance between the ends minus the socket depth. For practical reasons, this length is measured to the outside of the socket.

The nominal pipe length l shall be as agreed between purchaser, user and manufacturer.

4.2 Dimensions of fittings

4.2.1 Basic dimensions

Basic dimensions of fittings shall be given by the manufacturer, and the dimensions shall be defined as in ISO 265-1.

4.2.2 Wall thickness

The wall thickness shall be at least equal to the minimum wall thickness of the pipe of the same size and type unless otherwise specified in 4.3.2.

4.3 Socket and spigot dimensions of pipes and fittings

4.3.1 Basic dimensions

Basic dimensions of sockets and spigots of pipes and fittings shall be as given in ISO 8283-4.

4.3.2 Wall thickness of sockets on pipes and fittings

The minimum wall thickness of sockets shall meet the requirements of table 3 (see figure 2 for an example).

When a seal ring is firmly retained by means of a seal ring retaining component (see figure 3 for an example), the wall thickness of the socket in this area and that of the seal ring retaining component may be added together to achieve the required e_3 dimension provided that they are not separated by the seal ring.

The minimum values of e_3 given in table 3 apply only to those parts of the ring seal zone where the liquid in the pipe comes into contact with the fitting. For those parts of the fitting that do not come into contact with the liquid, i.e. beyond the designated ring seal point, thinner walls are permitted.

Retaining caps or rings may be made to other designs and from polymers other than ABS provided that they conform to the same functional dimensions and test requirements as applied to sockets with either loose or fixed seal rings.

In all cases, the components shall meet the functional test requirements specified in clause 7.

Table 3 — Minimum wall thickness of sockets on pipes and fittings

Dimensions in millimetres

Nominal outside diameter D	e_2 ¹⁾ min.		e_3 ²⁾ min.	
	Type A	Type B	Type A	Type B
32	1,7	2	1	1,3
40	1,7	2	1	1,3
50	1,7	2	1	1,3
63	1,7	2	1	1,3
75	1,7	2,3	1	1,4
90	1,7	2,6	1	1,6
110	2	2,9	1,3	1,8
125	2,3	3,4	1,4	2,1
160	2,9	4,3	1,8	2,6

1) Type A and B: $e_2 = 0,9e$
 2) Type A and B: $e_3 = 0,55e$

iTeh STANDARD PREVIEW
(standards.iteh.ai)

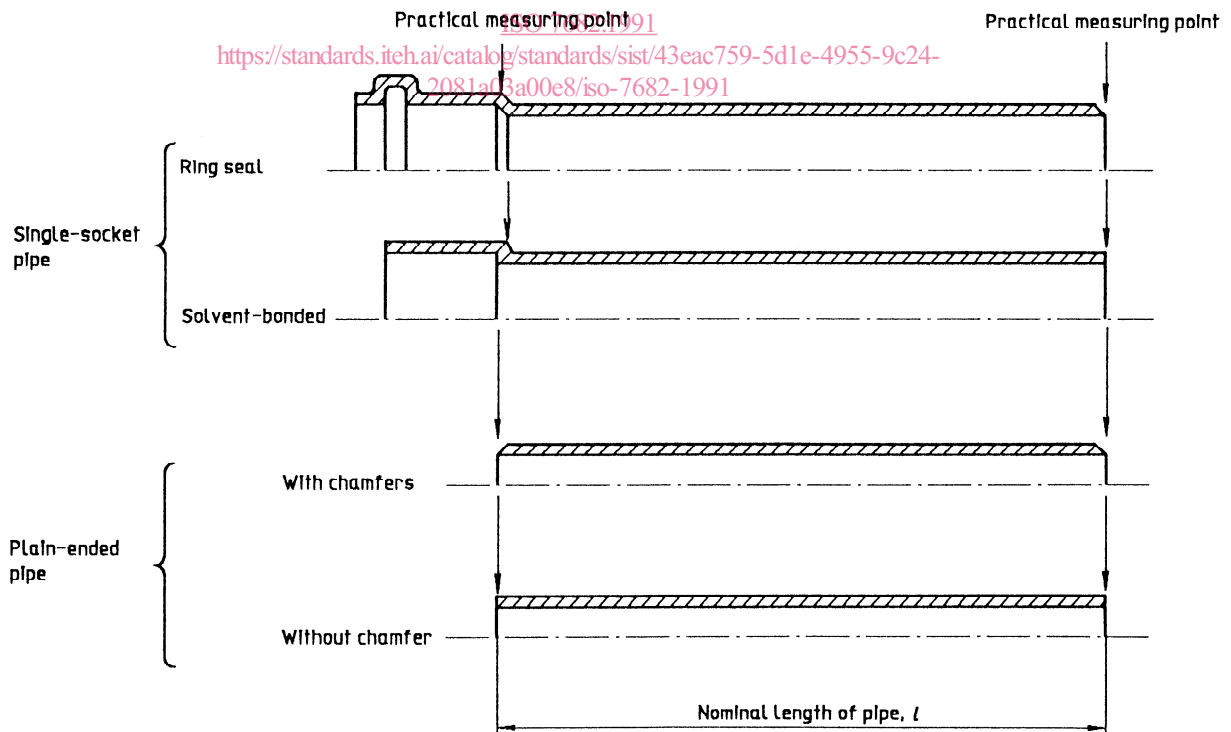

Figure 1 — Nominal pipe length and definitions

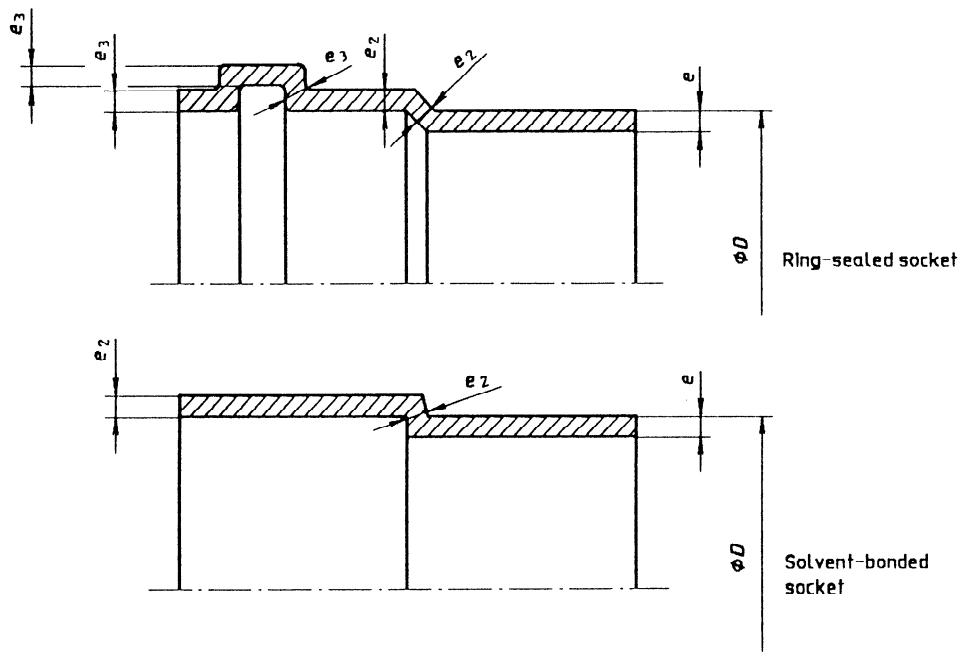

Figure 2 — Socket details

iTeh STANDARD PREVIEW
(standards.iteh.ai)

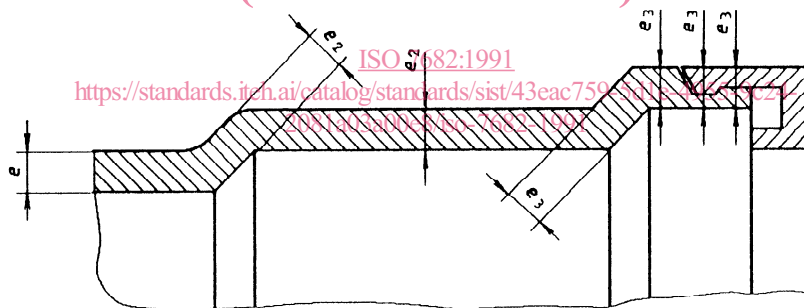

Figure 3 — Example of a seal retaining cap

5 Mechanical test requirements

5.1 Pipes

5.1.1 Impact strength

The true impact rate (TIR) shall be not higher than 5 % when tested in accordance with ISO 3127 and under the test conditions specified in annex B.

5.1.2 Resistance to high-temperature ageing

The true impact rate (TIR) shall not exceed 5 % when tested using the method specified in annex C.

5.2 Fittings

5.2.1 Impact strength

Five fittings of each diameter and type shall be conditioned for at least 30 min at a temperature of $0\text{ }^{\circ}\text{C} \pm 1\text{ }^{\circ}\text{C}$. Within 10 s after the conditioning treatment, each fitting shall be dropped freely in various positions on to a flat concrete floor from the heights specified below:

- for $D \leq 75\text{ mm}$, drop from $(2\text{ }^{+0,1}_0)\text{ m}$;
- for $D > 75\text{ mm}$, drop from $(1\text{ }^{+0,1}_0)\text{ m}$.

If none of the specimens is damaged in the test, the fittings shall be accepted. If one fitting is damaged,

the test shall be repeated with five further fittings. None of these last five fittings shall be damaged.

NOTE 2 In the context of this test, "damage" means any visible split or any complete breakage in the body of the fitting. Surface scratches, scuffing, or chipping of edges which may occur in the test does not constitute damage.

5.2.2 Resistance to high-temperature ageing

After exposure in accordance with annex C, the Charpy impact strength shall be determined according to annex D. If all values exceed 30 kJ/m², the requirements of this test are met. If some values are lower, then the fittings are only acceptable if the mean minus one standard deviation exceeds 30 kJ/m².

To obtain the correct size of test piece, samples shall be taken where possible from couplings of diameter greater than 50 mm.

6 Physical test requirements

6.1 Pipes

6.1.1 Vicat softening temperature

6.1.1.1 The dry Vicat softening temperature shall be not less than 90 °C.

6.1.1.2 The Vicat softening temperature after conditioning for 16 h in water at 90 °C shall be not less than 80 °C.

6.1.1.3 A test method to determine the Vicat softening temperature of ABS materials will form the subject of a future International Standard.

6.1.2 Water absorption

The water absorption shall be less than 3 % (*m/m*). A test method to determine the water absorption will form the subject of a future International Standard.

6.1.3 Longitudinal reversion

The longitudinal reversion shall not exceed 5 %. A test method to determine the longitudinal reversion of ABS materials will form the subject of a future International Standard.

6.1.4 Axial shrinkage

The axial shrinkage shall not exceed 1,5 % when determined in accordance with annex E.

6.2 Fittings

6.2.1 Vicat softening temperature

6.2.1.1 The dry Vicat softening temperature shall be not less than 90 °C.

6.2.1.2 The Vicat softening temperature after conditioning for 16 h in water at 90 °C shall be not less than 80 °C.

6.2.1.3 A test method to determine the Vicat softening temperature of ABS materials will form the subject of a future International Standard.

6.2.2 Water absorption

The water absorption shall be less than 3 % (*m/m*). A test method to determine the water absorption will form the subject of a future International Standard.

6.2.3 Oven test

Moulded fittings shall meet the requirements of ISO 580.

7 Functional test requirements (type tests)

7.1 Watertightness

ISO 7682:1991
<https://standards.iteh.ai/catalog/standards/sist/43eac759-5d1e-4955-9c24-2081a03a00e8/iso-7682-1991>
 Joints between pipes and fittings, pipes and pipes, and fittings and fittings shall not leak when tested in accordance with annex F.

7.2 Airtightness

Joints between pipes and fittings, pipes and pipes, and fittings and fittings shall remain airtight when tested in accordance with annex G.

7.3 Elevated-temperature cycling test

The test assembly used shall meet the requirements given in either annex H or annex J. Where national standards specify which of these two tests is to be used, they shall be complied with.

Annex K specifies the information to be provided and the symbols to be used in the test report.

8 Elastomeric sealing elements and adhesives

All elastomeric sealing elements and adhesives shall be as specified by the manufacturer of the fittings.

The sealing elements and adhesive shall not have a detrimental effect on the pipes or fittings, i.e. they

shall not cause the test assembly to fail the functional tests.

9 Delivery conditions

9.1 Appearance

The internal and external surfaces of pipes and fittings shall be smooth and free from grooving, blistering and any other surface defect. The materials shall not contain visible impurities or pores. Pipe ends shall be cleanly cut, and the ends of pipes and fittings shall be square with the axis of the pipe.

9.2 Colour

Colours shall be as specified in national standards or regulations, or as agreed between manufacturer and user.

10 Marking

Pipes, fittings and sealing rings shall be marked clearly and indelibly so that legibility is maintained for the life of the products under normal conditions of storage, weather and use.

The markings may be integral with the product or on a label. The markings shall not damage the product.

10.1 Pipes

Pipes shall be marked with at least the following information:

- manufacturer's name or trade mark;
- pipe material;
- nominal diameter of pipe;
- nominal wall thickness of pipe;
- manufacturing information, in plain text or in code, providing traceability of the production period to within the year and month and the production site if the manufacturer is producing at several national or international sites;
- the number of this International Standard.

Pipes with a nominal laying length up to and including z_2 metres shall be marked at least once. Pipes with a nominal laying length greater than z_2 shall be marked at intervals of z_3 metres at the most. The

values of z_2 and z_3 shall be as specified by the authorities in each country.

10.2 Fittings

Fittings shall be marked with at least the following information:

- manufacturer's name or trade mark;
- fitting material (may be given on packing only in the case of PVC, provided this information is not required on each article by national authorities);
- nominal diameter of fitting;
- classification (where applicable);
- values of angles, if any;
- manufacturing information, in plain text or in code, providing traceability of the production period to within the year and month and the production site if the manufacturer is producing at several national or international sites (may be given on packing only, provided this information is not required on each article by national authorities);
- the number of this International Standard (may be given on packing only, provided this information is not required on each article by national authorities).

10.3 Sealing rings

Sealing rings shall be marked with at least the following information:

- manufacturer's name or trade mark;
- nominal dimension of ring;
- manufacturing information, in plain text or in code, providing traceability of the production period to within the year and the production site if manufacturer is producing at several national or international sites.

No markings are required on sealing rings which are moulded to pipes or fittings or any other marked component.

10.4 Designation of the material (in accordance with ISO 1043-1)

ABS

Annex A (normative)

Definition of domestic waste waters

domestic waste waters: Waters discharged and diverted into the sewage system, in particular

- a) waters that have become altered in composition and have become fouled (or impure) by being used domestically (including waters from flushing systems containing human excrement and, if necessary or authorized, animal excrement, and

waters from normal households, offices, old people's homes, hotels, schools, etc.), and

- b) rainwater, if a separate discharge channel is not available.

Such waters never have a temperature exceeding 100 °C continuously for more than 2 min and have a pH value normally in the range pH 2 to pH 12.

Annex B (normative)

iTeh STANDARD PREVIEW

Determination of resistance to external blows

B.1 Test method and apparatus

ISO 7682:1991

<https://standards.iteh.ai/catalog/standards/sist/43eac759-5d1e-4955-9c24-2081a03a00e8/iso-7682-1991>

See ISO 3127.

Should any test specimen show excessive distortion after impacting, further testing on this specimen shall be discontinued; further specimens shall be taken to continue the testing, to ensure a cumulative total number of strikes.

B.2 Test conditions

The test temperature shall be 0 °C ± 1 °C.

The mass of the falling weight and the fall height shall be selected from table B.1.

Table B.1 — Mass and fall height

Nominal outside diameter <i>D</i> mm	Mass of falling weight g +10 0	Fall height mm +20 0
32	500	1 500
40	500	1 800
50	500	2 000
63	500	2 000
75	1 000	2 000
90	2 000	2 000
110	2 000	2 000
125	2 700	2 000
160	3 750	2 000

Annex C (normative)

Resistance to high-temperature ageing

C.1 Exposure conditions

Test specimens shall be exposed in a standing position (if necessary in layers) for a period of 500 h at $90\text{ °C} \pm 2\text{ °C}$ and a relative humidity of at least 80 %.

C.2 Test method and apparatus

See ISO 3127.

C.3 Test conditions

The test temperature shall be $0\text{ °C} \pm 1\text{ °C}$.

The mass of the falling weight and the fall height shall be selected from table C.1.

Table C.1 — Mass and fall height

Nominal outside diameter. <i>D</i> mm	Mass of falling weight g +10 0	Fall height mm +20 0
32	250	2 000
40	250	2 000
50	250	2 000
63	250	2 000
75	500	2 000
90	1 000	2 000
110	1 000	2 000
125	1 500	2 000
160	1 750	2 000

(standards.iteh.ai)

[ISO 7682:1991](https://standards.iteh.ai/catalog/standards/sist/43eac759-5d1e-4955-9c24-2081a03a00e8/iso-7682-1991)

<https://standards.iteh.ai/catalog/standards/sist/43eac759-5d1e-4955-9c24-2081a03a00e8/iso-7682-1991>

Annex D
(normative)

Charpy impact strength of fittings

D.1 Apparatus

See ISO 179, with the exception that the distance between the supports shall be 22 mm.

D.2 Test pieces

Ten test pieces shall be taken at random from one or more injection-moulded straight couplings, avoiding weld lines and injection areas, of the same type and batch, with the dimensions shown in figure D.1.

D.3 Conditioning

The test pieces shall be kept for at least 16 h at 23 °C ± 2 °C and a relative humidity of (50 ± 5) %.

D.4 Procedure

For every test piece, determine the width measured across the chord at the mid-length and the thickness with an accuracy of 0,05 mm.

For every test piece, determine the impact energy, A , and calculate the Charpy impact strength using the equation

$$a = \frac{A}{b \times e}$$

where

- a is the Charpy impact strength, in kilojoules per square metre;
- A is the impact energy, in kilojoules, absorbed by the test piece;
- b is the width of the test piece, in metres;
- e is the thickness of the test piece, in metres.

Average the ten values and calculate the standard deviation using the equation

$$s = \sqrt{\frac{\sum (a_i - a_m)^2}{n - 1}}$$

where

- s is the standard deviation, in kilojoules per square metre;
- a_i is the Charpy impact strength, in kilojoules per square metre, of the i th test piece;
- a_m is the mean Charpy impact strength, in kilojoules per square metre;
- n is the total number of test pieces.

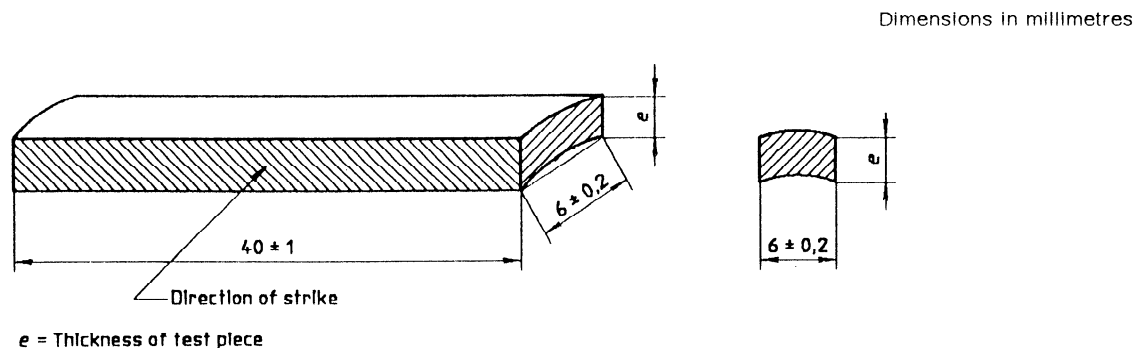

Figure D.1 — Test piece