



SLOVENSKI STANDARD
SIST EN 1970:2000
01-november-2000

Nastavljive postelje za invalidne osebe - Zahteve in preskusne metode

Adjustable beds for disabled persons - Requirements and test methods

Verstellbare Betten für behinderte Menschen - Anforderungen und Prüfverfahren

Lits réglables pour les personnes handicapées - Exigences et méthodes d'essai

ITEH STANDARD PREVIEW
 (standards.iteh.ai)

Ta slovenski standard je istoveten z: EN 1970:2000

SIST EN 1970:2000

<https://standards.iteh.ai/catalog/standards/sist/f06df021-b87a-4d2b-9fa9-dea9f7b34497/sist-en-1970-2000>

ICS:

11.180.99	Öl * á cæ å æ å å ç Á ç ^: á] i á [{ [\ á æ ç ç á ^	Other standards related to aids for disabled and handicapped people
97.140	Pohištvo	Furniture

SIST EN 1970:2000 en

iTeh STANDARD PREVIEW
(standards.iteh.ai)

SIST EN 1970:2000

<https://standards.iteh.ai/catalog/standards/sist/f06df021-b87a-4d2b-9fa9-dea9f7b34497/sist-en-1970-2000>

ICS 11.180; 97.140

English version

Adjustable beds for disabled persons - Requirements and test methods

Lits réglables pour les personnes handicapées - Exigences et méthodes d'essai

Verstellbare Betten für behinderte Menschen - Anforderungen und Prüfverfahren

This European Standard was approved by CEN on 11 May 2000.

CEN members are bound to comply with the CEN/CENELEC Internal Regulations which stipulate the conditions for giving this European Standard the status of a national standard without any alteration. Up-to-date lists and bibliographical references concerning such national standards may be obtained on application to the Central Secretariat or to any CEN member.

This European Standard exists in three official versions (English, French, German). A version in any other language made by translation under the responsibility of a CEN member into its own language and notified to the Central Secretariat has the same status as the official versions.

CEN members are the national standards bodies of Austria, Belgium, Czech Republic, Denmark, Finland, France, Germany, Greece, Iceland, Ireland, Italy, Luxembourg, Netherlands, Norway, Portugal, Spain, Sweden, Switzerland and United Kingdom.

iTeh STANDARD PREVIEW
(standards.iteh.ai)

SIST EN 1970:2000

<https://standards.iteh.ai/catalog/standards/sist/f06af021-b87a-4d2b-9fa9-dea9f7b34497/sist-en-1970-2000>



EUROPEAN COMMITTEE FOR STANDARDIZATION
COMITÉ EUROPÉEN DE NORMALISATION
EUROPÄISCHES KOMITEE FÜR NORMUNG

Central Secretariat: rue de Stassart, 36 B-1050 Brussels

Contents

Foreword	4
Introduction	5
1 Scope	6
2 Normative references	6
3 Terms and definitions	7
4 General safety requirements	13
4.1 Safe working load	14
4.2 Maximum mass of knock-down parts	15
5 Specific safety requirements and related test methods	15
5.1 General test conditions	15
5.1.1 Preliminary preparation.....	15
5.1.2 Test equipment	15
5.1.3 Uncertainty of measurements and conformance with specifications.....	15
5.1.4 Sequence of testing	16
5.1.5 Visual inspection.....	16
5.2 Test environment and apparatus.....	16
5.2.1 Ambient conditions	16
5.2.2 Floor surface	16
5.2.3 Test mattress	16
5.2.4 Loading pad	17
5.2.5 Impactor	17
5.2.6 Cones for determining distances between elements	19
5.2.7 Test bed board.....	19
5.3 Stability.....	19
5.3.1 Requirements for stability	19
5.3.2 Test methods for stability	19
5.4 Strength and durability	22
5.4.1 Requirements for downwards static load onto beds/detachable bed boards/bed lifts22	
5.4.2 Test methods for downwards static load onto beds/detachable bed boards/bed lifts22	
5.4.3 Requirements for the durability of beds/detachable bed boards/bed lifts	22
5.4.4 Test methods for the durability of beds/detachable bed boards/bed lifts	23
5.4.5 Requirements for vertical impact onto beds/detachable bed boards/bed lifts	23
5.4.6 Test methods for vertical impact onto beds/detachable bed boards/bed lifts.....	23
5.4.7 Requirements for the deflection of the bed side.....	24
5.4.8 Test methods for the deflection of the bed side	24
5.4.9 Requirements for the height adjustment mechanisms	25
5.4.10 Test methods for the height adjustment mechanisms	25
5.4.11 Requirements for the strength and rigidity of side rails and grab handles.....	25
5.4.12 Test methods for the strength and rigidity of side rails and grab handles	25
5.4.13 Requirements for the lifting pole	26
5.4.14 Test methods for the lifting pole	27
5.4.15 Requirements for fixation of the bed lift to the bed.....	27
5.4.16 Test method for fixation of the bed lift to the bed	27
5.5 Linear and angular dimensions	27
5.5.1 Height of bed.....	27
5.5.2 Height of seat section	27
5.5.3 Under bed clearance	28
5.5.4 Angles of mattress support platform.....	29
5.5.5 Dimensions of side rails and grab handles	32

5.5.6	Test methods for determining the distance between any elements of the side rail/grab handle and between any elements of the side rail/grab handle and their supporting structure	34
5.5.7	Distances to the handle of the lifting pole.....	34
5.5.8	Dimensions of the control unit	34
5.5.9	Dimensions of handles and pedals	34
5.6	Operating forces	34
5.7	Operating speed and time	35
5.8	Additional requirements regarding stand up beds.....	35
5.8.1	Stand-up beds intended for transfer from the bed in up-right position.....	36
5.8.2	Test methods for straps for stand-up beds.....	36
5.8.3	Test methods for the stability of stand up beds.....	36
5.9	Immobilization	37
5.10	Test method for immobilization.....	37
5.11	Electrotechnical requirements	37
5.12	EMC requirements	37
5.12.1	Emission	38
5.12.2	Immunity.....	38
5.13	Noise	38
6	Instructions for use	38
7	Marking	39
	Annex ZA (informative) Clauses of this European Standard addressing essential requirements or other provisions of EU Directives.	40

iTeh STANDARD PREVIEW (standards.iteh.ai)

SIST EN 1970:2000

<https://standards.iteh.ai/catalog/standards/sist/f06df021-b87a-4d2b-9fa9-dea9f7b34497/sist-en-1970-2000>

Foreword

This European Standard has been prepared by Technical Committee CEN/TC 293 "Technical aids for disabled persons", the secretariat of which is held by SIS.

This European Standard shall be given the status of a national standard, either by publication of an identical text or by endorsement, at the latest by December 2000, and conflicting national standards shall be withdrawn at the latest by December 2000.

This European Standard has been prepared under a mandate given to CEN by the European Commission and the European Free Trade Association, and supports essential requirements of EU Directive(s).

For relationship with EU Directive(s), see informative Annex ZA, which is an integral part of this standard.

According to the CEN/CENELEC Internal Regulations, the national standards organizations of the following countries are bound to implement this European Standard: Austria, Belgium, Czech Republic, Denmark, Finland, France, Germany, Greece, Iceland, Ireland, Italy, Luxembourg, Netherlands, Norway, Portugal, Spain, Sweden, Switzerland and the United Kingdom.

This standard provides one means to demonstrate that adjustable beds for disabled persons, which are also medical devices, conform to the essential requirements outlined in general terms in Annex 1 of the EU Directive 93/42/EEC. It is not intended to provide a means to show conformity with the requirements of any other directive.

There are three levels of European Standards dealing with technical aids for disabled persons. These are as follows, with level 1 being the highest:

- Level 1: General requirements for technical aids
- Level 2: Particular requirements for families of technical aids
- Level 3: Specific requirements for types of technical aids.

Where standards for particular aids or groups of aids exist (level 2 or 3), the requirements of lower level standards take precedence over higher level standards. Therefore, to address all requirements for a particular aid, it is necessary to start with standards of the lowest available standard.

This is a combined level 2- and 3-standard (lowest possible) for adjustable beds for disabled persons, which are also medical devices, as specified in the scope.

Introduction

This standard is intended to apply to the most common products, but certain products will have to fulfil further or other requirements, e.g. regarding ergonomics, depending on the product in question. The risk analysis should be used for determining if further or other requirements should be addressed for each specific product.

Due to the dissimilarity of disabilities to be alleviated, it is not possible to specify requirements for adjustable beds for disabled persons in such a way that any bed of this type is covered. The present standard is therefore intended to cover the major part of adjustable beds for disabled persons. Certain beds, e.g. those designed to meet special needs, might need to fulfil other or further requirements, e.g. regarding ergonomics or EMC, than specified in this standard.

Beds covered by the present standard differ from beds covered by the IEC standard on electrically operated hospital beds, e. g. due the following characteristics:

- beds for disabled persons are intended to be used instead of domestic beds for permanent use, with the intention of alleviating or compensating for a disability or handicap and to facilitate better working conditions for attendants,
- beds for disabled persons do not require the same level of strength and cleaning as hospital beds, due to the different application,
- beds for disabled persons do not require the same electrical performance as hospital beds due to the different application.

iTeh STANDARD PREVIEW
(standards.iteh.ai)

[SIST EN 1970:2000](#)

<https://standards.iteh.ai/catalog/standards/sist/f06df021-b87a-4d2b-9fa9-dea9f7b34497/sist-en-1970-2000>

1 Scope

This standard specifies essential requirements and related test methods for non-electrically and electrically operated adjustable beds, including detachable bed boards, bed lifts, side rails, grab handles and lifting poles intended to be used by disabled persons to alleviate or compensate for a disability or handicap.

The standard also applies to stand up beds.

The standard does not apply to lateral tilt beds.

The standard does not apply to beds intended for use in the diagnosis, treatment or monitoring of patients under medical supervision (covered by EN 60601-2-38 for electrically operated hospital beds).

The standard does not apply to ordinary domestic beds, beds intended for children under 12 years of age, and mattresses.

The requirements in this standard do not take into account extreme heavy duty use of the bed.

2 Normative references

This European Standard incorporates by dated or undated reference, provisions from other publications. These normative references are cited at the appropriate places in the text and the publications are listed hereafter. For dated references, subsequent amendments to or revisions of any of these publications apply to this European Standard, only when incorporated in it by amendment or revision. For undated references the latest edition of the publication referred to applies (including amendments).

EN 1441	Medical devices - Risk analysis
EN 60529	Degrees of protection provided by enclosures (IP code) (IEC 60529:1989)
EN 60601-1	Medical electrical equipment - Part 1: General requirements for safety
EN 60601-1-2:1993	Medical electrical equipment - Part 1: General requirements for safety - 2: Collateral standard: Electromagnetic compatibility - Requirements and test methods
EN 61000-3-2	Electromagnetic compatibility (EMC) - Part 3: Limits - Section 2: Limits for harmonic current emissions (equipment input current ≤ 16 A per phase)
EN 61000-3-3	Electromagnetic compatibility (EMC) - Part 3: Limits - Section 3: Limitation of voltage fluctuation and flicker in low-voltage supply systems for equipment input current ≤ 16 A
EN 61000-4-3	Electromagnetic compatibility (EMC) - Part 4: Testing and measurement techniques - Section 3: Radiated radio-frequency, electromagnetic field immunity test

EN ISO 3746	Acoustics - Determination of sound power levels of noise sources using sound pressure - Survey method using an enveloping measurement surface over a reflecting plane (ISO 3746:1995)
EN ISO 14253-1	Geometrical Product Specifications (GPS) - Inspection by measurement of workpieces and measuring equipment - Part 1: Decision rules for proving conformance or non-conformance with specifications (ISO 14253-1:1998)
ISO 2439	Flexible cellular polymeric materials - Determination of hardness (indentation technique)
GUM	Guide to the Expression of Uncertainty in Measurement - GUM - 1st edition 1995 issued by BIPM, IEC, ISO, IUPAC, IUPAP, OIML - ISBN 92-67-10188-9

3 Terms and definitions

For the purposes of this standard the following terms and definitions apply:

3.1

Adjustable bed

Bed with one or more sections of the mattress support platform that can be adjusted in height and/or angle. The adjustment can be non-electrically or electrically operated.

NOTE: Whenever the term "bed" is used it comprises detachable bed boards, bed lifts and accessories.

3.2

Bed lift

Height adjustable undercarriages on which a standard bed can be mounted, thus serving as a height adjustable bed.

3.3

Stand up bed

Bed capable of raising the disabled person to a standing position.

3.4

Knock-down bed

Bed intended to be disassembled into few main parts for storage or transportation.

3.5

Safe working load (SWL)

Maximum permissible load (of disabled person, mattress, bed linen and accessories and those parts of the bed intended to be lifted by the bed lift) to operate the bed safely.

3.6

Grab handle

Supporting structure for the disabled when getting in and out of bed, and when turning from one side to the other in bed.

3.7

Side rail

Fold-away or removable rail intended to prevent the disabled to fall out of the bed.

3.8

Lifting pole: Device suspended above the bed intended to enable the disabled person to change position by gripping it.

3.9

Control unit: Device that controls the drives that activate various functions of electrically operated beds.

3.10

Hold-to-run control device: Control device which initiates and maintains operation of operating elements, only as long as the manual control (actuator) is actuated. The manual control (actuator) returns automatically to the stop position when released.

3.11

Under bed clearance: Space beneath the bedstead base which is not occupied by the castors, legs or other constructional parts.

3.12

Normal reach for fingers: Parts of the upper bed and parts under the bed (see figure 1) which are placed at a distance of less than 200 mm from upper/lower part of the outer edge of the bed board as shown in figure 1.

3.13

Normal reach for feet: Parts under the bed which are placed at a distance of less than 120 mm from the vertical line of the outer edge of the bed board.

3.14

Moving parts: Parts that are movable in relation to each other or in relation to a fixed part.

3.15

Bed board: Mattress support platform and its frame, if any.

The nomenclature is given in figures 2 to 5 (the figures are only intended to illustrate the nomenclature).

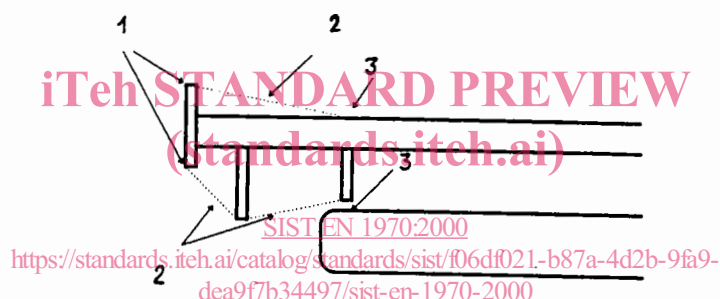

1. Outer edge of bed board
2. Distance min. 200 mm
3. Potential squeezing or shearing point

Figure 1 - Normal reach for fingers

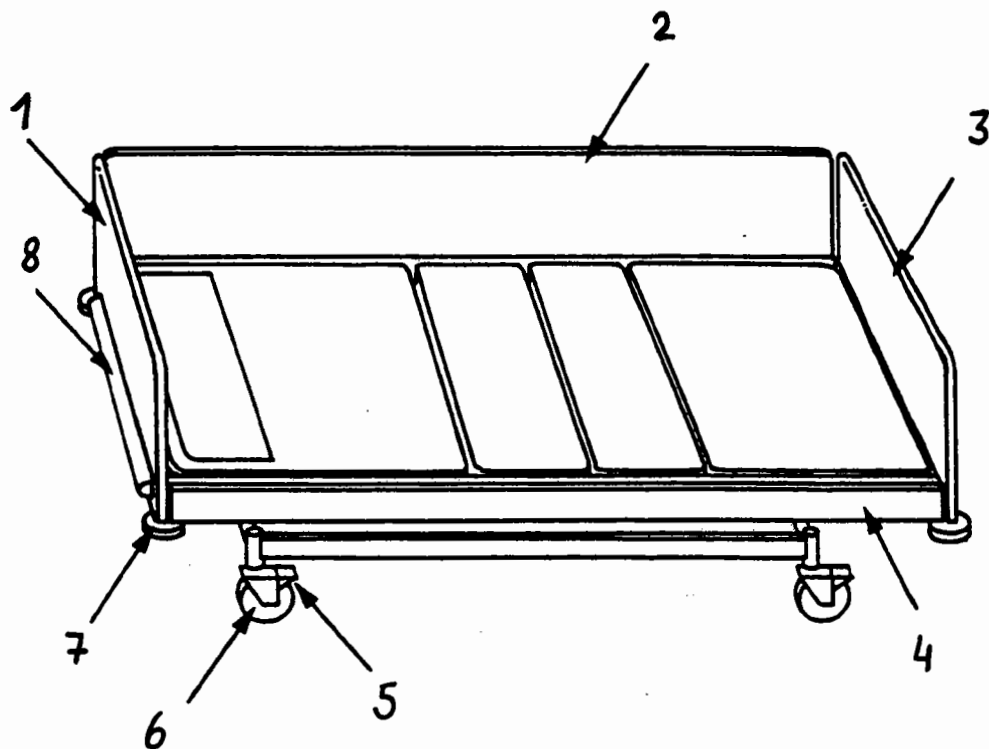

1. Head and panel
2. High side panel
3. Foot and panel
4. Side structure
5. Wheel lock
6. Castor
7. Roller buffer
8. Bumper bar

iTeh STANDARD PREVIEW
(standards.iteh.ai)

Figure 2 - Nomenclature of bed (example, schematic presentation only)

<https://standards.iteh.ai/catalog/standards/sist/f06df021-b87a-4d2b-9fa9-dea9f7b34497/sist-en-1970-2000>

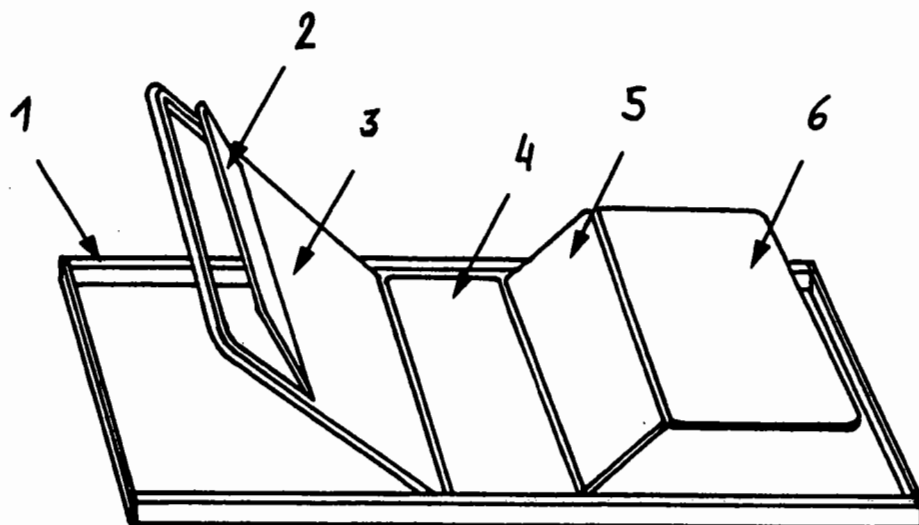

1. Bed board frame
2. Head rest section
3. Back rest section
4. Seat section
5. Upper leg section
6. Lower leg section

**Figure 3 - Nomenclature of detachable bed board
(example, schematic presentation only)**

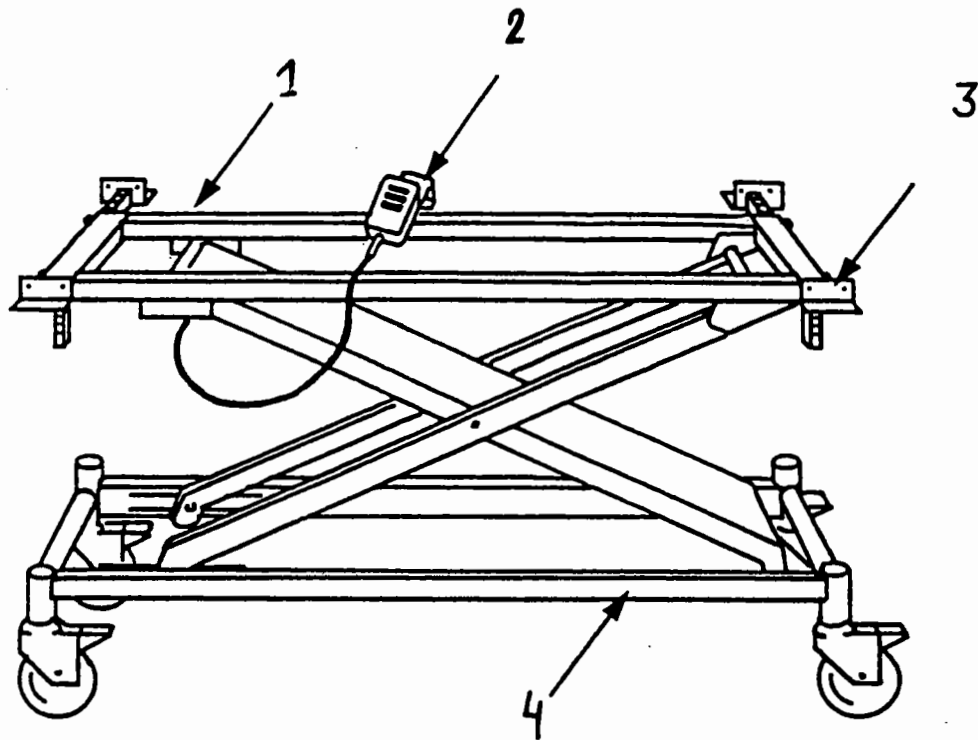

1. Upper carriage frame
2. Control unit
3. Attachment for the bed board
4. Under carriage frame

STANDARD PREVIEW
(standards.iteh.ai)

Figure 4 - Nomenclature of bed lift (example, schematic presentation only)

<https://standards.iteh.ai/catalog/standards/sist/f06df021-b87a-4d2b-9fa9-dea9f7b34497/sist-en-1970-2000>