



Designation: A 1013 – 00

Standard Test Method for High-Frequency (10 kHz-1 MHz) Core Loss of Soft Magnetic Core Components at Controlled Temperatures Using the Voltmeter-Ammeter-Wattmeter Method¹

This standard is issued under the fixed designation A 1013; the number immediately following the designation indicates the year of original adoption or, in the case of revision, the year of last revision. A number in parentheses indicates the year of last reapproval. A superscript epsilon (ϵ) indicates an editorial change since the last revision or reapproval.

1. Scope

1.1 This test method covers the equipment, procedures, and measurement of core loss of either toroidal or mated soft magnetic core components, such as soft ferrite cores, iron powder cores, and so forth, over ranges of controlled ambient temperatures typically from -20 to $+120^{\circ}\text{C}$, frequencies from 10 kHz to 1 MHz, under sinusoidal flux conditions.

1.2 *This standard does not purport to address all of the safety concerns, if any, associated with its use. It is the responsibility of the user of this standard to establish appropriate safety and health practices and determine the applicability of regulatory limitations prior to use.*

1.3 The values and equations stated in customary (cgs-emu and inch-pound) of SI units are to be regarded separately as standard. Within this test method, SI units are shown in brackets except for the sections concerning calculations where there are separate sections for the respective unit systems. The values stated in each system may not be exact equivalents; therefore, each system shall be used independently of the other. Combining values from the two systems may result in nonconformance with this standard.

2. Referenced Documents

2.1 ASTM Standards:

A 34/A 34M Practice for Sampling and Procurement Testing of Magnetic Materials²

A 340 Terminology of Symbols and Definitions Relating to Magnetic Testing²

E 177 Practice for Use of the Terms Precision and Bias in ASTM Test Methods³

3. Terminology

3.1 The definitions of terms, symbols, and conversion factors relating to magnetic testing, used in this test method, are found in Terminology A 340.

3.2 Definitions of Terms Specific to This Standard:

3.2.1 *bifilar transformer*—a transformer in which the turns of the primary and secondary windings are wound together side by side and in the same direction. This type of winding results in near unity coupling, so that there is a very efficient transfer of energy from primary to secondary.

3.2.2 *core-loss density, P_{cd}* —core loss per unit volume in mW/cm^3 [W/m^3].

3.2.3 *effective permeability*—the relative permeability of a magnetic circuit including the effect of air gaps in the magnetic path length.

3.2.4 *mated core set*—two or more core segments assembled with the magnetic flux path perpendicular to the mating surface.

4. Significance and Use

4.1 This test method is designed for testing of either toroidal or mated soft magnetic core components over a range of temperatures, frequencies, and flux densities.

4.2 The reproducibility and repeatability of this test method are such that it is suitable for design, specification acceptance, service evaluation, and research and development.

5. Apparatus

5.1 The apparatus shall consist of as many of the component parts as shown in the block circuit diagrams (Figs. 1 and 2) and described as follows and in the appendix, as required to perform the tests.

5.2 *Signal Generator*—A low distortion sine wave signal generator is required. The frequency accuracy of the signal generator should be within $\pm 0.1\%$ with an output amplitude range from 1-mV to 10-V p-p.

5.3 *Broadband Power Amplifier*, capable of amplifying the output of the signal source by 50 dB.

5.4 *Volt-Amp-Watt Meter with Current Transformer*, ac-coupled, broadband, power factor independent, true RMS reading instrument. Voltage channel minimum input impedance 1 M Ω , voltage range from 2 to 100 V, current ranges from 5 mA to 5A, power ranges from 100 mW to 500 W. The full-scale accuracy of the wattmeter shall not exceed 0.75 % of the product of the input voltage and current ranges.

¹ This test method is under the jurisdiction of ASTM Committee A06 on Magnetic Properties and is the direct responsibility of Subcommittee A06.01 on Test Methods.

Current edition approved Oct. 10, 2000. Published January 2001.

² *Annual Book of ASTM Standards*, Vol 03.04.

³ *Annual Book of ASTM Standards*, Vol 14.02.

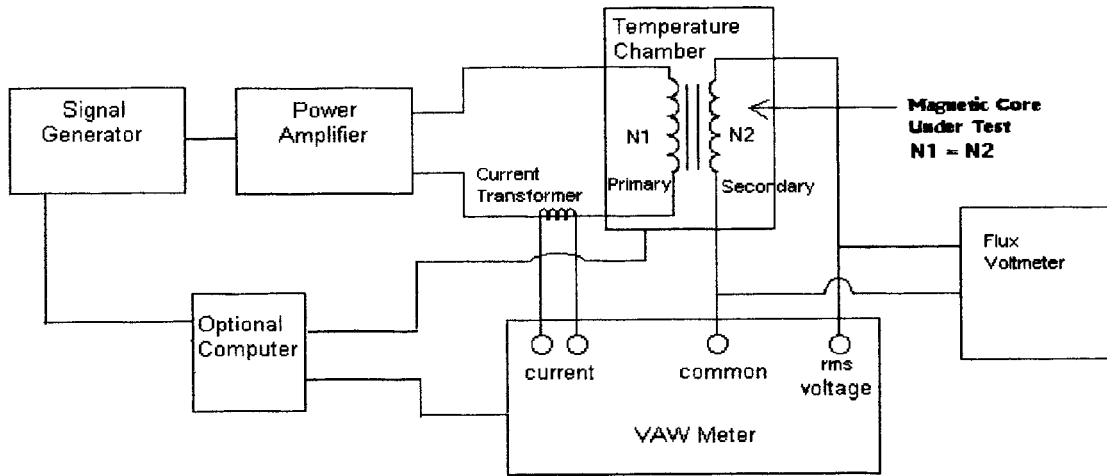

FIG. 1 Basic Circuit for VAW Meter Method Using Primary and Secondary Windings

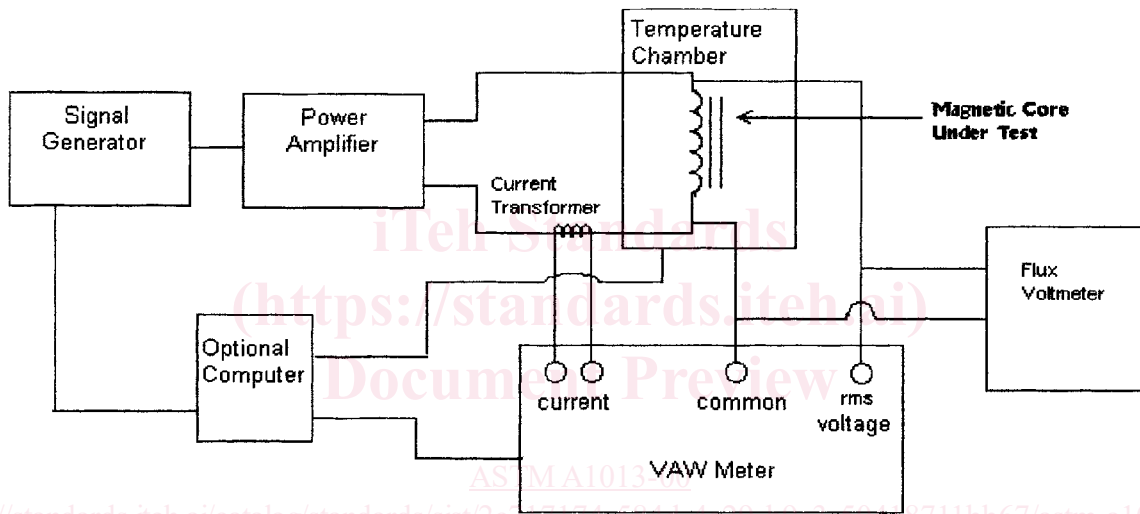

FIG. 2 Optional Circuit for VAW Meter Method Using One Winding Only (See 7.1)

5.5 *Flux Voltmeter*—A full-wave true-averaging voltmeter with scale reading in average volts times 1.111 so that its indications will be identical with those of a true rms voltmeter on a pure sinusoidal voltage. Input impedance of at least 2 M Ω . To produce the estimated precision of test under this test method, the full-scale meter errors shall not exceed 0.25 %.

5.6 *Temperature Chamber*, heated with electric elements, cooled by injecting liquid CO₂ or liquid nitrogen into the air stream through an expansion nozzle or equivalent methods.

5.7 *Temperature with Platinum RTD or Type T Thermocouple*.

5.8 *Optional*—Personal computer with appropriate I/O to control equipment and collect data.

6. Test Core Component

6.1 The test core component can be of any magnetic material (soft ferrite, iron powder, and so forth). The effective permeability of the material must be sufficiently high so that the test core component can be driven to the desired flux density with the available test equipment (within the power amplifier limitations).

6.2 When testing for material properties, the cross-sectional area of the test core component shall be uniform throughout its entire magnetic path length. The core may be of any shape. Shapes with nonuniform cross-sectional areas within their magnetic path length can be tested for specific core shape performance comparisons; however, the core-loss density will not be accurate, since the flux density and core loss vary throughout the magnetic path length and are not uniform.

6.3 Mated core set assembled around a prewound coil can be used, as well as toroidal cores.

6.3.1 Mating surfaces must be ground smooth and flat to minimize air gaps. Air gaps cause reluctance in the flux path and cause flux to fringe, both of which contribute to higher measured losses.

6.3.2 Clamping pressure for the mated core set needs to be sufficient to hold the cores together with minimum air gaps but not so strong that it affects the properties of the material through the creation of stress-magnetostriction anisotropy. A pressure of 5 lb/in.² [35 kPa] is recommended where the area is the area of the mating surfaces.