



Standard Test Method for Evaluation of Automotive Engine Oils for Inhibition of Deposit Formation in a Spark-Ignition Internal Combustion Engine Fueled with Gasoline and Operated Under Low- Temperature, Light-Duty Conditions¹

This standard is issued under the fixed designation D 6593; the number immediately following the designation indicates the year of original adoption or, in the case of revision, the year of last revision. A number in parentheses indicates the year of last reapproval. A superscript epsilon (ϵ) indicates an editorial change since the last revision or reapproval.

1. Scope

1.1 This test method is commonly referred to as the Sequence VG test² and has been correlated with vehicles used in stop-and-go service prior to 1996, particularly with regard to sludge and varnish formation.³ It is one of the test methods required to evaluate oils intended to satisfy the API SL performance category.

1.2 The values stated in SI units are to be regarded as standard.

1.3 *This standard does not purport to address all of the safety concerns, if any, associated with its use. It is the responsibility of the user of this standard to establish appropriate safety and health practices and determine the applicability of regulatory limitations prior to use.* Specific hazard statements are given in 7.7, 7.10.2.2, 8.3.4.2, 8.4.4.3, 9.2.6, 9.3.4.5, 9.6.1.2, 12.1.1.7, 12.2.1.4, and Annex A1.

1.4 A Table of Contents follows:

Scope	1
Referenced Documents	2
ASTM Standards	2.1
SAE Standards	2.2
ANSI Standard	2.3
Terminology	3
Definitions	3.1
Definitions of Terms Specific to This Standard	3.2
Summary of Test Method	4
Significance and Use	5
Apparatus-General Description	6
Apparatus-The Test Engine	7
Sequence VG Test Engine	7.1

Required New Engine Parts	7.2
Reusable Engine Parts	7.3
Specially Fabricated Engine Parts	7.4
Special Engine Measurement and Assembly Equipment	7.5
Miscellaneous Engine Components-Preparation	7.6
Solvents and Cleaners Required	7.7
Assembling the Test Engine-Preparations	7.8
Assembling the Test Engine-Installations	7.9
Engine Installation on the Test Stand	7.10
Engine Fluids-Supply/Discharge Systems	8
Intake Air	8.1
Fuel and Fuel System	8.2
Engine Oil and Engine Oil System	8.3
Coolants	8.4
Measurement Instrumentation	9
Temperatures	9.1
Pressures	9.2
Flow Rates	9.3
Fuel Consumption	9.4
Speed and Load	9.5
Exhaust Gas	9.6
Humidity	9.7
Miscellaneous Laboratory Equipment	10
Test Stand Calibration	11
Test Procedure	12
Pre-Test Procedure	12.1
Engine Operating Procedure	12.2
Periodic Measurements and Functions	12.3
Special Maintenance Procedures	12.4
Diagnostic Data Review	12.5
End of Test Procedure	12.6
Interpretation of Test Results	13
Parts Rating Area-Environment	13.1
Sludge Ratings	13.2
Varnish Ratings	13.3
Clogging	13.4
Sticking	13.5
Used Oil Analyses	13.6
Assessment of Test Validity	14
General	14.1
Average Exhaust Gas NO _x Levels	14.2
Used Oil Analyses-Interpretation	14.3
Blowby Flow Rate	14.4
Manifold Absolute Pressure	14.5
Fuel Consumption Rate	14.6
Oil Consumption	14.7
Engine Parts Replacement	14.8
Quality Index and Deviation Percentage	14.9
Final Test Report	15
Report Forms	15.1
Photographs	15.2
Precision and Bias	16

¹ This test method is under the jurisdiction of ASTM Committee D02 on Petroleum Products and Lubricants and is the direct responsibility of Subcommittee D02.B0.01 on Passenger Car Engine Oils.

Current edition approved Nov. 10, 2001. Published January 2002. Originally published as D 6593 – 00. Last previous edition D 6593 – 00.

² Until the next revision of this test method, the ASTM Test Monitoring Center will update changes in the test method by means of information letters. Information letters may be obtained from the ASTM Test Monitoring Center, 6555 Penn Ave., Pittsburgh, PA 15206-4489. Attention: Administrator. This edition incorporates revisions in all information Letters through No. 01-2.

³ Supporting data are available from ASTM International Headquarters. Research RR: D02-1472.

Keywords	17
ANNEXES	
Safety Precautions	Annex A1
Control and Data Acquisition Requirements	Annex A2
Detailed Specifications and Photographs of Apparatus	Annex A3
Special Service Tools for the Test Engine	Annex A4
Engine Parts Number Listing	Annex A5
External Oil Heat Exchanger Cleaning Technique	Annex A6
Final Report Forms	Annex A7
Typical 4.6L Dipstick Calibration	Annex A8
Critical Part Supplier List	Annex A9
Oil Sampling, Addition and Leveling Record	Annex A10
Rating Worksheets	Annex A11
Fuel Injector Flow Measurements	Annex A12
APPENDIXES	
Suggested Engine Measurement Sheets	Appendix X1
Sources of Materials and Information	Appendix X2
Description of Scott Quarterly Gas Audit Service	Appendix X3

2. Referenced Documents

2.1 ASTM Standards:

- D 86 Test Method for Distillation of Petroleum Products at Atmospheric Pressure⁴
- D 287 Test Method for API Gravity of Crude Petroleum and Petroleum Products (Hydrometer Method)⁴
- D 323 Test Method for Vapor Pressure of Petroleum Products (Reid Method)⁴
- D 381 Test Method for Gum Content in Fuels by Jet Evaporation⁴
- D 445 Test Method for Kinematic Viscosity of Transparent and Opaque Liquids (the Calculation of Dynamic Viscosity)⁴
- D 525 Test Method for Oxidation Stability of Gasoline (Induction Period Method)⁴
- D 873 Test Method for Oxidation Stability of Aviation Fuels (Potential Residue Method)⁴
- D 893 Test Method for Insolubles in Used Lubricating Oils⁴
- D 1266 Test Method for Sulfur in Petroleum Products (Lamp Method)⁴
- D 1298 Test Method for Density, Relative Density (Specific Gravity) or API Gravity of Crude Petroleum and Liquid Petroleum Products by Hydrometer Method⁴
- D 2622 Test Method for Sulfur in Petroleum Products by Wavelength Dispersive X-ray Fluorescence Spectrometry⁵
- D 2789 Test Method for Hydrocarbon Types in Low Olefinic Gasoline By Mass Spectrometry⁵
- D 3237 Test Method for Lead in Gasoline by Atomic Absorption Spectrometry⁵
- D 3525 Test Method for Gasoline Diluent in Used Gasoline Engine Oils by Gas Chromatography⁵
- D 3606 Test Method for Determination of Benzene and Toluene in Finished Motor and Aviation Gasoline by Gas Chromatography⁵
- D 4057 Practice for Manual Sampling of Petroleum and Petroleum Products⁵
- D 4175 Terminology Relating to Petroleum, Petroleum Products, and Lubricants⁵
- D 4294 Test Method for Sulfur in Petroleum and Petroleum Products by Energy-Dispersive X-ray Fluorescence Spectrometry⁵

- D 4485 Specification for Performance of Engine Oils⁵
- D 4739 Test Method for Base Number Determination by Potentiometric Titration⁵
- D 4863 Test Method for Determination of Lubricity of Two-Stroke-Cycle Gasoline Engine Lubricants⁵
- D 5059 Test Method for Lead in Gasoline by X-Ray Spectroscopy⁶
- D 5185 Test Method for Determination of Additive Elements, Wear Metals, and Contaminants in Used Lubricating Oils and Determination of Selected Elements in Base Oils by Inductively Coupled Plasma Atomic Emissions Spectrometry (ICP-AES)⁶
- D 5302 Test Method for Evaluation of Automotive Engine Oils for Inhibition of Deposit Formation and Wear in a Spark-Ignition Internal Combustion Engine Fueled with Gasoline and Operated Under Low-Temperature, Light-Duty Conditions⁶
- D 5844 Test Method for Evaluation of Automotive Engine Oils for Inhibition of Rusting (Sequence IID)⁶
- D 5862 Test Method for Evaluation of Engine Oils in Two-Stroke Cycle Turbo-Supercharged 692TA Diesel Engine⁶
- D 6304 Test Method for Determination of Water in Petroleum Products, Lubricating Oils, and Additives by Coulometric Karl Fischer Titration⁷
- E 29 Practice for Using Significant Digits in Test Data to Determine Conformance with Specifications⁸
- G 40 Terminology Relating to Erosion and Wear⁹

2.2 SAE Standards:

- SAE J254 Instrumentation and Techniques for Exhaust Gas Emissions Measurement¹⁰

2.3 ANSI Standard:

- ANSI MC96.1 Temperature Measurement—Thermocouples¹¹

3. Terminology

3.1 Definitions:

3.1.1 *air-fuel ratio, n*—in internal combustion engines, the mass ratio of air-to-fuel in the mixture being inducted into the combustion chambers. **D 5302**

3.1.1.1 *Discussion*—In this test method, air-fuel ratio (AFR), is controlled by the EEC IV engine control module.

3.1.2 *blowby, n*—in internal combustion engines, the combustion products and unburned air and fuel mixture that enter the crankcase. **D 5302**

3.1.3 *cold-stuck piston ring, n*—in internal combustion engines, a piston ring that is stuck when the piston and ring are at room temperature, but inspection shows that it was free during engine operation.

3.1.3.1 *Discussion*—A cold-stuck piston ring cannot be moved with moderate finger pressure. It is characterized by a

⁶ Annual Book of ASTM Standards, Vol 05.03.

⁷ Annual Book of ASTM Standards, Vol 05.04.

⁸ Annual Book of ASTM Standards, Vol 14.02.

⁹ Annual Book of ASTM Standards, Vol 03.02.

¹⁰ Available from Society of Automotive Engineers, 400 Commonwealth Dr., Warrendale, PA 15096.

¹¹ Available from American National Standards Institute, 25 W. 43rd St., 4th Floor, New York, NY 10036.

⁴ Annual Book of ASTM Standards, Vol 05.01.

⁵ Annual Book of ASTM Standards, Vol 05.02.



polished face over its entire circumference, indicating essentially no blowby passed over the ring face during engine operation. **D 5302**

3.1.4 *debris, n—in internal combustion engines*, solid contaminant materials unintentionally introduced into the engine or resulting from wear. **D 5862**

3.1.4.1 *Discussion*—Examples include such things as gasket material, silicone sealer, towel threads, and metal particles.

3.1.5 *free piston ring, n—in internal combustion engines*, a piston ring that will fall in its groove under its own weight when the piston with the ring in a horizontal plane, is turned 90° (putting the ring in a vertical plane). **D 5862**

3.1.5.1 *Discussion*—A slight touch to overcome static friction is permissible.

3.1.6 *hot-stuck piston ring, n—in internal combustion engines*, a piston ring that is stuck when the piston and ring are at room temperature, and inspection shows that it was stuck during engine operation. **D 5302**

3.1.6.1 *Discussion*—The portion of the ring that is stuck cannot be moved with moderate finger pressure. A hot-stuck piston ring is characterized by varnish or carbon across some portion of its face, indicating that portion of the ring was not contacting the cylinder wall during engine operation.

3.1.7 *filtering, n—in data acquisition*, a means of attenuating signals in a given frequency range. They can be mechanical (volume tank, spring, mass) or electrical (capacitance, inductance) or digital (mathematical formulas), or a combination thereof. Typically, a low-pass filter attenuates the unwanted high frequency noise.

3.1.8 *knock, n—in a spark ignition engine*, abnormal combustion, often producing audible sound, caused by autoignition of the air/fuel mixture. **D 4175**

3.1.9 *reading, n—in data acquisition*, The reduction of data points that represent the operating conditions observed in the time period as defined in the test procedure.

3.1.10 *out of specification data, n—in data acquisition*, Sampled value of a monitored test parameter that has deviated beyond the procedural limits

3.1.11 *scoring, n—in tribology*, a severe form of wear characterized by the formation of extensive grooves and scratches in the direction of sliding. **G 40**

3.1.12 *scuffing, n—in lubrication*, damage caused by instantaneous localized welding between surfaces in relative motion that does not result in immobilization of the parts. **D 4863**

3.1.13 *sludge, n—in internal combustion engines*, a deposit, principally composed of insoluble resins and oxidation products from fuel combustion and the lubricant, that does not drain from engine parts but can be removed by wiping with a cloth. **D 5302**

3.1.14 *tight piston ring, n—in internal combustion engines*, a piston ring that will not fall in its groove under the force of its own weight when the piston, with the ring in a horizontal plane, is turned 90° (putting the ring in a vertical plane); by subsequent application of moderate finger pressure, the ring will be displaced. **D 5862**

3.1.15 *time constant, n—in data acquisition*, A value which represents a measure of the time response of a system. For a first order system responding to a step change input, it is the

time required for the output to reach 63.2 % of its final value.

3.1.16 *varnish, n—in internal combustion engines*, a hard, dry, generally lustrous deposit that can be removed by solvents but not by wiping with a cloth. **D 5302**

3.1.17 *wear, n—loss of material from, or relocation of material on, a surface.* **D 5844**

3.1.17.1 *Discussion*—Wear generally occurs between two surfaces moving relative to each other, and is the result of mechanical or chemical action or by a combination of mechanical and chemical actions.

3.2 *Definitions of Terms Specific to This Standard:*

3.2.1 *clogging, n—the restriction of a flow path due to the accumulation of material along the flow path boundaries.*

3.2.2 *enrichment, n—in internal combustion engine operation*, a fuel consumption rate in excess of that which would achieve a stoichiometric air-to-fuel ratio.

3.2.2.1 *Discussion*—Enrichment is usually indicated by elevated CO levels and can also be detected with an extended range air/fuel ratio sensor.

3.2.3 *low-temperature, light-duty conditions, n—indicative of engine oil and coolant temperatures that average below normal warmed-up temperatures, and engine speeds and power outputs that average below those encountered in typical highway driving.*

3.2.4 *ramping, n—the prescribed rate of change of a variable when one set of operating conditions is changed to another set of operating conditions.*

4. Summary of Test Method

4.1 Each test engine is assembled with many new parts and essentially all aspects of assembly are specified in detail.

4.2 The test stand is equipped to control speed, load, AFR, and various other operating parameters.

4.3 The test is run for a total of 216 h, consisting of 54 cycles of 4 h each. Each cycle consists of three stages.

4.4 While the operating conditions are varied within each cycle, overall they can be characterized as a mixture of low-temperature and moderate-temperature, light and medium duty operating conditions.

4.5 To accelerate deposit formation, the level of oxides of nitrogen in the blowby and the rate of blowby into the crankcase are significantly increased. The fresh air breathing of the crankcase is eliminated and the oil and coolant temperatures are lowered to induce condensation of water and fuel.

4.6 The performance of the test engine oil is evaluated at the end of the test by dismantling the engine and measuring the level of deposit formation.

5. Significance and Use

5.1 This test method is used to evaluate an automotive engine oil's control of engine deposits under operating conditions deliberately selected to accelerate deposit formation. This test method was correlated with field service data, determined from side-by-side comparisons of two or more oils in police, taxi fleets, and delivery van services. The same field service oils were then used in developing the operating conditions of this test procedure.

5.2 This test method, along with other test methods, defines the minimum performance level of the API Category SL

(detailed information about this category is included in Specification D 4485). This test method is also incorporated in automobile manufacturers' factory-fill specifications.

5.3 The basic engine used in this test method is representative of many that are in modern automobiles. This factor, along with the accelerated operating conditions, should be considered when interpreting test results.

6. Apparatus-General Description

6.1 The test engine is a Ford 4.6L, spark ignition, four stroke, eight-cylinder V configuration engine. Features of this engine include an overhead camshaft, a cross-flow fast-burn cylinder head design, two valves per cylinder and electronic port fuel injection. It is based on the Ford Motor Co. 4.6L EFI Crown Victoria¹² passenger car engine.

6.2 Configure the test stand to accept a Ford 4.6L two valves per cylinder engine. All special equipment necessary for conducting this test is listed herein.

6.3 Use the appropriate air conditioning apparatus to control the temperature, pressure, and humidity of the intake air.

6.4 Use an appropriate fuel supply system (Fig. 1).

6.5 The control and data acquisition system shall meet the requirements listed in Annex A2.

7. Apparatus-The Test Engine

7.1 *Sequence VG Test Engine*—The test engine kit is available from the Ford Motor Co. (Annex A9.1). A detailed listing of all parts included in the kit is given in Annex A5. Orders for test engine hardware will be solicited yearly.

7.1.1 Non-rated parts can be replaced during the test, provided the reason for replacement was not oil related.

7.2 *Required New Engine Parts*—Use a new kit engine (see Annex A5), engine kit, and gasket kit for each test. Gaskets may be reused during each test as long as they remain serviceable.

7.3 *Reusable Engine Parts*—The parts listed in the test stand set up kit, engine dress kit, engine finish kit, and bolt kit can be reused (all of these can be used in numerous engine assemblies as long as they remain serviceable). See Annex A5. Timing chain covers can be used numerous times as long as they remain serviceable.

7.4 *Specially Fabricated Engine Parts*—The following subsections detail the specially fabricated engine parts required in this test method:

7.4.1 *Intake Air System* (see Fig. 2 and Figs. A3.1 and A3.2)—Intake air system shall use the stock Crown Victoria configuration with the air horn removed from the air cleaner.

7.4.2 *Camshaft Baffles* (see Annex A3.3)—These are fabricated for attachment to the under side of the rocker cover. The clearance between the edges of the baffle and the (rocker arm cover) RAC permits a limited splash flow of oil to the top of the baffle and the RAC. Therefore, the dimensional accuracy of the baffle is important to minimize the influence on test severity. The camshaft baffle is available from the supplier listed in Annex A9.2.

7.4.3 *Crankcase Oil Fill Port*—The crankcase oil fill port is

located towards the rear of the left rocker cover. See item 8 and 9 on Fig. A3.4.

7.4.4 *Dipstick and Dipstick Tube* (see Fig. A3.6)—The dipstick has been modified for accurate oil level measurements. The dipstick and dipstick tube are calibrated as a pair. If either part is replaced, then the pair shall be recalibrated. Use the dipstick and dipstick tube available from the supplier listed in Annex A9.2.

7.4.5 *Oil Pan*—Use a modified oil pan with removable baffles as shown in Fig. A3.7 from the supplier listed in Annex A9.2.

7.4.6 *Exhaust Manifold*—The required exhaust manifolds (see Annex A9.4), transition plates (see Annex A9.3) and exhaust system are shown in Figs. A3.15 and A3.16. A heated exhaust gas oxygen (HEGO) sensor is installed in the exhaust system after each exhaust manifold.

7.4.7 *Flywheel*—Use the flywheel listed in Annex A5.

7.4.8 *Rocker Arm Cover (RAC)*—The RAC is fabricated from stainless steel and incorporates a water jacket and bolt bosses for the camshaft baffle (see Figs. A3.3, A3.4 and A3.5). The RAC, bolts, and washers supplier is listed in Annex A9.2.

7.4.9 *Oil Filter*—Use a 60 μm screen type oil filter with a bypass (see Fig. A3.8) available from the supplier listed in Appendix X2.1.20.

7.4.10 *Oil Pan Insulation*—The oil pan is covered with a fiberglass insulation to reduce the effects of ambient temperature variations. The insulation supplier is listed in Annex A9.2.

7.5 *Special Engine Measurement and Assembly Equipment*—Items routinely used in the laboratory and workshop are not included. Use any special tools or equipment shown in the 1994 Ford Crown Victoria Service Manual¹³ for assembly. A list of these tools is shown in Annex A4. Complete any assembly instructions not detailed in Section 7 according to the instructions in the 1994 Ford Crown Victoria Service Manual.

7.5.1 *Piston Ring Positioner*—Use the piston ring positioner to locate the piston rings 28.5 mm (1.125 in.) from the cylinder block deck surface. This allows the compression rings to be positioned in a consistent location in the cylinder bore before measurement. Fabricate the positioner according to the details shown in Fig. A3.9.

7.5.2 *Piston Ring Grinder*—A ring grinder is required for adjusting ring gaps. A suitable ring grinder is noted in 7.8.5.1.

7.5.3 *PCV Valve Flow Rate Device*:

7.5.3.1 Use this device to verify the flow rate of the PCV valve before the test and measure the degree of clogging after the test. Fabricate the device according to the details shown in Fig. A3.10. The device shall have a full scale accuracy of 5 % and a resolution of 0.05 L/s (0.1 ft³/min) (see 7.6.7).

7.5.3.2 Calibrate the flow rate device once every six months against a standard traceable to NIST.

7.5.4 *Engine Service Tools*—A complete list of special tools for the test engine is shown in Annex A4. The tools are available from a Ford dealership. These are designed to aid in performing several service items, in addition to the following specific service items that require special tools to perform the

¹² Ford Crown Victoria is a product of the Ford Motor Co., Dearborn, MI 48121.

¹³ Available from Ford and Lincoln-Mercury Dealerships.

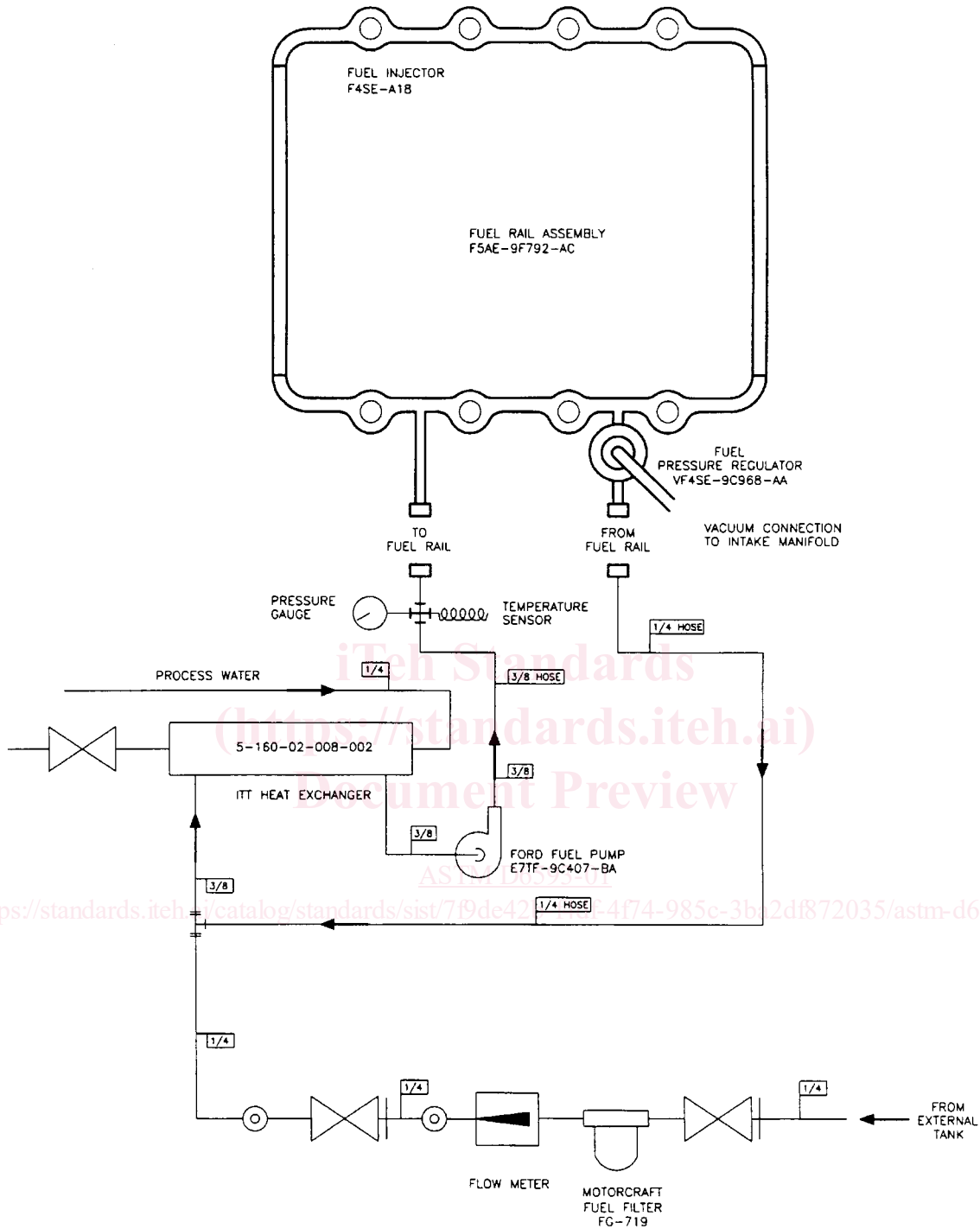

FIG. 1 Schematic of Engine Fuel System

functions indicated (if not self-explanatory).

7.5.5 *Master Bore*—Use a cylinder bore of 90.70 ± 0.03 mm as a master bore for determining top ring gap increase for the rings in cylinders 1 and 8. Using a master bore allows for consistent measurement of top ring gap increase at end-of-test. Maintain the master bore in a temperature controlled room.

7.5.6 *Oil Screen Blowdown Device*—Use the device available from the supplier listed in Annex A9.3 to blow a controlled amount of compressed air across the oil screen to

remove any oil that is retained on the oil screen after allowing it to drain.

7.6 *Miscellaneous Engine Components-Preparation:*

7.6.1 *Engine Build-Up and Measurement Area-Environment*—The ambient atmosphere of the engine buildup and measurement areas shall be reasonably free of contaminants. A relatively constant temperature (within $\pm 3^\circ\text{C}$) is necessary to ensure acceptable repeatability in the measurement of parts dimensions. Maintain the relative humidity at a

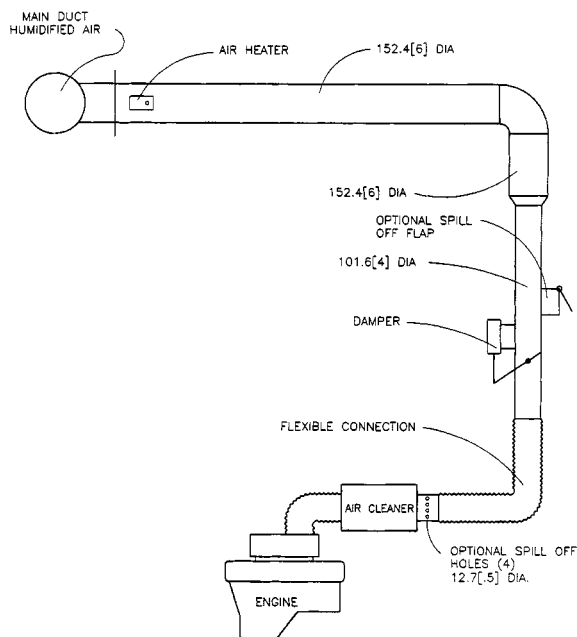

NOTE 1—Dimensions are in millimetres and (inches).
FIG. 2 Typical Test Stand Intake Air Supply System

nominal maximum of 50 % to prevent moisture forming on cold engine parts that are brought into the buildup or measurement areas.

7.6.2 Intake Manifold and Throttle Body:

7.6.2.1 The required intake manifold modifications entail blocking off the EGR port (block off plate shown in Fig. A3.11) and the coolant bypass port. Block coolant bypass port in intake manifold by tapping the hole and installing a ½ in. NPT pipe plug. Replace the idle air bypass motor with the idle load control system. A schematic of the system and the idle air block off plate are shown in Figs. A3.12 and A3.13, respectively.

7.6.2.2 Clean the butterfly and bore of the throttle body with aliphatic naphtha (7.7.1) and air-dry before each test. Do not disassemble the throttle body as this will cause excessive wear on the components. The idle air screw can be removed for the cleaning process. Fully close the idle air screw during test operation.

7.6.2.3 There is no specific life for the throttle body. However, the clearance between the bore and the butterfly will eventually increase and render the body unserviceable. When the clearance becomes too great to allow control of speed, load, and air-fuel ratio during Stage III, discard the throttle body.

7.6.3 Rocker Arm Cover:

7.6.3.1 Before each test, inspect the coolant jacket. If a deposit or film is present, then clean the RAC coolant jacket with a commercially available de-scaling cleaner, neutralizer, and inhibitor (8.4.4.1). An example of an acceptable cleaner is detailed in 7.7.3.

7.6.3.2 Submerge the RAC in agitated organic solvent (see 7.7.2) until clean (approximately 1 h). Rinse the parts thoroughly with hot water (> 60°C). Rinse the RAC with aliphatic naphtha (7.7.1) and allow to air-dry. Inspect the appearance of the interior surface of the RAC. If the before test rating is less

than ten on the CRC varnish rating scale (Manual 14),¹⁴ polish the interior surface lightly with No. 0 fine steel wool to achieve a dull finish. Rinse the cover with aliphatic naphtha (7.7.1) and allow to air-dry before use.

7.6.4 *Camshaft Baffle*—Submerge the camshaft baffles in agitated organic solvent (see 7.7.2) until clean (approximately 1 h). Rinse the parts thoroughly with hot water (> 60°C). Rinse the camshaft baffles with aliphatic naphtha (7.7.1) and allow to air-dry. Inspect the appearance of the top surface of the camshaft baffle. If the before test rating is less than ten on the CRC varnish rating scale (Manual 14), polish the camshaft baffle with No. 0 fine steel wool to achieve a dull finish. Rinse with aliphatic naphtha (7.7.1) and allow to air-dry before use.

7.6.5 *Oil Pan*—Submerge the oil pan in agitated organic solvent (see 7.7.2) until clean (approximately 1 h). Rinse the part thoroughly with hot water (> 60°C). Rinse the oil pan with aliphatic naphtha (7.7.1) and allow to air-dry. Inspect the appearance of the nickel plating on the internal surface of the pan. If the before test rating is less than ten on the CRC varnish rating scale (Manual 14), polish lightly with No. 0 fine steel wool to achieve a dull finish. Rinse with aliphatic naphtha (7.7.1) and allow to air-dry before use. Replace the pan when the finish becomes unserviceable (7.4.5). Ensure that baffle attachments are in good condition.

7.6.6 *Oil Pan Baffle*—Submerge the oil pan baffle in agitated organic solvent (see 7.7.2) until clean (approximately 1 h). Rinse the part thoroughly with hot water (> 60°C). Rinse the oil pan baffle with aliphatic naphtha (7.7.1) and allow to air-dry. Inspect the appearance of the nickel plating on baffle. If the before test rating is less than ten on the CRC varnish rating scale (Manual 14), polish the oil pan baffle with No. 0 fine steel wool to achieve a dull finish. Rinse with aliphatic naphtha (7.7.1) and allow to air-dry before use. Replate the oil pan baffle when the finish becomes unserviceable (7.4.5).

7.6.6.1 Have the oil pan and oil pan baffles replated by the supplier listed in Annex A9.2

7.6.7 *PCV Valve*—Measure and record the flow rates of the PCV valve with the calibrated flow device described in 7.5.3 and Fig. A3.10. Measure the flow rate at 25 and 60 kPa vacuum. Because of the hysteresis in the PCV valve spring, make the vacuum adjustments in one direction only. Measure the flow rate twice and average the readings. Reject any PCV valve that does not exhibit an average flow rate of 90 to 140 L/min at 25 kPa and 30 to 50 L/min at 60 kPa.

7.6.8 *Water Pump Drive System*—Use only the pulleys provided in the Sequence VG test stand set-up kit (see Annex A5), crankshaft, water pump, grooved idler and tensioner, and a 956 mm (37 5/8 in.) long five or six groove belt to ensure that the water pump rotates at the proper speed and direction.

7.6.9 *Engine Coolant Temperature Sensor*—Modify engine coolant temperature sensor by attaching a relay and a 13K Ω resistor between the ECT sensor and the EEC as shown in Fig. A3.14.

7.6.10 *Front Cover*—Modify front cover to facilitate installation of tensioner, idler, and water pump drive belt. Since the

¹⁴ Available from Coordinating Research Council, Inc., 219 Perimeter Ctr. Pkwy, Atlanta, GA 30346.

belt is routed differently from the stock location some bolt bosses may need to be altered to clear the shorter belt and the tensioner. These bolt bosses are used to attach the front end accessory drive components that are not used for this test.

7.6.11 *Oil Separators*—Clean with aliphatic naphtha (7.7.1) and air-dry.

7.6.12 *Timing Chain Cover*—Submerge the timing chain cover in agitated organic solvent (see 7.7.2) until clean (approximately 1 h). Rinse the part thoroughly with hot water (> 60°C). Rinse the timing chain cover with aliphatic naphtha (7.7.1) and allow to air-dry.

7.7 *Solvents and Cleaners Required*—No substitutions for the following are allowed: **Warning**—Use adequate safety provisions with all solvents and cleaners.

7.7.1 *Aliphatic Naphtha*, Stoddard solvent¹⁵ or equivalent is satisfactory.

7.7.2 *Organic Solvent*, Penmul L460.¹⁶

7.7.3 *Dearsol 134 Acidic Cleaner*¹⁷ with Inhibitor, RAC cooling jacket internal cleaner.

7.7.4 *Cooling System Cleaner*, Dupont or equivalent, for cleaning cooling system components external to the engine.

7.8 *Assembling the Test Engine-Preparations*—Use the kit parts as received from the supplier. Complete any assembly instructions not detailed as follows in accordance with the instructions in the service manual. Measure pistons and bores to determine proper compression ring gaps. Procedures listed below that pertain to the pistons and rings may need to be performed if the engine is disassembled to change piston ring gaps (12.4.1).

7.8.1 *Parts Selection*—Instructions concerning the use of new or used parts are detailed in 7.1.1, 7.2, and 7.3.

7.8.2 *Sealing Compounds*—Use a silicon-based sealer as needed between the rear seal housing-cylinder block, the cylinder block-cylinder head-front cover interfaces, cylinder head-front cover-rocker cover interfaces, and cylinder block-front cover-oil pan interfaces.

7.8.2.1 Use silicon-based sealer sparingly since it can elevate the indicated silicon content of the used oil.

NOTE 1—Non-silicon liquid or tape thread sealers can be used on bolts and plugs.

7.8.3 *Gaskets and Seals*—Install new gaskets and seals during engine assembly.

7.8.4 *Pistons*—Pistons are select fitted during engine assembly. Ensure that pistons are numbered with the respective cylinder bores when removed from the block to assure proper reassembly of the engine.

7.8.5 *Piston Rings*:

7.8.5.1 *Ring Gap Adjustment*:

(1) Cut the top and second compression ring gaps as required to obtain the specified blowby flow rate, using the Sanford

Piston Ring Grinder.¹⁸ Record the ring side clearance(s) and new ring gap(s) on any ring(s) adjusted. Enter the new dimension(s) on the Supplemental Operational Data sheets. Typical forms for recording these dimensions are shown in Appendix X1. Ensure that the required ring gap delta and ring side clearance are attained (Table 1). Replace rings if smaller ring gaps are required. Measure the rings for cylinders 1 and 8 in the master bore. These measurements are required to determine the ring gap increase.

(2) Using the master bore, measure the ring gaps for the top rings in cylinders 1 and 8 prior to the start of the test.

7.8.5.2 *Piston Ring Cutting Procedure*:

(1) With the block in a free state, position the ring in the cylinder bore with the ring positioning tool (see Fig. A3.9) and measure the ring gap.

(2) Cut the ring to the required gap using the ring cutting burr¹⁹ rotated at a rated speed of 3450 r/min. Remove equal amounts from both sides of the gap. Make final cuts on the down stroke only. The ring is cut with a maximum increment of 0.125 mm until the desired ring gap is achieved.

(3) After the rings are cut remove the ring from the cutting tool, debur using a Sunnen soft stone²⁰ and wipe with a dry towel.

(4) Measure the gap with the ring in its respective bore positioned with the ring positioner.

(5) Repeat Steps (2) through (4) until the desired ring gap is achieved, then wash the ring with aliphatic naphtha (7.7.1) and wipe clean with a dry towel.

(6) Weigh the ring and record.

7.8.5.3 *Installation*:

(1) Install the oil control rings and the compression rings on the pistons with the gaps located over the piston pin. Position the gaps at approximately 180° intervals, with the top compression ring gap toward the rear. Install the rings using a ring spreader tool, keeping the rings' surfaces parallel to the ring groove in the piston.

(2) If any rings require replacement, then measure and record the new ring gap(s) and ring side clearance(s). Calculate ring side clearance by determining the difference between the ring groove width and the associated ring width.

7.8.6 *Cylinder Bore Measurements*—Measure the cylinder 1 and 8 cylinder bores with the bearing caps in place. Clean the bores with a dry rag. The bores shall be clean and dry when they are measured. Use a bore gage micrometer to determine the diameter of cylinder 1 and 8 at the top, middle and bottom of the second ring travel in the transverse direction.

7.9 *Assembling the Test Engine-Installations*—Assemble the engine according to the instructions in the service manual unless specified herein.

¹⁸ Available form Sanford Mfg. Co., 300 Cox St., P.O. Box 318, Roselle, NJ 07203.

¹⁹ 3/16 in. carbide ring cutting burr, No. 74010020, made by M. A. Ford.

²⁰ Sunnen soft stone, No. JHU-820.

TABLE 1 Required Piston and Piston Ring Dimensions

Ring side clearance, avg	0.0508–0.1016 mm (0.0020–0.0040 in.)
Ring gap delta	0.045–0.055 mm (0.0018–0.0022 in.)

¹⁵ Stoddard Solvent is a product of UNOCAL Chemicals Division, 7010 Mykawa St., Houston, TX 77033.

¹⁶ Penmul L460 is a product of Penetone Corp., P.O. Box 22006, Los Angeles, CA 90022.

¹⁷ Dearsol 134 Acidic Cleaner is a product of Dearborn Div., subsidiary of W. R. Grace and Co., 300 Genesee St., Lake Zurich, IL 60047.

7.9.1 *Intake Manifold*—Block the coolant bypass port in the intake manifold at the thermostat housing (7.6.2.1).

7.9.2 *Piston and Connecting Rod Assembly*—Pistons are select fitted at the factory and shall be installed into the same bores from which they were removed.

7.9.3 *Oil System Components*—All oil system components in the engine are production configuration with the exception of the oil pan which contains removable baffles.

7.9.4 *Cylinder Head*—Prior to the installation of the cylinder heads, clock the crankshaft keyway at 270° of crankshaft angle (45° BTDC for piston No. 1). Install the cylinder head on the cylinder block. Oil the head bolt threads lightly with EF-411²¹ oil, and torque the head bolts according to the sequence described in the service manual. Do not use any sealing or anti-seizure compounds on the cylinder head gasket.

7.9.5 *Camshaft and Related Components*—The camshafts used in this test are for a Ford 4.6L truck engine application and will be different than what is shown in the service manual. The camshaft sprocket is an integral part of the camshaft. Install the camshaft in the same manner as described in the service manual with the exception of the sprocket installation.

7.9.5.1 Prior to the timing chain installation, clock the crankshaft keyway at 315° of crankshaft angle (TDC of piston No. 1) as described in the service manual.¹⁵ Rotate the crankshaft clockwise only, when viewed from the front.

7.9.5.2 When viewed from the rear, maintain the camshaft D-slot shall at a 90° clocked position relative to the cam cover rail.

7.9.5.3 When installing the timing chains ensure that the timing marks (mentioned above) remain aligned. Install L.H. crankshaft sprocket with timing chain on the crankshaft. Drape the L.H. timing chain over camshaft sprocket. The timing chain shall hang below the tensioner dowel.

7.9.5.4 Repeat the procedure in 7.9.5.3 for the right hand timing chain. After installation, the timing chain shall hang between the chain guide and the tensioner dowel.

NOTE 2—There should be a minimum of chain slack on the tension side between the two sprockets.

7.9.6 *Rocker Arm Cover and Baffle*—Fasten the camshaft baffle to the rocker cover. Cut off the tabs from the rocker cover gasket and install it in the gasket groove on cover rail. Install rocker arm cover on the cylinder head and confirm that the baffle does not contact any valve train components. Using new rubber washers on the bolts, torque the bolts to 8 to 12 N·m (the rubber washers are not reusable). The two rocker covers are different, ensure that the correct cover is installed on the correct head (Figs. A3.4 and A3.5).

7.9.7 *Oil Pan, Baffles, and Insulation*—Install front and rear oil pan baffles to the oil pan as shown in Fig. A3.7. Install front baffle first. Install the oil pan according to the procedure in the service manual. Install the oil pan insulation over the oil pan.

7.9.8 *Water Pump, Water Pump Drive*—Install the water pump and pulley, the crankshaft pulley, and the idler and tensioner according to the service manual. These are the only components needed to drive the water pump. All other produc-

tion front end accessory drive components can be discarded. Pull back tensioner and install water pump drive belt as shown in Fig. 3. Ensure that there is a minimum contact angle of 20° between the drive belt and the water pump pulley.

7.10 *Engine Installation on the Test Stand*—Functions that are to be performed in a specific manner or at a specific time in the assembly process are noted.

7.10.1 *Mounting the Engine on the Test Stand*—Mount the engine on the test stand so that the flywheel friction face is 4.0 ± 0.5° from vertical, with the front of the engine higher than the rear. The engine mounting system should be designed to minimize engine vibration at 700 to 2900 r/min. Couple the engine directly to the dynamometer through a driveshaft. The engine cannot be used to drive any external engine accessory other than the water pump.

7.10.2 *Exhaust System and Gas Sampling Fittings:*

7.10.2.1 The required exhaust manifold, a typical exhaust system, and fittings for exhaust gas sampling are illustrated in Figs. A3.15 and A3.16. Exhaust components should be constructed of either solid or bellows pipe/tubing. Other type flexible pipe is not acceptable.

7.10.2.2 The exhaust gas sample probes can be used until they become unserviceable. If the existing probes are not cracked, brittle, or deformed, clean the outer surface and clear all port holes. Check the probes for possible internal obstruction and reinstall the probes in the exhaust pipe. Stainless steel probes are generally serviceable for several tests; mild steel probes tend to become brittle after one test. (**Warning**—Exhaust gas is noxious.) (**Warning**—Any leaks in the connections to the sample probe will result in erroneous O₂ readings and incorrect air-fuel ratio adjustment.)

7.10.3 *Oil Dipstick and Tube*—Install modified oil dipstick and dipstick tube, described in 7.4.4, in the engine block at the production location and attachment points.

NOTE 3—The intake manifold, the rocker arm covers, and the exhaust manifolds can be installed after the engine is installed on the test stand.

7.10.4 *Fuel management System:*

7.10.4.1 *Fuel Rail Injectors:*

(1) The fuel injectors can be used for multiple tests providing they meet the flow and other requirements delineated in Fig.

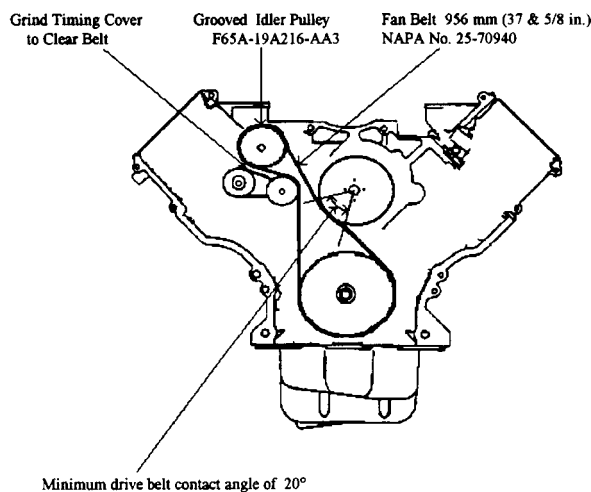

FIG. 3 4.6L Water Pump Drive Arrangement

²¹ Mobil EF-411 oil is a product of Mobile Oil Corp., 3225 Gallows, Fairfax, VA 22037.

A13. Fuel injectors that have caused misfires in previous tests should be cleaned before reuse. Commercial injector cleaning fluids and flow benches are available from various manufacturers. Do not use injector cleaning fluids while operating the engine.

(2) Inspect the O-rings to ensure they are in good condition and will not allow fuel leaks. Install the fuel injectors into the fuel rail and into the intake manifold.

7.10.4.2 *Electronic Engine Control (EEC) System*—The fuel injector operation, cylinder firing, pulse width, ignition timing, and so forth, are controlled by the specified EEC. The EEC module is available from the supplier listed in Annex A9.2

(1) The EEC power shall come from a battery (13.5 ± 1.5 V to red wire) and not a power supply which may interrupt/interfere with proper EEC operation. Connect the EEC battery to the engine wire harness with an appropriate gage wire of the shortest practical length so as to maintain 12 to 15 V DC on the STAR tester and minimize EEC electrical noise problems. Ground the EEC ground wire to the engine. From the same ground point, run a minimum two gage wire back to the battery negative to prevent interruption/interference of the EEC operation.

7.10.5 *Spark Plugs*—Install new Motorcraft AWSF-32PP spark plugs that have been gapped to 1.37 mm (0.054 in.) Torque the spark plugs to 9-12 N·m. Install the spark plug wiring harness. Do not use anti-seize compounds on spark plug threads.

NOTE 4—The components used in the ignition system do not require modification.

7.10.6 *Crankcase Ventilation System*—The crankcase ventilation system is a closed system allowing blowby to be vented from the crankcase and drawn into the intake manifold. A description of the system operation is shown in Fig. 4. Install PCV system components and hoses as shown in Fig. A3.17.

7.10.6.1 *Oil Separator and PCV Valve*—Use two clean oil separators and a new PCV valve listed in the parts list Annex A5. Oil separators can be reused as long as they remain serviceable.

7.10.6.2 *Three-Way Valve*—Install a clean three-way valve and attach the PCV valve hose. Install the remaining PCV valve hose between the three-way valve and the intake manifold (see Fig. A3.17). Do not allow the hose to flatten at the bend after installation.

7.10.7 *Intake Air Components*—Install the throttle body, air cleaner assembly, and new air cleaner. Modify the air cleaner assembly to accept fittings for inlet air temperature thermocouple, pressure tap and fresh air, as shown in Fig. A3.1.

7.10.8 *External Hose Replacement*—Inspect all external hoses used on the test stand and replace any hoses that have become unserviceable. Check for internal wall separations that could cause flow restrictions. Check all connections to ensure security.

7.10.9 *Wiring Harness*—There are two wiring harnesses used on the test stand, a dynamometer harness and an engine harness. Obtain the dynamometer wiring harness from the supplier listed in Annex A9.2. The engine harness is listed in Annex A5.

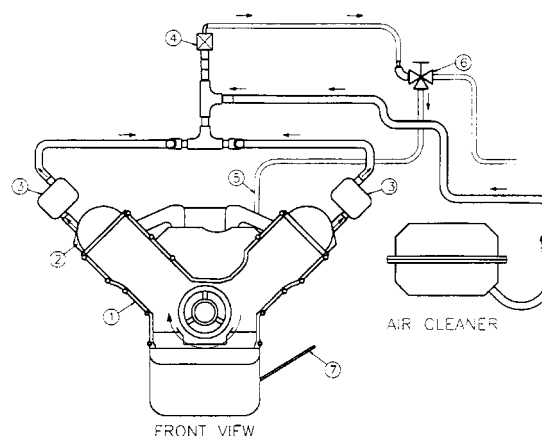

- NOTE—Legend
- (1) Blowby flows through 6 oil drain back passages in cylinder block and head and through the front cover.
 - (2) Cam baffle shields cover from oil.
 - (3) Oil separator prevents loss of oil into PCV valve.
 - (4) PCV valve flows approximately 120 L/min (4.2 cfm). Blowby rate is 60-70 L/min (2.12-2.47 cfm).
 - (5) Air vent provides balance of flow by PCV valve. When excessive plugging of the PCV valve occurs excess blowby is vented to the engine air intake.
 - (6) Three-way ball valve routes blowby to the intake manifold and provides a connection point for blowby measurement apparatus.
 - (7) Dipstick tube is location for crankcase pressure measurement.

FIG. 4 Functional Description of Closed Crankcase Ventilation System

8. Engine Fluids-Supply/Discharge Systems

8.1 *Intake Air*—Condition the intake air to $30 \pm 0.5^\circ\text{C}$, 11.4 ± 0.8 g/kg humidity, and pressurized to 0.05 ± 0.02 kPa.

8.1.1 *Capacity*—The supply system shall be capable of delivering 110 L/s of conditioned air, while maintaining the intake/air parameters detailed in Table 2. The test stand intake air duct system is shown in Fig. 2.

8.1.2 *Dew Point*—The dew point may be measured in the main system duct or at the test stand. If the dew point is

TABLE 2 Sequence VG Operating Specification

Condition	Stage I	Stage II	Stage III
Duration, min	120	75	45
Engine speed, r/min	1200 ± 5	2900 ± 5	700 ± 15
Engine power, kW	record	record	1.30 ± 0.2
Manifold abs press, kPa (abs)	69 ± 0.2	66 ± 0.2	record
Engine oil in, °C	68 ± 0.5	100 ± 0.5	45 ± 1
Engine coolant out, °C	57 ± 0.5	85 ± 0.5	45 ± 1
Engine coolant flow, L/min	48 ± 2	record	record
Engine coolant pressure, kPa (gage)	70 ± 10	70 ± 10	70 ± 10
RAC coolant in, °C	29 ± 0.5	85 ± 0.5	29 ± 1
Rocker cover flow, L/min	15 ± 1	15 ± 1	15 ± 1
Intake, air, °C	30 ± 0.5	30 ± 0.5	30 ± 0.5
Intake air press, kPa (gage)	0.05 ± 0.02	0.05 ± 0.02	0.05 ± 0.02
Exhaust gas analysis			
O ₂ , volume %	1.0 max	1.0 max	3.0 max
CO, volume %	1.0 max	2.0 max	8.5 ± 1.5
CO ₂ , volume %	13.5–15.5	13.5–15.5	record
NO _x , ppm	—	record ^A	—
Blowby flow rate, avg, L/min	record	60-70	—
Intake air humidity, g/kg	11.4 ± 0.8	11.4 ± 0.8	11.4 ± 0.8
Exhaust back pressure, kPa abs	104 ± 2	107 ± 2	record
Fuel flow, kg/min	record	record	record

^A The average NO_x level during a test should be within 600 ppm of the cumulative calibration test average NO_x (see 14.2).

measured in the main system duct, verify the dew point periodically at the test stand. Maintain the duct surface temperature above the dew point temperature at all points downstream of the humidity measurement point to prevent condensation and loss of humidity level.

8.2 Fuel and Fuel System:

8.2.1 System Description—A schematic diagram of a typical fuel supply system is shown in Fig. 1. Supply an excess volume of fuel to the fuel rail at all times. Introduce make-up fuel (fuel used by the engine) into the loop from an external source. Mix the make-up fuel with fuel that is returned from the fuel rail (fuel not used by the engine). Pump the fuel through a mixing chamber, or small heat exchanger, which is used to mix the two streams and provide fuel of consistent temperature to the engine. Deliver the fuel to a high-pressure pump (Ford P/N E7TF-9C407 or E7TC-9C407), that boosts the pressure and supplies the fuel to the fuel rail.

8.2.2 Controls—Maintain the fuel temperature to the fuel rail below 50°C. To ensure good atomization of the fuel, maintain the fuel pressure to the fuel rail above 185 kPa. In addition, the fuel pressure should be constant at all steady-state conditions to ensure good speed, power, and air-fuel ratio control.

8.2.3 Fuel Volume Required—Approximately 3300L of sequence VG unleaded gasoline are required for each test.

8.2.4 Fuel Batch Approval Process—Obtain fuel from the supplier listed in Appendix X2.1.5. Each new batch of fuel is approved by the following process:

8.2.4.1 Before initial blending, typical samples of the fuel blend components are analyzed, and the data are compared with predetermined physical specifications. A small amount of fuel mixture is then blended, analyzed, and compared to predetermined specifications. The ASTM Testing Monitoring Center (TMC) confirms the acceptability of the fuel mixture analytical data and authorizes blending of the entire batch for engine testing. After the entire batch is blended, the TMC confirms the acceptability of the analytical data of the entire fuel batch, and authorizes the engine test fuel approval program.

8.2.4.2 A sample of the fuel is shipped to two designated independent laboratories. A designed program involving more than one calibration test is completed using reference oils selected by the TMC. (The Sequence V Reference Oils and Fuels Sub Panel, ASTM D.02.B0.01.05, is involved in the design of the program.) The TMC reviews the test results and if acceptable, authorizes the fuel supplier to notify potential purchasers of the approval status of the fuel batch.

8.2.5 Fuel Batch Analysis—Upon receipt from the supplier, it is the responsibility of the laboratory to analyze each fuel shipment to determine the value of the parameters shown in Table 3 (except sulfur, oxidation stability, and distillation). Compare the results to the values obtained by the supplier on that particular batch. The results should be within the specification band shown in Table 3 beside each parameter. This provides a method to determine if the fuel batch is contaminated or has aged prematurely. If any results fall outside the tolerances shown in Table 3, the laboratory should contact the TMC for help in resolving the problem. One potential method

TABLE 3 VG Fuel Analysis

NOTE 1—Appearance, water, lead, and oxidation stability are analyzed on an absolute basis.

Parameter	Specification Band
API gravity ^A	58.7–61.2
RVP ^B	60.7–63.4 kPa
Total sulfur ^C	0.01–0.04 wt % max
Existent gum ^D	5mg/100 mL, max
Distillation ^E	
IBP	22.2–35.0°C
10 %	48.9–57.2°C
50 %	98.9–115.2°C
90 %	162.8–176.7°C
EP	196.1–212.8°C
Appearance	clear and bright
Water ^F	0.01 vol %, max
Lead ^G	10 mg/L max
Oxidation stability ^H	1440 minutes, min

^A In accordance with Test Method D 1298 or D 287.

^B In accordance with Test Method D 323 or Automatic Reid Vapor Pressure.

^C In accordance with Test Method D 4294, D 1266, or D 2622.

^D In accordance with Test Method D 381.

^E In accordance with Method D 86.

^F In accordance with Test Method D 6304.

^G In accordance with Test Method D 3237 or D 5059.

^H In accordance with Test Method D 525.

for resolving the problem is to obtain an analysis at the fuel supplier's laboratory of the *as received* fuel sample.

8.2.6 Laboratory Storage Tank Fuel Analysis—Analyze the contents of each fuel storage tank that contains fuel used for calibrated Sequence VG tests bi-monthly. Analyze fuel in run tanks, those with a direct feed line to test engines, every month. Laboratories should take composite samples using Table 1 in Practice D 4057, as a guideline. The fuel supplier shall have the capability to analyze the fuel samples using the test methods specified in Table 3 and this section. The fuel supplier shall provide an adequate supply of fuel sample containers with packaging and pre-addressed return labels to each Sequence VG laboratory. Upon receipt of all fuel samples required in 8.2.6 from the laboratories, the fuel supplier shall perform the following analyses, report the results to the submitting laboratory, and tabulate the results in a database.

Reid vapor pressure (Test Method D 323)	Washed gums (Test Method D 381)
API gravity (Test Method D 287 or D 1298)	Unwashed gums (Test Method D 381)
Distillation (Test Method D 86)	Benzene (Test Method D 3606)
Lead (Test Method D 3237 or D 5059)	

8.2.6.1 When results from the physical and chemical tests listed above appear to differ significantly from the expected results, analyze a second sample, or conduct the following tests, or do both:

Hydrocarbon speciation (Test Method D 2789)
Oxidation stability (Test Method D 525)
Potential gums (Test Method D 873)

8.2.6.2 The fuel supplier shall also issue a bi-monthly analysis of the fuel from the main storage tank, which should represent normal aging. The analysis shall include the parameters in Table 3.

8.2.6.3 Forward the results of the analyses performed in 8.2.6 and 8.2.6.1 to the TMC for inclusion in the appropriate data base.

8.2.7 Fuel Batch Shipment and Storage—Ship the fuel in

containers with the minimum allowable venting as dictated by all safety and environmental regulations, especially when shipment times are anticipated to be longer than one week. Store the fuel following all applicable safety and environmental regulations.

8.3 Engine Oil and Engine Oil System:

8.3.1 Test Oil Description:

8.3.1.1 The test oil sample shall be uncontaminated and representative of the lubricant formulation being evaluated.

8.3.1.2 A minimum of 7.5 L of new oil is required to complete the test. A 20L sample of new oil is normally provided to allow for inadvertent losses.

8.3.2 System Description:

8.3.2.1 Configure the oil system as shown in Fig. A3.8 to minimize stand-to-stand variations that could influence test severity. Measure engine oil pressure at the points shown in Fig. 5. The oil flow rate and external pressure drop are controlled by specifying the volume, plumbing configuration, and orientation of the heat exchanger. The oil flow out of the vertically mounted heat exchanger shall be level with the oil-in thermocouple. The lengths of the lines are not specified although the line diameters are indicated in Fig. A3.8. The line

length and diameter have a large influence on the volume of the external system. The internal volume of the entire external system shall be 540 ± 30 mL.

8.3.2.2 Use oil filter adapter OHT6A-0007-1 (Appendix X2.1.11), oil filter OHT6A-012-2 (Appendix X2.1.11). Be sure all hoses and fittings on the oil heat exchanger are properly connected and secure. *The external oil system components shall not be brass, copper or galvanized, as these metals may influence used oil analysis.*

8.3.3 Heat Exchanger—The heat exchanger has been chosen to minimize the volume of the external system. The heat exchanger has adequate but not excessive capacity to control the oil temperature. The system requires a high level of maintenance to provide adequate cooling, especially when process water temperature is high. An effective, well-maintained process water control system is necessary to achieve the specified oil temperatures. Use vertically mounted ITT heat exchanger P/N 5-160-02-008-002 (Appendix X2.1.9). Configure the system to allow the process water to flow through the vertical tubes and the oil through the shell. This orientation will facilitate cleaning of the tubes.

8.3.4 System Cleaning:

8.3.4.1 Clean the external oil cooling system thoroughly before each test. An acceptable technique for cleaning the oil heat exchanger is detailed in Annex A6. Flush and rinse the external lines before each test. The specific technique used (removed from or flushed on the stand, and so forth) is left to the discretion of the laboratory.

8.3.4.2 Regardless of the flushing technique employed, use an organic solvent (see 7.7.3) for the final flushing followed by separate rinses with hot ($> 60^{\circ}\text{C}$) water and aliphatic naphtha (7.7.1) before air-drying the components. (**Warning**—Incomplete cleaning of the external oil system may allow debris to dislodge and circulate throughout the engine during subsequent tests. Incomplete cleaning may also cause oil temperature control problems and contaminate subsequent test oils.)

8.3.5 Control Specifications—The operating conditions are specified in Table 2. Additional information concerning the oil pressure, is found in 12.5.7. Cyclic ramping specifications are detailed in Table 4.

8.4 Coolants:

8.4.1 Description—The engine coolant is equal parts of demineralized (less than 0.34 g/kg) or distilled water and a fully formulated ethylene glycol based automotive antifreeze to protect against corrosion of all system components. The RAC coolant is a solution of demineralized (less than 0.34 g/kg) or distilled water and an additive treatment of 475 mL of Pencool 2000²² per 15 L of water.

8.4.2 General System Description—The following guidelines are common to both the engine and RAC coolant systems:

8.4.2.1 A transparent section is required to permit visual inspection of the coolant. Provide air bleeds to allow removal of entrained air. Provide a drain at the low point of the system to allow complete draining of the system.

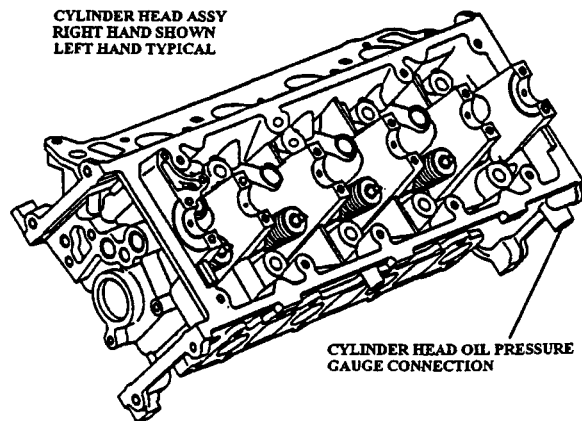
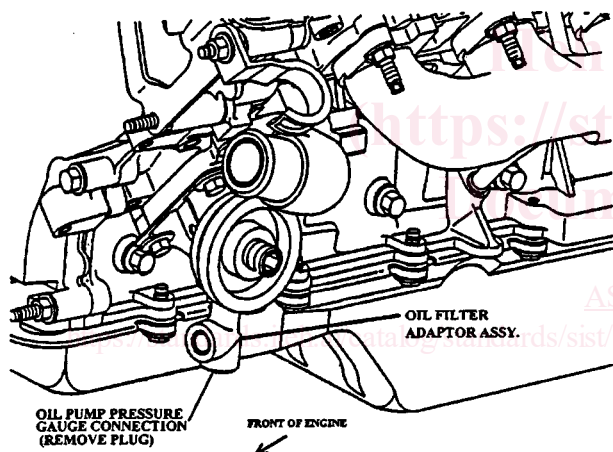

FIG. 5 Oil Pressure Gage Connections

²² Pencool 2000 coolant is a product of Penray Cos., Inc., 1801 Estes Ave., Elk Grove, IL 60007.

TABLE 4 Test Ramping Requirements^A

Stage III to I	
Engine speed	1195 r/min within 5 to 20 s
Manifold absolute pressure	68.8 kPa within 20 to 80 s
Oil inlet temperature	67.5°C within 8 ± 2 min
Coolant outlet temperature	56.5°C within 6 ± 2 min
Rocker arm cover inlet temperature	29°C within 17 min
Stage I to II	
Engine speed	2895 r/min within 30 to 90 s
Manifold absolute pressure	66 ± .2 kPa within 60 to 150 s
Oil inlet temperature	99.5°C within 7 ± 2 min
Coolant outlet temperature	84.5°C within 7 ± 2 min
Rocker arm cover inlet temperature	84.5°C within 17 ± 2 min
Stage II to III	
Engine speed	715 r/min within 5 to 20 s
Engine power	< 3kW at 5 to 20 s
Oil inlet temperature	46°C within 15 ± 2 min
Coolant outlet temperature	46°C within 9 ± 2 min
Rocker arm cover inlet temperature	30°C within 10 ± 2 min

^A *Test Ramping Requirements Information*—Switch ECT to the fixed resistor at the onset of the Stage II to Stage III ramp. At the onset of Stage III to Stage I ramp, switch from the fixed resistor to the ECT.

8.4.2.2 An effective, well-maintained process water control system is necessary to achieve the specified coolant temperatures.

8.4.2.3 The system shall allow precise calibration of the flowmeters, after installation in the test stand. Avoid turbulence near the measurement meters, and the flowmeters used for calibration.

8.4.3 Engine Coolant System Description:

8.4.3.1 Configure the engine cooling system according to the schematic diagram shown in Fig. A3.18. The engine coolant system volume shall be 24 ± 2 L. This volume includes all equipment, plumbing, and the engine excluding the coolant reservoir and plumbing connecting the coolant reservoir with the main system (see Fig. A3.18). The coolant reservoir volume shall be 9.0 ± 2 L. The thermostat housing is modified to accept the coolant outlet temperature thermocouple (9.1.3). *Do not install the thermostat.* Block coolant bypass port in intake manifold (7.6.2.1). Inspect the water pump drive belt for defects before installation.

8.4.3.2 A radiator cap is used to limit system pressure to 105 kPa. Pressurize the coolant system to 70 ± 10 kPa at the top of the coolant reservoir (Fig. A3.18).

8.4.3.3 The engine coolant flow rate and outlet temperature are controlled in accordance with the specifications listed in Table 2. Information concerning the cooling flow rate measurement device is detailed in 9.3.2. Cyclic ramping specifications are detailed in Table 4. The coolant flow rate is measured with a venturi flowmeter (Appendix X2.1.6) and controlled with an in-line flow control valve.

8.4.3.4 Modify the engine coolant temperature sensor to deliver the correct signal to the EEC during the start of Stage III. Attach a relay and resistor as shown in Fig. A3.14 between the ECT sensor and EEC module.

8.4.3.5 As a minimum, inspect and clean the engine coolant system components, external to the engine, prior to running each reference calibration test. A specific flushing technique is not specified. However, the technique should employ a commercial descaling cleaner (7.7.3).

8.4.4 RAC Coolant System Description:

8.4.4.1 Inspect and clean the complete RAC control system prior to running each reference oil calibration test. A specific flushing technique is not specified. However, the technique should employ a commercial descaling cleaner (7.7.3).

8.4.4.2 Schematic diagrams of the RAC coolant control systems are shown in Fig. 6. Derive heat for the control system from an external source, such as hot water, steam, or an electric immersion heater.

8.4.4.3 Control the RAC coolant flow rate and inlet temperature in accordance with the specifications listed in Table 2. The coolant pressure is not specified, but design the system to minimize the pressure on the RAC and prevent distortion of the jacket. (**Warning**—Maintain the system pressure below 70 kPa (10 psig) to prevent distortion of the RAC jacket.)

8.5 Cyclic ramping specifications are detailed in Table 4.

9. Measurement Instrumentation

9.1 Temperatures:

9.1.1 Equipment:

9.1.1.1 Temperature measurement locations for the six required temperatures are specified. Use thermocouples that are calibratable to 0.5°C. Use only OEM temperature sensors for EEC inputs.

9.1.1.2 All thermocouples, except the intake-air thermocouple, shall be premium and sheathed. The intake-air thermocouple may be an open-tip type. Thermocouples shall be either 1/8 in. diameter by 4 in. long or 3 mm diameter by 100 mm long. Thermocouples, wires, and extension wires should be matched to perform in accordance with the special limits of error as defined in ANSI MC96.1.

9.1.2 *Engine Coolant Inlet*—Install the sensor in the outlet perpendicular to the run of the tee fitting. Install sensor with the tip in the center of the stream of flow, directly opposite of the perpendicular outlet. Locate the tee fitting 300 to 400 mm upstream from the water pump inlet (see Fig. A3.18).

9.1.3 *Engine Coolant Outlet*—Install the temperature sensor in the modified thermostat housing. Locate the tip of the temperature sensor in the center of the stream of flow and is located in the thermostat housing *neck* within 8 cm of the housing outlet.

9.1.4 *Engine Oil Inlet*—Install the tip of the sensor at the center of the flow stream through the external oil filter adapter (see Fig. A3.8). Tip of sensor shall be even with the machined surface of the oil filter adapter.

9.1.5 *Engine Oil Outlet*—Install the tip of the sensor at the center of the cross fitting attached to the bottom of the heat exchanger (see Fig. A3.8). Locate the sensor along the same axis, but opposite, the outlet port connected to the heat exchanger. The tip shall be within 2 mm of the center distance between the external most surfaces of the outlets along the axes.

9.1.6 *Intake Air*—Install the tip of the thermocouple mid-stream in the air cleaner (see Annex A3.1). Insertion depth shall be 55 ± 2 mm.

9.1.7 *RAC Coolant Inlet*—Install the tip of the thermocouple at the center of the cross fitting before the inlets of the RAC's (see Fig. 6, item 8). Locate the sensor along the same axis, but opposite the inlet port of the incoming fluid. The tip

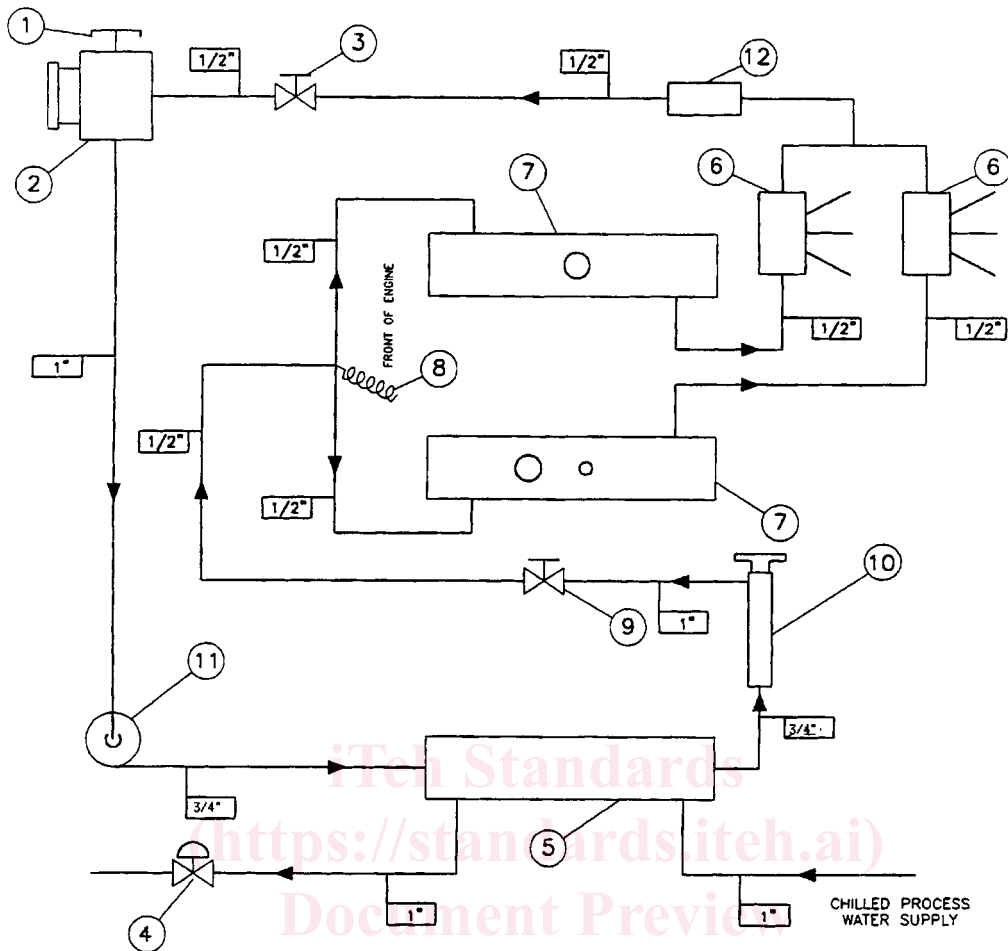

NOTE—Legend

- | | |
|------|---|
| (1) | Vented reservoir cap |
| (2) | Coolant reservoir (fabricated) |
| (3) | Pressure control valve (optional) |
| (4) | Chilled process water control valve |
| (5) | Stage I and III heat exchanger |
| (6) | F and P Co. flowrator tube, FF-1-35-G-10/448D053U06 |
| (7) | Rocker arm covers |
| (8) | Inlet temperature sensor |
| (9) | Flow control valve |
| (10) | External heat source |
| (11) | Electric coolant pump DAYTON 6K581A |
| (12) | ABB Kent-Taylor flow element, 1330LZ08000-8375A |

FIG. 6 Typical Rocker Arm Cover Heating and Cooling System

shall be within 2 mm of the center distance between the external most surfaces of the outlets along the axes.

9.1.8 *Calibration*—Calibrate all thermocouples prior to a reference oil test. The temperature measurement system shall indicate within $\pm 0.5^{\circ}\text{C}$ of the laboratory calibration standard. The calibration standard shall be traceable to NIST.

9.2 *Pressures:*

9.2.1 *Equipment*—Pressure measurement for each of the eight required parameters is detailed in the following sections. This allows reasonable opportunity for adaptation of existing test stand instrumentation. However, the accuracy and resolution of the pressure measurement sensors and the complete pressure measurement system shall follow the guidelines

detailed in ASTM Research Report RR:D-1218.²³ Replace pressure sensors that are part of the EEC system with only Ford specified equipment.

NOTE 5—Tubing between the pressure tap locations and the final pressure sensors should incorporate condensate traps, as indicated by good engineering practice. This is particularly important in applications where low air pressures are transmitted by means of lines which pass through low-lying trenches between the test stand and the instrument console.

9.2.2 *Intake Manifold Absolute*—Measure the manifold absolute pressure at the port on the top side of the throttle body spacer (see Figs. A3.2 and A3.28).

²³ Available from ASTM International Headquarters, 100 Barr Harbor Dr., West Conshohocken, Pa. 19428-2959.

9.2.3 *Engine Oil*—Measure oil pump pressure at the bottom port of the oil filter adapter housing on the engine block (see Fig. 5 and Figs. A3.25 and A3.26). Take cylinder head oil pressure measurements on the sides of the cylinder heads on the rear of the left cylinder head and front of the right cylinder head (see Fig. 5 and Figs. A3.24, and A3.27). Use individually dedicated pressure sensors.

9.2.4 *Engine Coolant Pressure*—Measure engine coolant pressure at the top of the coolant reservoir as shown in Fig. A3.18.

9.2.5 *RAC Coolant*—RAC coolant pressure can be measured at the coolant inlet cross fitting as is done with temperature although monitoring of RAC pressure is not required. Pressure should remain adequate as long as temperature and flow are within the limits of Table 2.

9.2.6 *Fuel*—Measure the fuel pressure near the injector rail inlet as shown in Fig. 1. When utilizing a pressure gage mounted directly to the injector rail, the gage should be a damped, liquid-filled type. **Warning**—Too much weight attached to the fuel rail may cause it to leak. Any instrumentation attached to the fuel rail should be supported by something other than the fuel rail.

9.2.7 *Intake Air*—Measure the intake-air pressure in the air cleaner housing in the location shown in Fig. A3.1. Insertion depth of the probe shall be 50 ± 2 mm. If a manometer is used, install a liquid trap to prevent manometer fluid from entering the intake-air cleaner.

9.2.8 *Crankcase*—Measure the crankcase pressure at the dipstick tube. The sensor shall be capable of measuring positive and negative pressure. If a manometer is utilized, install a liquid trap to prevent manometer fluid from entering the crankcase.

9.2.9 *Exhaust Back Pressure*—Measure the exhaust back pressure with the exhaust gas sampling probe located downstream in the Y (see Fig. A3.16). A sensor capable of absolute or gage measurement corrected with barometric pressure reading is recommended. Install a condensate trap between the probe and sensor to accumulate water present in the exhaust gas.

9.2.10 *Calibration*—Calibrate all pressure measurement sensors prior to a reference oil test. The MAP pressure measurement system shall indicate within 0.1 kPa of the laboratory calibration standard. All other pressure measurement systems shall conform to the guidelines in ASTM Research Report RR:D02.1218. The calibration standard shall be traceable to NIST.

9.3 Flow Rates:

9.3.1 *Equipment*—Flow rate measurement for each of the four required parameters is detailed in the following subsections. With the exception of the engine coolant and blowby flow rates, measurement equipment is not specified for a given parameter. This allows reasonable opportunity for adaptation of existing test stand instrumentation.

9.3.2 *Engine Coolant*—Determine the engine coolant flow rate by measuring the differential pressure drop across the specified venturi flowmeter (see Fig. A3.18) Flowmeter is available from the supplier in Appendix X2.1.6. Take precautions to prevent air pockets from forming in the lines to the

pressure sensor. Transparent lines or bleed lines, or both, are beneficial in this application. Ensure that the manufacturers required straight sections of pipe are installed immediately up and down stream of the flowmeter.

9.3.3 *RAC Coolant*—Measure the total volumetric coolant flow rate through the RAC system and the individual RAC flowrates as shown in Fig. 6.

9.3.3.1 *Calibration*—Calibrate the flowmeters used in the measurement of both the engine coolant flow rate and RAC coolant flow prior to a reference oil test. Calibrate the flowmeters as installed in the system at the test stand with test fluid. Calibrate the flowmeters with a turbine flowmeter or by a volume/time method at Stage I operating conditions.

9.3.4 Blowby:

9.3.4.1 Measure the blowby flow rate using the apparatus shown in Fig. 7. The measurement system routes the blowby through an external, sharp-edged orifice and into the engine intake manifold by means of an auxiliary (*dummy*) PCV valve. Maintain crankcase pressure at 0.0 ± 25 Pa during operation of the system to minimize the potential for crankcase leakage. *Mount the dummy PCV valve and orifice plate in a vertical position.*

9.3.4.2 Determine the blowby flow rate by measuring the differential pressure drop across the sharp-edged orifice; an inclined manometer or differential pressure sensor is required for measurement of the differential pressure drop. The differential pressure drop sensor shall have a range from 0 to 1 kPa.

9.3.4.3 The sharp-edged orifice assembly is specifically designed for blowby flow rate measurement and shall be fabricated in strict compliance with the specifications that are available from the TMC. Additional information on the orifice system can be obtained from the source listed in Appendix X2.1.8 The assembly contains five orifices. The 0.375 in. orifice is generally satisfactory for the range of blowby flow rate encountered. The complete orifice assembly can also be purchased from the supplier listed in Appendix X2.1.11.

9.3.4.4 *Maintenance*—As a minimum, clean the blowby measurement apparatus weekly. Replace the o-rings with each cleaning. Exercise particular care when cleaning the orifice meter assembly. Clean the three-way valve by soaking the valve in agitated organic solvent (see 7.7.3) until clean, followed by hot ($> 60^\circ\text{C}$) water rinse and spray rinse with aliphatic naphtha. Use compressed air to force air-dry. Inspect the port passages and remove any carbonaceous deposits by scraping. If the valve is disassembled for cleaning, make sure the core is properly seated upon reassembly.

9.3.4.5 *Calibration*—Calibrate the blowby orifice meters used for laboratory measurements standards every six months. Calibrate laboratory blowby measurements standards, not used for production, yearly. The calibration standard shall be traceable to the NIST. Calibrate the temperature measuring devices in the blowby system every six months. (**Warning**—Internal leakage within the three-way valve may cause some of the blowby gas to pass directly to the intake manifold from the test PCV valve and result in erroneous blowby flow rate measurements (see Fig. 7).)

9.4 *Fuel Consumption*—Determine the fuel consumption rate by measuring the amount of make-up fuel flowing from the