



Test Methods For Intervertebral Body Fusion Devices¹

This standard is issued under the fixed designation F 2077; the number immediately following the designation indicates the year of original adoption or, in the case of revision, the year of last revision. A number in parentheses indicates the year of last reapproval. A superscript epsilon (ϵ) indicates an editorial change since the last revision or reapproval.

1. Scope

1.1 This test method covers the materials and methods for the static and dynamic testing of intervertebral body fusion device assemblies, spinal implants designed to promote arthrodesis at a given spinal motion segment.

1.2 This test method is intended to provide a basis for the mechanical comparison among past, present, and future non-biologic intervertebral body fusion device assemblies. This test method allows comparison of intervertebral body fusion device assemblies with different intended spinal locations and methods of application to the intradiscal spaces. This test method is intended to enable the user to compare intervertebral body fusion device assemblies mechanically and does not purport to provide performance standards for intervertebral body fusion device assemblies.

1.3 The test method describes static and dynamic tests by specifying load types and specific methods of applying these loads. These tests are designed to allow for the comparative evaluation of intervertebral body fusion device assemblies.

1.4 This test method does not purport to address expulsion testing of intervertebral body fusion device assemblies. However, since expulsion is a potential clinical failure mode, the user should address the implant's resistance to expulsion.

1.5 Guidelines are established for measuring displacements, determining the yield load or moment, evaluating the stiffness, and strength of the intervertebral body fusion device assemblies.

1.6 Some intervertebral body fusion device assemblies may not be testable in all test configurations.

1.7 The values stated in SI units are to be regarded as the standard with the exception of angular measurements, which may be reported in terms of either degrees or radians.

1.8 *This standard does not purport to address all of the safety concerns, if any, associated with its use. It is the responsibility of the user of this standard to establish appropriate safety and health practices and determine the applicability of regulatory limitations prior to use.*

2. Referenced Documents

2.1 ASTM Standards:

- E 4 Practices for Force Verification of Testing Machines²
- E 6 Terminology Relating to Methods of Mechanical Testing²
- E 1823 Terminology Relating to Fatigue and Fracture Testing²
- F 1582 Terminology Relating to Spinal Implants³

3. Terminology

3.1 For definition of terms refer to Terminology E 6, E 1823, and F 1582.

3.2 Definitions of Terms Specific to This Standard:

3.2.1 *coordinate system/axes, n*—Three orthogonal axes are defined by Terminology F 1582. The center of the coordinate system is located at the geometric center of the intervertebral body fusion device assembly. The XY plane is to bisect the sagittal plane angle between superior and inferior lines (surfaces) that are intended to simulate the adjacent vertebral end plates. The positive Z axis is to be directed superiorly. Force components parallel to the XY plane are shear components of loading. The compressive axial force is defined to be the component in the negative Z direction. Torsional load is defined to be the component of moment parallel to the Z axis.

3.2.2 *fatigue life, n*—The number of cycles, N , that the intervertebral body fusion device assembly can sustain at a particular load or moment before mechanical or functional failure occurs.

3.2.3 *functional failure, n*—Permanent deformation that renders the intervertebral body fusion device assembly ineffective or unable to resist load and/or maintain attachment adequately.

3.2.4 *ideal insertion location, n*—The implant location with respect to the simulated inferior and superior vertebral bodies (polyacetal or metal blocks) dictated by the type, design, and manufacturer's surgical installation instructions.

3.2.5 *intended method of application, n*—Intervertebral body fusion device assemblies may contain different types of stabilizing anchors such as threads, spikes, and knurled surfaces. Each type of anchor has an intended method of application or attachment to the spine.

3.2.6 *intended spinal location, n*—The anatomic region of the spine intended for the intervertebral body fusion device assembly. Intervertebral body fusion device assemblies may be

¹ This test method is under the jurisdiction of ASTM Committee F04 on Medical and Surgical Materials and Devices and is the direct responsibility of Subcommittee F04.25 on Spinal Devices.

Current edition approved May, 10 2001. Published June 2001. Originally published as F 2077 - 00. Last previous edition F 2077 - 00.

² *Annual Book of ASTM Standards*, Vol 03.01.

³ *Annual Book of ASTM Standards*, Vol 13.01.

designed and developed for specific regions of the spine such as the lumbar, thoracic, and cervical spine. Also, there exists different anatomical potential surgical approaches, which will result in different implant orientation at different levels of the spine.

3.2.7 *intervertebral body fusion device, n*—A structure (biologic or synthetic) that is placed in the disc space between two adjacent vertebral bodies to provide support for eventual arthrodesis of the two adjacent vertebral bodies.

3.2.8 *intradiscal height, n*—The straight-line distance along the Z axis between the unaltered simulated vertebral bodies—minimum height of 4 mm and a maximum height of 18 mm. See Fig. 1.

3.2.9 *load point, n*—The point through which the resultant force on the intervertebral device passes (that is, the geometric center of the superior fixture's sphere) (Figs. 2-5).

3.2.10 *maximum run out load or moment, n*—The maximum load or moment for a given test that can be applied to an intervertebral body fusion device assembly in which all of the tested constructs have withstood 5 000 000 cycles without functional or mechanical failure.

3.2.11 *mechanical failure, n*—That associated with the onset of a defect in the material (that is, initiation of fatigue crack or surface wear).

3.2.12 *offset angular displacement, n*—(Distance OB—Fig. 6)—Offset on the angular displacement axis equal to 10 % of the intradiscal height, H , divided by the outside diameter or height of the implant (maximum dimension of implant in XZ plane if not cylindrical) (for example, for a 10-mm intradiscal height and 16-mm intervertebral body fusion device assembly, distance $OB = 10 \text{ mm}/16 \text{ mm} (0.10)(180^\circ)/\pi = 3.6^\circ$).

3.2.13 *offset displacement, n*—(Distance OB—Fig. 6)—Offset on the displacement axis equal to 2 % of the intradiscal height (that is, 0.2 mm for a 10-mm intradiscal height).

3.2.14 *permanent deformation, n*—The remaining displacement (mm or degrees or radians) relative to the initial unloaded condition of the intervertebral body fusion device assembly after the applied load has been removed.

3.2.15 *stiffness (N/mm or N*mm/Degree (Radian)) (The Slope of Line OG—Fig. 6), n*—The slope of the initial linear portion of the load-displacement curve or the slope of the initial linear portion of the moment—angular displacement curve.

3.2.16 *test block, n*—The component of the test apparatus

for mounting the intervertebral body fusion device assembly for the intended test configuration.

3.2.17 *ultimate displacement (millimetres or degrees or radians) (Displacement OF—Fig. 6), n*—The displacement associated with the ultimate load or ultimate moment.

3.2.18 *ultimate load or moment (N or N*mm) (Point E—Fig. 6), n*—The maximum applied load, F , transmitted by the pushrod (assumed equal to force component parallel to and indicated by load cell), or the applied moment about the Z axis that can be applied to an intervertebral body fusion device assembly.

3.2.19 *yield displacement (Distance OA—Fig. 6), n*—The displacement (mm) or angular displacement (deg) when an interbody fusion device assembly has a permanent deformation equal to the offset displacement or the offset angular displacement.

3.2.20 *yield load or moment (Point D—Fig. 6), n*—The applied load, F , transmitted by the pushrod (assumed equal to force component parallel to and indicated by load cell), or the applied moment about the Z axis required to produce a permanent deformation equal to the offset displacement or the offset angular displacement.

4. Summary of Test Method

4.1 These test methods are proposed for the mechanical testing of intervertebral body fusion device assemblies specific to the lumbar, thoracic, and cervical spine.

4.2 Fatigue testing of the intervertebral body fusion device assemblies will simulate a motion segment via a gap between two polyacetal test blocks. The polyacetal will eliminate the effects of the variability of bone properties and morphology for the fatigue tests. The minimum ultimate tensile strength of the polyacetal blocks shall be no less than 61 MPa.

4.3 Static testing of the intervertebral body fusion device assemblies will simulate a motion segment via a gap between two stainless steel blocks. The minimum ultimate tensile strength of the blocks shall be no less than 1310 MPa.

4.4 The pushrod shall also be manufactured from stainless steel, which shall also have a minimum ultimate tensile strength no less than 1310 MPa.

4.5 Static and dynamic tests will evaluate the intervertebral body fusion device assembly. The user of this test method must decide which series of tests are applicable to the intervertebral body fusion device assembly in question. The user of this test

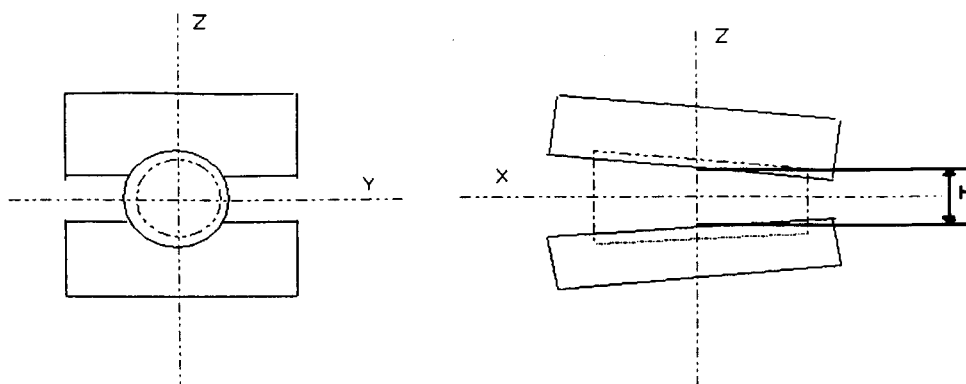

FIG. 1 Intradiscal Height Diagram

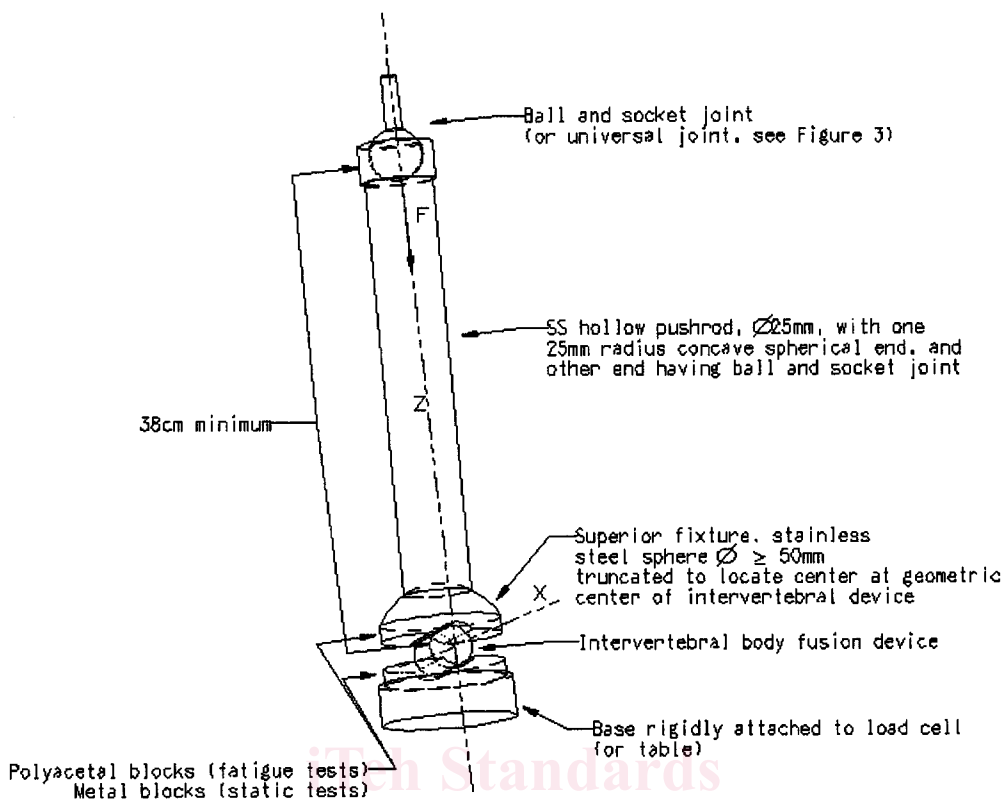

FIG. 2 Compression Testing Configuration

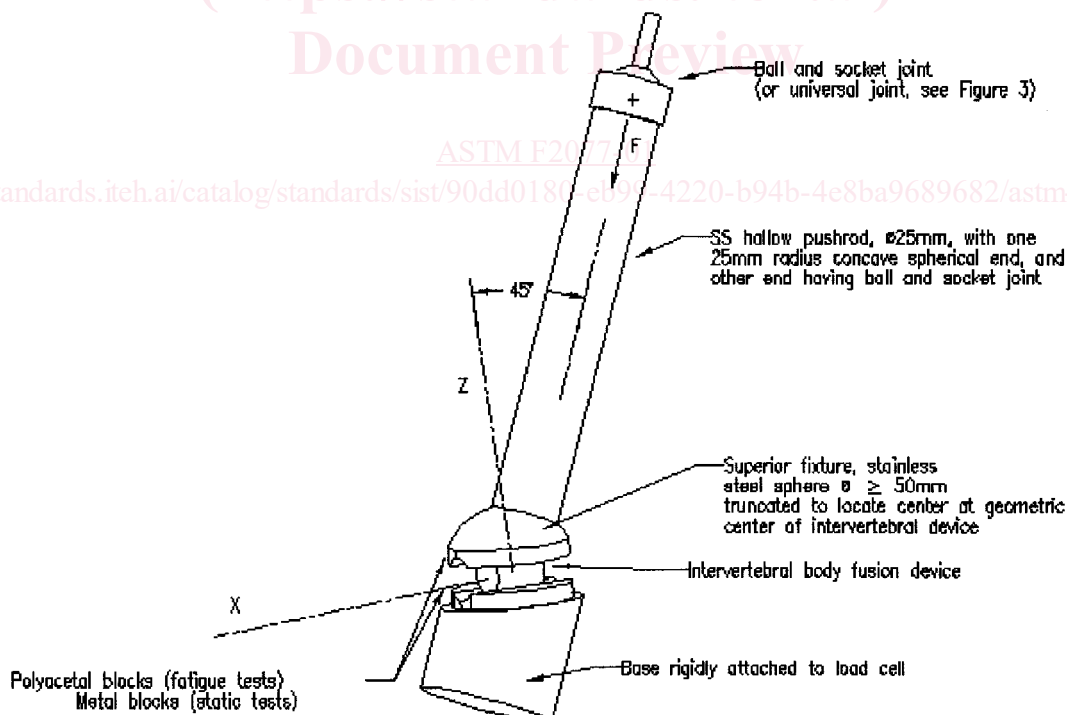

FIG. 3 Compression-Shear Testing Configuration

method may choose to use all or a selection of the tests described in this test method for testing a particular intervertebral body fusion device assembly.

5. Significance and Use

5.1 Intervertebral body fusion device assemblies are gener-

ally simple geometric-shaped devices which are often porous or hollow in nature. Their function is to support the anterior column of the spine to facilitate arthrodesis of the motion segment. This test method outlines materials and methods for

ASTM F 2077

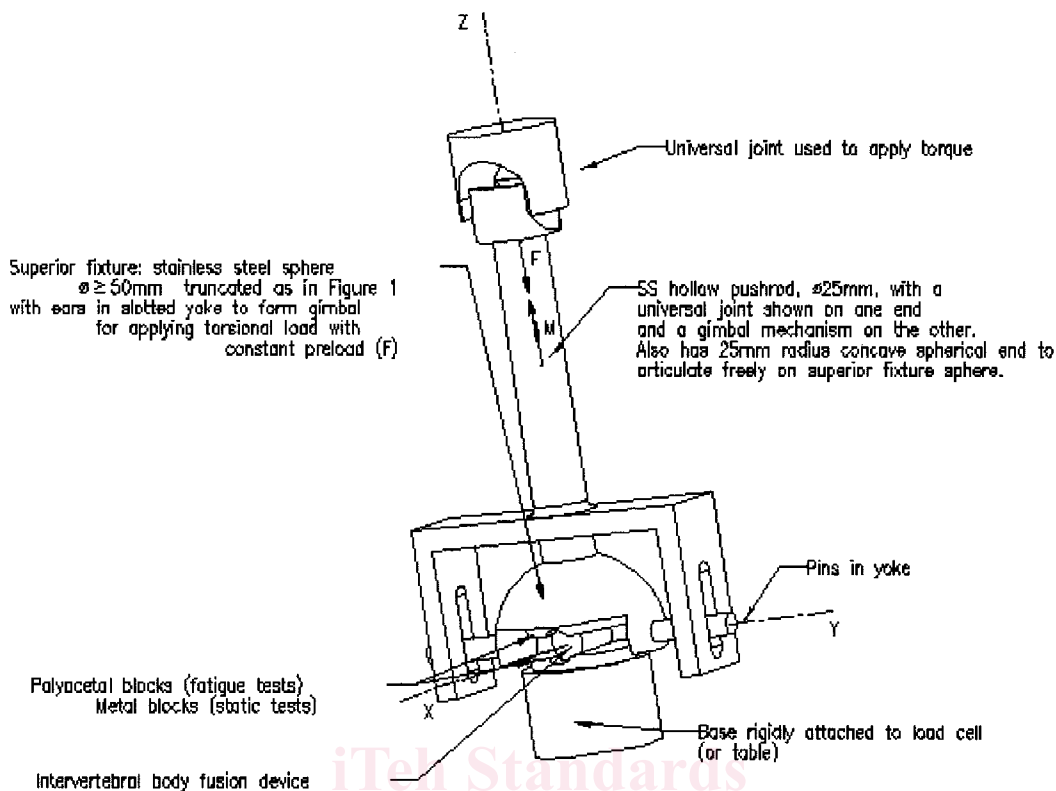

FIG. 4 Torsion Testing Configuration With Pin-Slot Gimbal

iteh Standards
 (https://standards.iteh.ai)
 Document Preview

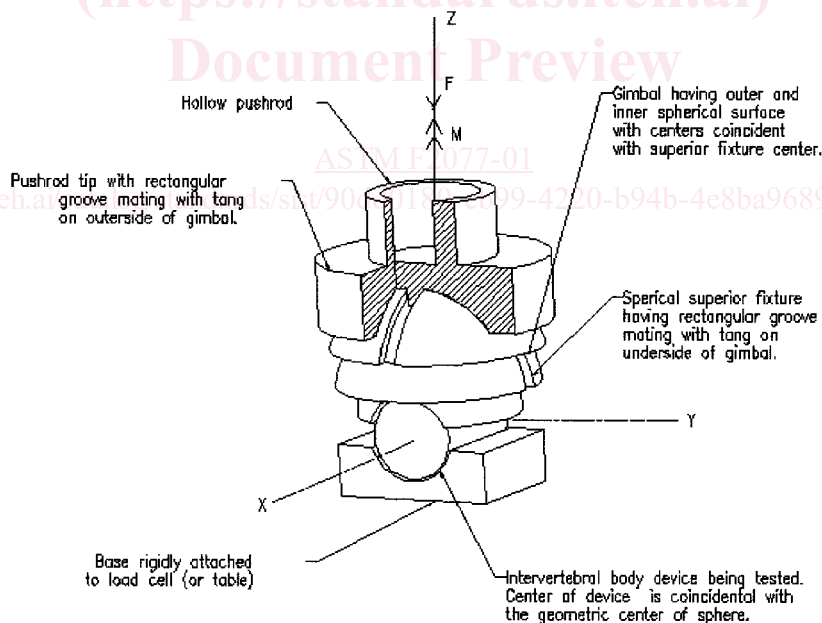

FIG. 5 Spherical Gimbal (Cross Section) for Torsion Testing Apparatus

the characterization and evaluation of the mechanical performance of different intervertebral body fusion device assemblies so that comparisons can be made between different designs.

5.2 This standard is designed to quantify the static and dynamic characteristics of different designs of intervertebral body fusion device assemblies. These tests are conducted in vitro to allow for analysis and comparison of the mechanical performance of intervertebral body fusion device assemblies to specific load modalities.

5.3 The loads applied to the intervertebral body fusion device assemblies may differ from the complex loading seen in vivo, and therefore, the results from these tests may not directly predict in vivo performance. The results, however, can be used to compare mechanical performance of different intervertebral body fusion device assemblies.

5.4 Since the environment may affect the dynamic performance of intervertebral body fusion device assemblies, dynamic testing in a saline environment may be considered.