

INTERNATIONAL  
STANDARD

**ISO**  
**7765-2**

First edition  
1994-08-15

---

---

**Plastics film and sheeting —  
Determination of impact resistance by the  
free-falling dart method —**

**Part 2:**  
**Instrumented puncture test**

[ISO 7765-2:1994](https://standards.iso.org/iso/7765-2:1994)

<https://standards.iso.org/iso/7765-2:1994> *Film et feuille de plastiques — Détermination de la résistance au choc par la méthode par chute libre de projectile —*

*Partie 2: Essai avec appareil de perforation*



Reference number  
ISO 7765-2:1994(E)

## Foreword

ISO (the International Organization for Standardization) is a worldwide federation of national standards bodies (ISO member bodies). The work of preparing International Standards is normally carried out through ISO technical committees. Each member body interested in a subject for which a technical committee has been established has the right to be represented on that committee. International organizations, governmental and non-governmental, in liaison with ISO, also take part in the work. ISO collaborates closely with the International Electrotechnical Commission (IEC) on all matters of electrotechnical standardization.

Draft International Standards adopted by the technical committees are circulated to the member bodies for voting. Publication as an International Standard requires approval by at least 75 % of the member bodies casting a vote.

International Standard ISO 7765-2 was prepared by Technical Committee ISO/TC 61, *Plastics*, Subcommittee SC 2, *Mechanical properties*.

ISO 7765 consists of the following parts, under the general title *Plastics film and sheeting* — *Determination of impact resistance by the free-falling dart method*:

- Part 1: *Staircase methods*
- Part 2: *Instrumented puncture test*

Annexes A and B of this part of ISO 7765 are for information only.

© ISO 1994

All rights reserved. Unless otherwise specified, no part of this publication may be reproduced or utilized in any form or by any means, electronic or mechanical, including photocopying and microfilm, without permission in writing from the publisher.

International Organization for Standardization  
Case Postale 56 • CH-1211 Genève 20 • Switzerland  
Printed in Switzerland

# Plastics film and sheeting — Determination of impact resistance by the free-falling dart method —

## Part 2:

## Instrumented puncture test

### 1 Scope

**1.1** The impact-penetration test described in the two parts of this International Standard is used for the assessment of plastic films and thin sheets (hereinafter referred to as films) under an impact stress applied at right angles to the plane of the film.

**1.2** Part 1 of this International Standard can be used if it is sufficient to characterize the impact behaviour of the film by an impact-failure energy. Part 2 is used if a force-deformation or a force-time diagram, recorded at practically constant velocity of the striker, is necessary for characterization of the impact behaviour. This applies if:

- measured quantities derivable only from this diagram are required or
- only a small number of test specimens are available.

**1.3** The test method is applicable to films of up to 1 mm thickness and makes it possible to compare impact-penetration forces, biaxial deformabilities and energy-absorption capacities of films. Furthermore, if required, the transition region between brittle and tough behaviour of the film under the conditions of testing can be determined by varying the temperature or the penetration velocity or the relative humidity (see also annex B).

NOTE 1 For thicknesses greater than 1 mm, ISO 6603-2 should be used.

**1.4** The test results are comparable only if the conditions for preparation of specimens, their thickness and surfaces, and the test conditions are identical. Comprehensive evaluation of the reaction to impact stress requires that the determinations are made as functions of deformation rate and temperature for different material variables, such as crystallinity and moisture content.

### 2 Normative references

The following standards contain provisions which, through reference in this text, constitute provisions of this part of ISO 7765. At the time of publication, the editions indicated were valid. All standards are subject to revision, and parties to agreements based on this part of ISO 7765 are encouraged to investigate the possibility of applying the most recent editions of the standards indicated below. Members of IEC and ISO maintain registers of currently valid International Standards.

ISO 291:1977, *Plastics — Standard atmospheres for conditioning and testing*.

ISO 4593:1993, *Plastics — Film and sheeting — Determination of thickness by mechanical scanning*.

ISO 6603-2:1989, *Plastics — Determination of multi-axial impact behaviour of rigid plastics — Part 2: Instrumented puncture test*.

ISO 7765-1:1988, *Plastics film and sheeting — Determination of impact resistance by the free-falling dart method — Part 1: Staircase methods*.

### 3 Definitions

For the purposes of this part of ISO 7765, the following definitions apply.

**3.1 peak force,  $F_M$ :** The maximum force exerted by the striker in the direction of impact during the test (see figures 1 to 3).

**3.2 deformation at peak force,  $s_M$ :** The deformation in the direction of impact at the centre of the test specimen corresponding to the peak force. For materials exhibiting a peak-force plateau, the deformation is taken at the centre of the plateau (see figure 1).

**3.3 energy to peak force,  $W_M$ :** The area under the force-deformation curve bounded by the origin, the peak force and the deformation at peak force (see figures 1 to 3).

**3.4 total penetration energy,  $W_T$ :** The total energy expended in penetrating the test specimen (see figures 1 to 3).

In contrast to the instrumented puncture test applied to test specimens made of brittle plastic (see ISO 6603-2), the force-deformation diagram of this test applied to film and sheeting frequently shows a clear point of first failure (failure point) indicated by a sharp drop in the force. If this is the case, and if the interested parties agree to use this point as a characteristic criterion, the following additional definitions may be used.

**3.5 failure force,  $F_F$ :** The force exerted by the striker in the direction of impact, measured at the failure point (see figures 1 and 2).

**3.6 failure deformation,  $s_F$ :** The deformation in the direction of impact at the centre of the test specimen, measured at the failure point (see figures 1 and 2).

**3.7 failure energy,  $W_F$ :** The area under the force-deformation curve bounded by the origin, the failure force and the failure deformation (see figures 1 and 2).

#### NOTES

2 If the force-deformation diagram as measured during the test is influenced strongly by dynamic resonance effects, a mean curve may be used to obtain the values of the parameters defined in 3.1 and 3.4. This, however, is seldom the case when plastic film is tested.

3 When comparing films of slightly different thicknesses, it is advisable to relate  $F_M$ ,  $F_F$ ,  $W_M$  and  $W_F$  to the thickness  $d$  of the specimen. Though the normalized values  $F_M/d$ ,

$F_F/d$ ,  $W_M/d$  and  $W_F/d$  do not allow a physically exact comparison between film specimens of different materials, the thickness dependence of these normalized values is negligible for similar materials (those with the same amount of crystallinity and the same orientation) provided the thicknesses do not differ by more than a factor of 1,5.

### 4 Principle

The test specimen is penetrated normal to its plane by a striker at a nominally uniform velocity. The resulting force-deformation or force-time diagram is electronically recorded. The test specimen is firmly clamped during the test.

The force-deformation diagram obtained in these tests shows several features of the material's behaviour under impact. For example, the fracture may be "brittle", "ductile", "tough" or characterized by initial damage or by crack initiation and propagation. In addition, dynamic effects may be present, such as load-cell/indenter resonance, specimen resonance and initial contact/inertia peaks (see figures 1 to 3).

In all cases care must be exercised in analysing these features because the operative mechanism and the trains of inference are not yet fully established, and are the subject of continuing research.

### 5 Apparatus

The apparatus consists of a mechanical test device for applying the test force, instruments for measuring the force and the deformation produced, and a thickness gauge.

#### 5.1 Test device

The essential components of the test device are the energy carrier (normally a falling mass, but a pneumatically, hydraulically or spring-driven mass or a pendulum impact-testing device may also be used), the striker, and the clamping device consisting of the test specimen support and the clamping ring (see figures 4 and 5).

The apparatus shall permit the test specimen to be punctured at the centre at a nominally constant velocity, perpendicular to the specimen surface. The force exerted on the test specimen in the direction of impact and the deformation of the specimen in the direction of impact shall be measurable or derivable (see figure 4). Equipment suitable for this are falling-dart machines, pendulums long enough for the penetration path to be regarded as approximately straight, or high-speed tensile-testing machines with suitable attachments.

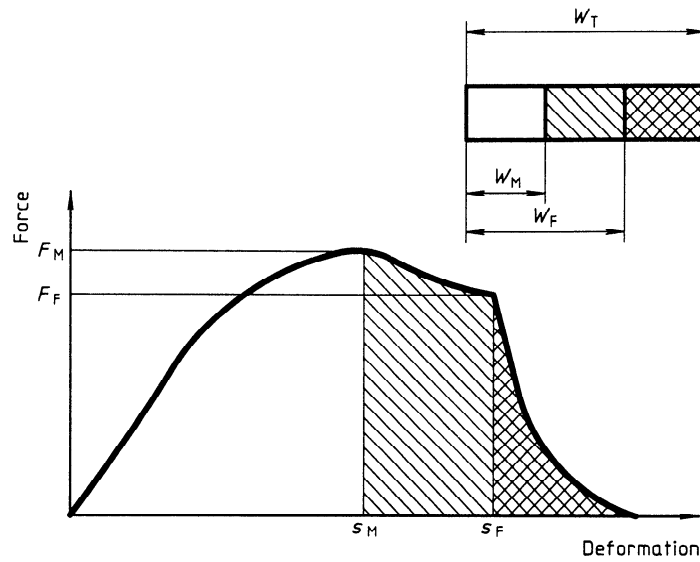

Figure 1 — Force-deformation diagram for very tough materials (schematic)

iTeh STANDARD PREVIEW  
(standards.iteh.ai)

ISO 7765-2:1994

<https://standards.iteh.ai/catalog/standards/sist/5fcc2caa-503d-4d47-a77f-096af895a11a/iso-7765-2-1994>

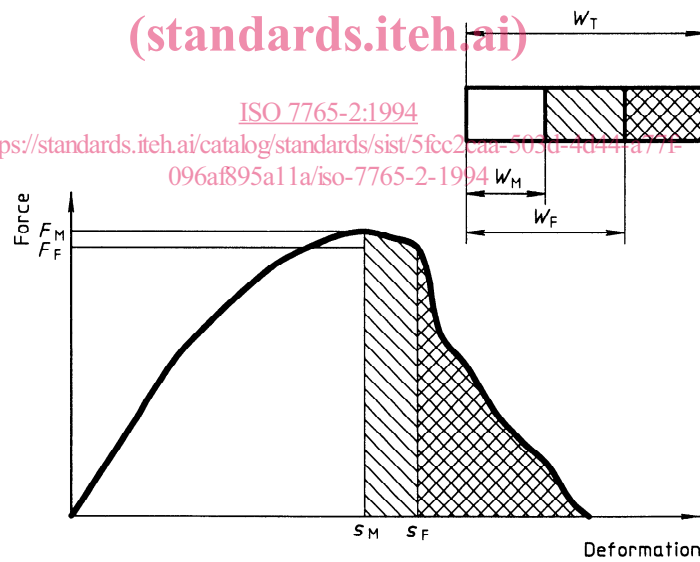

Figure 2 — Force-deformation diagram for tough materials (schematic)

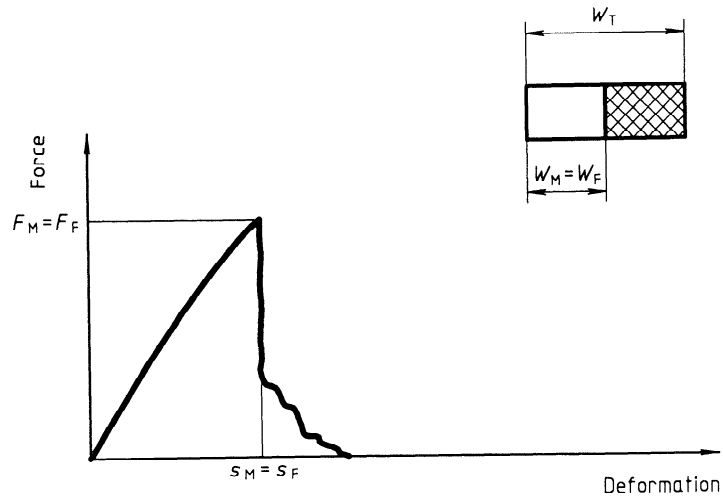
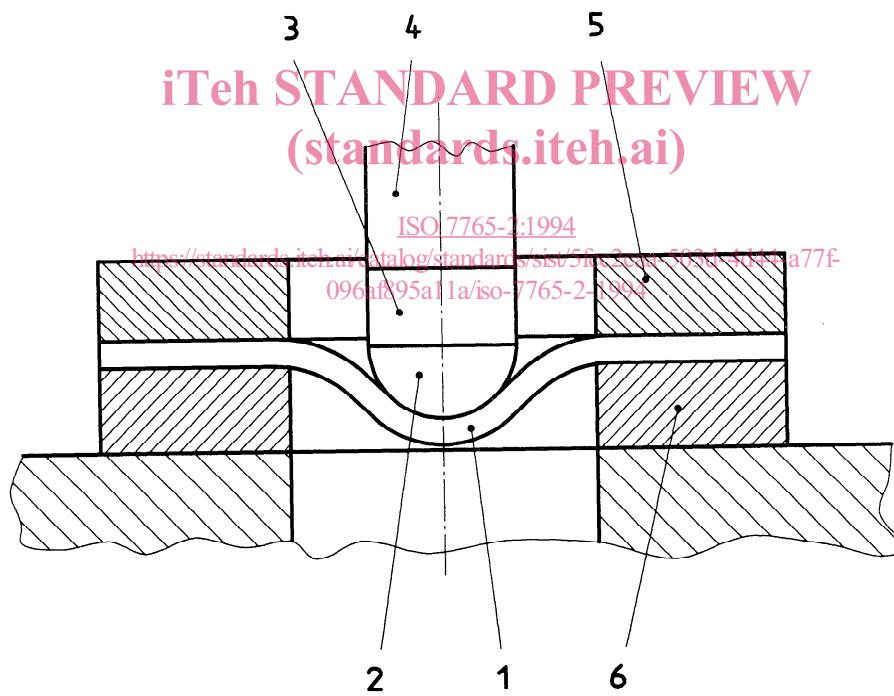

Figure 3 — Force-deformation diagram for brittle materials (schematic)



- 1 Test specimen
- 2 Hemispherical striker, diameter  $D_1$
- 3 Load cell (preferred position)
- 4 Shaft
- 5 Clamping ring
- 6 Test-specimen support, inside diameter  $D_2$

Figure 4 — Test apparatus (schematic)

Dimensions in millimetres

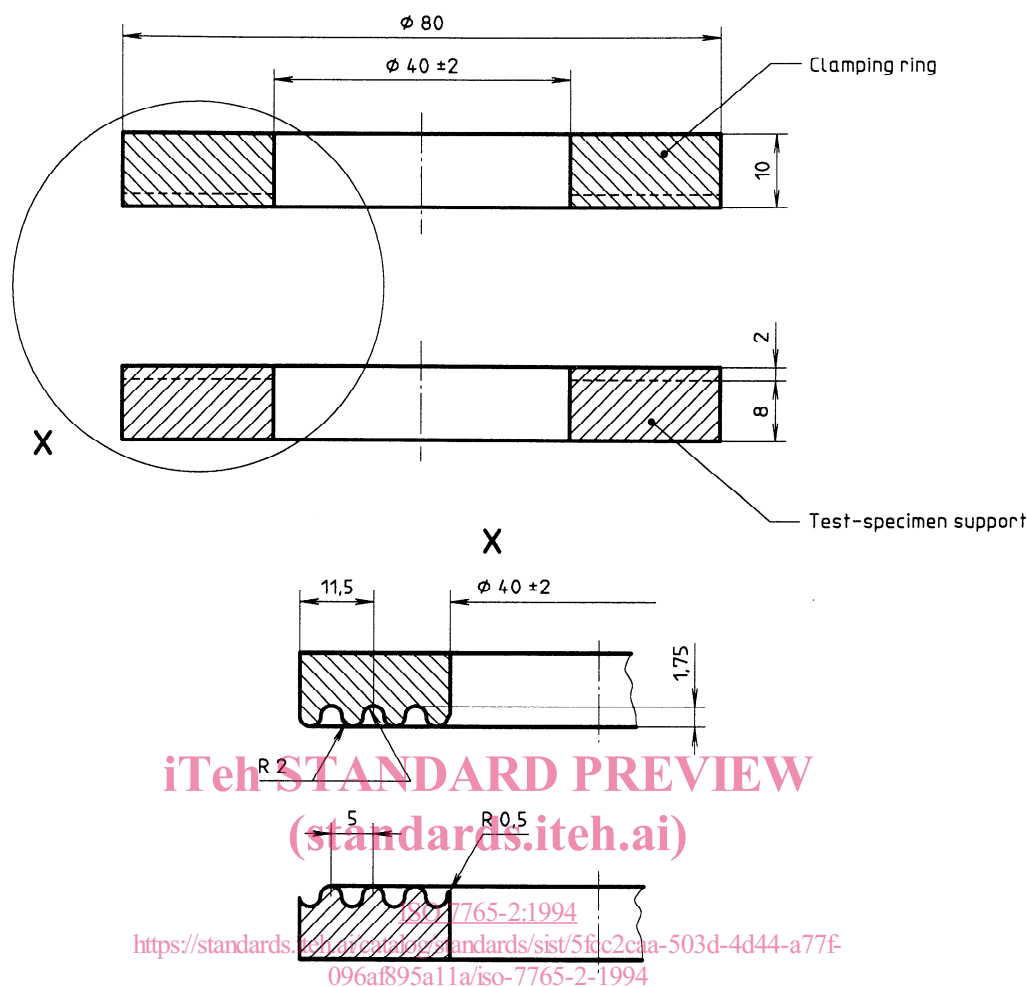

Figure 5 — Clamping device

### 5.1.1 Energy carrier

The impact energy (e.g. drop energy) available shall be large in comparison to the penetration energy absorbed  $W_T$ . This is because the influence of the test velocity (over the range of velocities used in the test) on the viscoelastic behaviour of plastics is relatively small; a decrease in the velocity of the striker of 20 % is acceptable.

This energy requirement is met by falling-dart machines if

$$m \geq 3W_T/gH_0$$

where

- $m$  is the falling mass, in kilograms;
- $g$  is the acceleration due to gravity (9,81 m/s<sup>2</sup>);
- $H_0$  is the height of fall, in metres;

$W_T$  is the total penetration energy, in joules.

The falling-dart system used shall be capable of holding and releasing a weighted striker so that the striker falls constrained by a guide or guide(s). The fall shall be largely without friction or losses through windage. Any friction shall be taken into account in the calculations.

#### NOTES

- 4 In most cases, a weighted striker with a total mass  $m$  of 10 kg is sufficient.
- 5 A velocity-measuring sensor should be placed close to the point of impact to eliminate errors due to friction between the dart and the guides and to air resistance.

With hydraulically driven high-speed tensile-testing machines, any deviation of the velocity during impact shall be proved, e.g. by plotting the deformation-time curves and checking their slope.

### 5.1.2 Striker

The preferred striker has a polished, hardened, hemispherical striking surface with a diameter  $D_1 = 20 \text{ mm} \pm 0,2 \text{ mm}$ . Alternatively, a striking surface of  $10 \text{ mm} \pm 0,1 \text{ mm}$  diameter may be used. The striker shall be constructed of steel.

The load cell on the striker shall be mounted as close as possible to the tip to minimize the effect of extraneous forces. An example is shown in figure 4.

The head of the striker may be powdered with talcum or lubricated with oil to reduce friction, provided that the interested parties agree on this procedure and use identical material. In some cases, this can reduce the statistical scatter of the results. It should be borne in mind, however, that lubricating the striker may influence the test results considerably.

The natural frequency  $f_n$  of the striker/load-cell assembly shall be higher than the value specified in 5.2.

### 5.1.3 Clamping device

The test-specimen clamping device shall have an inside diameter  $D_2$  of  $40 \text{ mm} \pm 2 \text{ mm}$ . The clamping device shall be constructed in such a way that the circular specimen can be clamped flat and held securely during the test. Moreover, the clamping device shall not cause any radial pre-stretching of the specimen greater than 0,01 %. Both requirements can be met with manual or hydraulic clamping faces. Furthermore, placing a ring of fine emery paper on the specimen support has been found to be useful. Figure 5 shows a recommended clamping-device design.

## 5.2 Instruments for measuring force, specimen deformation and specimen thickness

The instruments for measuring force and deformation shall be capable of measuring the force and deformation to within 5 % of their maximum value.

### EXAMPLE

If an electronic device has an accuracy of 0,4 % at full scale (FS) then, for a value of 20 % FS, the accuracy is 2 %.

### 5.2.1 Load cell

Because of the very short duration of the impact, only electronic load cells with a high natural frequency can be used. The shortest time interval  $\Delta t_{F,\min}$  which the

device shall be required to measure shall be  $\geq 5/f_n$ , where  $f_n$  is the natural frequency of the striker/load-cell assembly.

For the bandwidth  $B_T$  of the amplifier train (direct-current or carrier-frequency amplifier) with a lower bandwidth limit of 0 Hz, the following applies by analogy:

$$B_T \geq 16/\Delta t_{F,\min}$$

$$B_T = \left[ \sum_{j=1}^n 1/B_j^2 \right]^{-\frac{1}{2}}$$

where  $B_j$  is the individual bandwidth of the  $j^{\text{th}}$  amplifier stage.

NOTE 6 An example of such a measurement train is a piezoelectric load cell mounted between the striker and the shaft (see figure 4) and connected to a charge amplifier.

### 5.2.2 Device for measuring the specimen deformation

The deformation of the specimen in the direction of penetration can be determined directly with an electronic transducer, thus yielding a force-deformation curve. It is also possible to record a force-time curve and calculate the deformation in accordance with

7.4.

### 5.2.3 Thickness gauge

The instrument for measuring the thickness of the specimen shall fulfill the requirements of ISO 4593. It shall be capable of measuring the thickness  $d$  of the specimen to within  $1 \mu\text{m}$ .

## 6 Test specimens

### 6.1 Sampling and preparation of test specimens

Sampling shall be in accordance with the instructions on the relevant product standard. If no such instructions are given, specimens should preferably be taken from film sheeting or from a piece of the film to be tested. The specimens shall be  $80 \text{ mm} \pm 2 \text{ mm}$  in diameter. The cut edges need not be of any particular quality. They shall be as uniform as possible over the whole of the width and taken at right angles to the machine direction of the film. Non-homogeneous edge strips of film rolls shall not be used. If a fairly large number of specimens is required in order to determine the temperature dependence of the measured values, the specimens for the entire test series shall be mixed before testing.



## 6.2 Number of test specimens

A minimum of five test specimens shall be tested (in the case of arbitration, 20 specimens are required). If the dependence of the measured values on temperature, relative humidity or other parameters is to be determined, five specimens per measurement point are generally sufficient, even in the case of arbitration. The number of test specimens required is doubled if the test result depends on the side from which the film is penetrated.

## 6.3 Conditioning of test specimens

The test specimens shall be conditioned as required by the specifications for the material concerned or as agreed upon by the interested parties. Otherwise, select the most appropriate set of conditions from ISO 291.

## 7 Procedure

### 7.1 Test atmosphere

The test shall be carried out in one of the standard atmospheres specified in ISO 291. If measurements are to be made at different temperatures or relative humidities, the test specimens shall be maintained under each set of test conditions until the results show no further change at that particular temperature or humidity. This conditioning time decreases at higher test temperatures.

### 7.2 Measuring the thickness

Determine the thickness  $d$  of each specimen in accordance with ISO 4593 to the nearest  $1\ \mu\text{m}$ , taking the average of three measurements at equidistant points on the circumference of a circle of radius  $5\ \text{mm}$  located at the centre of the specimen.

### 7.3 Clamping the test specimen

The specimen shall be clamped flat. The stress caused by clamping shall not result in an elongation (pre-stretch) of more than  $0,01\ \%$  in the radial direction (see 5.1.3).

NOTE 7 The pre-stretch can be determined by means of a measuring microscope. The usual clamping device, however, always fulfills the above condition.

### 7.4 Impact-penetration test

The impact-penetration test is conducted with an impact velocity of  $4,4\ \text{m/s} \pm 0,2\ \text{m/s}$ , corresponding to

a height of fall  $H_0$  of  $1\ \text{m}$ . During the test, the speed shall not change by more than  $20\ \%$  of its value on striking the specimen (see the conditions for the falling mass in 5.1.1).

During the test, the force-deformation diagram or force-time curve shall be recorded. The values of the parameters defined in clause 4 shall be taken from the curve or read from the recording instrument, e.g. a transient recorder. If a satisfactory deformation curve cannot be obtained because of resonance effects, then the impact velocity shall be reduced to  $1\ \text{m/s}$ .

NOTE 8 Although the impact velocity of  $4,4\ \text{m/s}$  for testing of plastic films, even those made of relatively brittle materials, is normally not too high, the velocity may be reduced if the interested parties agree.

If there is any reason to believe that the results will depend upon which side of the test specimen faces the striker, both sides shall be tested separately (see also 6.2).

## 8 Expression of results

For routine characterization purposes, the peak of the force-deformation curve shall be used to determine the test results. If it is clear from the force-deformation curve and/or other information that crack initiation has occurred in the test specimen, the corresponding point (failure point) on the force-deformation curve can also be used to determine the test results.

If the test measurements are in the form of a force-deformation curve, the force and deformation at the characterization point can be read directly from the curve. The corresponding energy values are determined (by planimetry or by other suitable methods, e.g. electronic integration) from the area under the curve.

Should results be in the form of a force-time curve, the deformation  $s$ , in metres, at the peak force or the failure force is given by the approximation (see annex A and ISO 6603-2:1989, annex C)

$$s \approx (v_0 - p/3m) \times t \quad \dots (1)$$

where

- $m$  is the falling mass, in kilograms;
- $v_0$  is the impact velocity just before impact, in metres per second;
- $t$  is the time to peak force or the time to failure in seconds;