

TECHNICAL SPECIFICATION

Guideline for implementation of copy controlled multimedia interface
(standards.iteh.ai)

[IEC TS 62436:2008](#)

<https://standards.iteh.ai/catalog/standards/sist/9527d163-562c-4334-a26d-51a374b3efb2/iec-ts-62436-2008>



THIS PUBLICATION IS COPYRIGHT PROTECTED

Copyright © 2008 IEC, Geneva, Switzerland

All rights reserved. Unless otherwise specified, no part of this publication may be reproduced or utilized in any form or by any means, electronic or mechanical, including photocopying and microfilm, without permission in writing from either IEC or IEC's member National Committee in the country of the requester.

If you have any questions about IEC copyright or have an enquiry about obtaining additional rights to this publication, please contact the address below or your local IEC member National Committee for further information.

IEC Central Office
3, rue de Varembe
CH-1211 Geneva 20
Switzerland
Email: inmail@iec.ch
Web: www.iec.ch

About the IEC

The International Electrotechnical Commission (IEC) is the leading global organization that prepares and publishes International Standards for all electrical, electronic and related technologies.

About IEC publications

The technical content of IEC publications is kept under constant review by the IEC. Please make sure that you have the latest edition, a corrigenda or an amendment might have been published.

- Catalogue of IEC publications: www.iec.ch/searchpub

The IEC on-line Catalogue enables you to search by a variety of criteria (reference number, text, technical committee,...). It also gives information on projects, withdrawn and replaced publications.

- IEC Just Published: www.iec.ch/online_news/justpub

Stay up to date on all new IEC publications. Just Published details twice a month all new publications released. Available on-line and also by email.

- Electropedia: www.electropedia.org

The world's leading online dictionary of electronic and electrical terms containing more than 20 000 terms and definitions in English and French, with equivalent terms in additional languages. Also known as the International Electrotechnical Vocabulary online.

- Customer Service Centre: www.iec.ch/webstore/custserv

If you wish to give us your feedback on this publication or need further assistance, please visit the Customer Service Centre FAQ or contact us:

Email: csc@iec.ch
Tel.: +41 22 919 02 11
Fax: +41 22 919 03 00

PRESTANDARD PREVIEW
(standards.iteh.ai)
IEC TS 62436:2008
<https://standards.iteh.ai/catalog/standards/sist/9527d163-562c-4334-a26d-2177e028>

TECHNICAL SPECIFICATION

Guideline for implementation of copy controlled multimedia interface
(standards.iteh.ai)

IEC TS 62436:2008

<https://standards.iteh.ai/catalog/standards/sist/9527d163-562c-4334-a26d-51a374b3efb2/iec-ts-62436-2008>

INTERNATIONAL
ELECTROTECHNICAL
COMMISSION

PRICE CODE

Q

CONTENTS

FOREWORD.....	3
INTRODUCTION.....	5
1 Scope.....	6
2 Normative references	6
3 Terms, definitions and abbreviations	6
3.1 Terms and definitions	6
3.2 Abbreviations	7
4 Relation between interface standards and specifications	7
4.1 IEC standards with copy control information	7
4.2 Relation between IEC standards.....	7
4.3 IEC 60958 conformant data format.....	8
4.3.1 The structure defined in IEC 61883-6	8
4.3.2 Application to the other interface specification	10
4.4 IEC 61937 format based on IEC 60958.....	10
5 Information for copy control	11
5.1 Audio	11
5.1.1 SCMS.....	11
5.1.2 Other information.....	11
5.2 Video	11
6 Implementation of copy control information of audio	11
6.1 IEC 61937 implementation	11
6.2 IEC 61883-6 implementation.....	12
7 Implementation of copy control information of audio accompanied with video	12
8 Implementation of other information.....	12
Annex A (informative) Relation between IEC standards and other specifications.....	13
Annex B (informative) Copy control information of audio accompanied with video	15
Bibliography.....	16
Figure 1 – The relationship between IEC standards	8
Figure 2 – Sub-frame format	9
Figure 3 – IEC 60958 conformant data format.....	9
Figure 4 – The logical structure of IEC 60958 conformant data format	10
Figure 5 – IEC 61937 data area	10
Figure A.1 – The relationship between IEC 60958, AES3 and CP-340	13
Figure A.2 – The relationship IEEE1394 and IEC 61883-6	14
Table 1 – IEC standards with copy control information	7
Table 2 – IEC 60958 conformant data format.....	9

INTERNATIONAL ELECTROTECHNICAL COMMISSION

**GUIDELINE FOR IMPLEMENTATION OF
COPY CONTROLLED MULTIMEDIA INTERFACE**

FOREWORD

- 1) The International Electrotechnical Commission (IEC) is a worldwide organization for standardization comprising all national electrotechnical committees (IEC National Committees). The object of IEC is to promote international co-operation on all questions concerning standardization in the electrical and electronic fields. To this end and in addition to other activities, IEC publishes International Standards, Technical Specifications, Technical Reports, Publicly Available Specifications (PAS) and Guides (hereafter referred to as "IEC Publication(s)"). Their preparation is entrusted to technical committees; any IEC National Committee interested in the subject dealt with may participate in this preparatory work. International, governmental and non-governmental organizations liaising with the IEC also participate in this preparation. IEC collaborates closely with the International Organization for Standardization (ISO) in accordance with conditions determined by agreement between the two organizations.
- 2) The formal decisions or agreements of IEC on technical matters express, as nearly as possible, an international consensus of opinion on the relevant subjects since each technical committee has representation from all interested IEC National Committees.
- 3) IEC Publications have the form of recommendations for international use and are accepted by IEC National Committees in that sense. While all reasonable efforts are made to ensure that the technical content of IEC Publications is accurate, IEC cannot be held responsible for the way in which they are used or for any misinterpretation by any end user.
- 4) In order to promote international uniformity, IEC National Committees undertake to apply IEC Publications transparently to the maximum extent possible in their national and regional publications. Any divergence between any IEC Publication and the corresponding national or regional publication shall be clearly indicated in the latter.
- 5) IEC provides no marking procedure to indicate its approval and cannot be rendered responsible for any equipment declared to be in conformity with an IEC Publication.
- 6) All users should ensure that they have the latest edition of this publication.
- 7) No liability shall attach to IEC or its directors, employees, servants or agents including individual experts and members of its technical committees and IEC National Committees for any personal injury, property damage or other damage of any nature whatsoever, whether direct or indirect, or for costs (including legal fees) and expenses arising out of the publication, use of, or reliance upon, this IEC Publication or any other IEC Publications.
- 8) Attention is drawn to the Normative references cited in this publication. Use of the referenced publications is indispensable for the correct application of this publication.
- 9) Attention is drawn to the possibility that some of the elements of this IEC Publication may be the subject of patent rights. IEC shall not be held responsible for identifying any or all such patent rights.

The main task of IEC technical committees is to prepare International Standards. In exceptional circumstances, a technical committee may propose the publication of a technical specification when

- the required support cannot be obtained for the publication of an International Standard, despite repeated efforts, or
- the subject is still under technical development or where, for any other reason, there is the future but no immediate possibility of an agreement on an International Standard.

Technical specifications are subject to review within three years of publication to decide whether they can be transformed into International Standards.

IEC 62436, which is a technical specification, has been prepared by technical area 4: Digital system interfaces and protocols, of IEC technical committee 100: Audio, video and multimedia systems and equipment.

The text of this technical specification is based on the following documents:

Enquiry draft	Report on voting
100/1231/DTS	100/1334/RVC

Full information on the voting for the approval of this technical specification can be found in the report on voting indicated in the above table.

This publication has been drafted in accordance with the ISO/IEC Directives, Part 2.

The committee has decided that the contents of this publication will remain unchanged until the maintenance result date indicated on the IEC web site under "<http://webstore.iec.ch>" in the data related to the specific publication. At this date, the publication will be

- transformed into an International standard,
- reconfirmed,
- withdrawn,
- replaced by a revised edition, or
- amended.

A bilingual version of this publication may be issued at a later date.

iTeh STANDARD PREVIEW **(standards.iteh.ai)**

[IEC TS 62436:2008](#)

<https://standards.iteh.ai/catalog/standards/sist/9527d163-562c-4334-a26d-51a374b3efb2/iec-ts-62436-2008>

INTRODUCTION

Various IEC standards have included methods for transmission of copy control information at the time when they were developed. For instance, IEC 61119-6 defines copyright status bit for DAT recorder, and IEC 60958-3 defines the L bit that is specified in IEC 61119-6.

The current consumer products become more complex and use the many IEC standards in one product.

For instance, a DVD player produces its high quality audio signal securely through IEC 61883-6, it also performs CD quality audio signal through IEC 60958 or IEC 61937, and the DVD player can produce audio signals through the other interface using IEC 60958 conformant data format, defined in IEC 61883-6.

Another example is a digital video recorder with hard disk drive or DVD that produces audio signal to the other audio recorder using IEC 60958 or IEC 61883-6.

These consumer products use many interface standards and should give copy control information and other information appropriately.

This guideline describes

- the relation between digital interface standards,
- the relation of copy control information and related information,
- the method for information implementation.

[IEC TS 62436:2008](https://standards.iteh.ai/catalog/standards/sist/9527d163-562c-4334-a26d-51a374b3efb2/iec-ts-62436-2008)

<https://standards.iteh.ai/catalog/standards/sist/9527d163-562c-4334-a26d-51a374b3efb2/iec-ts-62436-2008>

GUIDELINE FOR IMPLEMENTATION OF COPY CONTROLLED MULTIMEDIA INTERFACE

1 Scope

This Technical Specification gives a guideline for the implementation of the audio and video interfaces with copy control information.

2 Normative references

The following referenced documents are indispensable for the application of this document. For dated references, only the edition cited applies. For undated references, the latest edition of the referenced document (including any amendments) applies.

IEC 60958 (all parts), *Digital audio interface*

IEC 60958-1, *Digital audio interface – Part 1: General*

IEC 60958-3, *Digital audio interface – Part 3: Consumer applications*

IEC 61119-6, *Digital audio tape cassette system (DAT) – Part 6: Serial copy management system*

IEC 61880-2, *Video systems (525/60) – Video and accompanied data using the vertical blanking interval – Analogue interface – Part 2: 525 progressive scan system*

IEC 61883-6, *Consumer audio/video equipment – Digital interface – Part 6: Audio and music data transmission protocol*

IEC 61909, *Audio recording – Minidisc system*

IEC 61937 (all parts), *Digital audio – Interface for non-linear PCM encoded audio bitstreams applying IEC 60958*

IEC 61937-1, *Digital audio – Interface for non-linear PCM encoded audio bitstreams applying IEC 60958 – Part 1: General*

IEC 61937-2, *Digital audio – Interface for non-linear PCM encoded audio bitstreams applying IEC 60958 – Part 2: Bust-info*

IEC 62375, *Video systems (625/50 progressive) – Video and accompanied data using the vertical blanking interval – Analogue interface*

3 Terms, definitions and abbreviations

3.1 Terms and definitions

For the purposes of this document, the following terms and definitions apply.

3.1.1

IEC 60958 conformant data format

data format that has conformance with the data protocol defined in of IEC 60958

3.2 Abbreviations

SCMS	serial copy management system, for copy management of one generation
CCI	copy control information
CGMS-A	copy generation management system on analogue video interface

4 Relation between interface standards and specifications

4.1 IEC standards with copy control information

IEC standards that have information of copy control are described in Table 1, these standards are the subjects of this technical specification.

Table 1 – IEC standards with copy control information

IEC standard	Description of copy control information
IEC 60958-3	Digital audio interface, contains SCMS information
IEC 61937-1, IEC 61937-2, IEC 61937-3, IEC 61937-4, IEC 61937-5, IEC 61937-6, IEC 61937-7, IEC 61937-8, IEC 61937-9	Digital audio interface, contains SCMS information (note 1)
IEC 61883-6	Digital audio interface, contains SCMS and Audio CCI (note 2)
IEC 61119-6	Digital audio tape cassette system, defines SCMS
IEC 61909	Minidisc system, describes SCMS
IEC 61880-2	525 progressive video system, defines VBI with CGMS-A
IEC 62375	625 progressive video system, defines VBI with CGMS-A
NOTE 1 IEC 61937 does not describe SCMS that come from the structure of IEC 60958-1	
NOTE 2 SCMS is contained in the IEC 60958 conformant data format.	

4.2 Relation between IEC standards

Figure 1 shows the relation between digital audio interface standards IEC 60958, IEC 61937 and IEC 61883-6.

IEC 60958-1 is the fundamental standard of these related standards, and it defines the basic structure. The application standards derived from IEC 60958-1 for the linear PCM audio data transmission are IEC 60958-3 for consumer use and IEC 60958-4 for professional use.

IEC 61937 is derived from IEC 60958, it specifies the data packet structure based on IEC 60958-1, it is mainly for the transmission of compressed audio data. IEC 61937-1 and IEC 61937-2 specify the general structure. In part 1 and part 2 of IEC 61937, transmission method for the specific compressed audio format are specified from part 3 to part 9. Also IEC 62105 specifies the receiver data transmission using IEC 61937-1 structure.

IEC 61883-6 specifies IEC 60958 conformant data format, this format defines IEC 60958-1 structure in IEC 61883-6. IEC 60958 conformant data format can transmit IEC 60958-1 and all of its derivative standards.

IEC 60958 conformant data format can be used in any other interface specification applying the definition of the structure of IEC 60958-1.

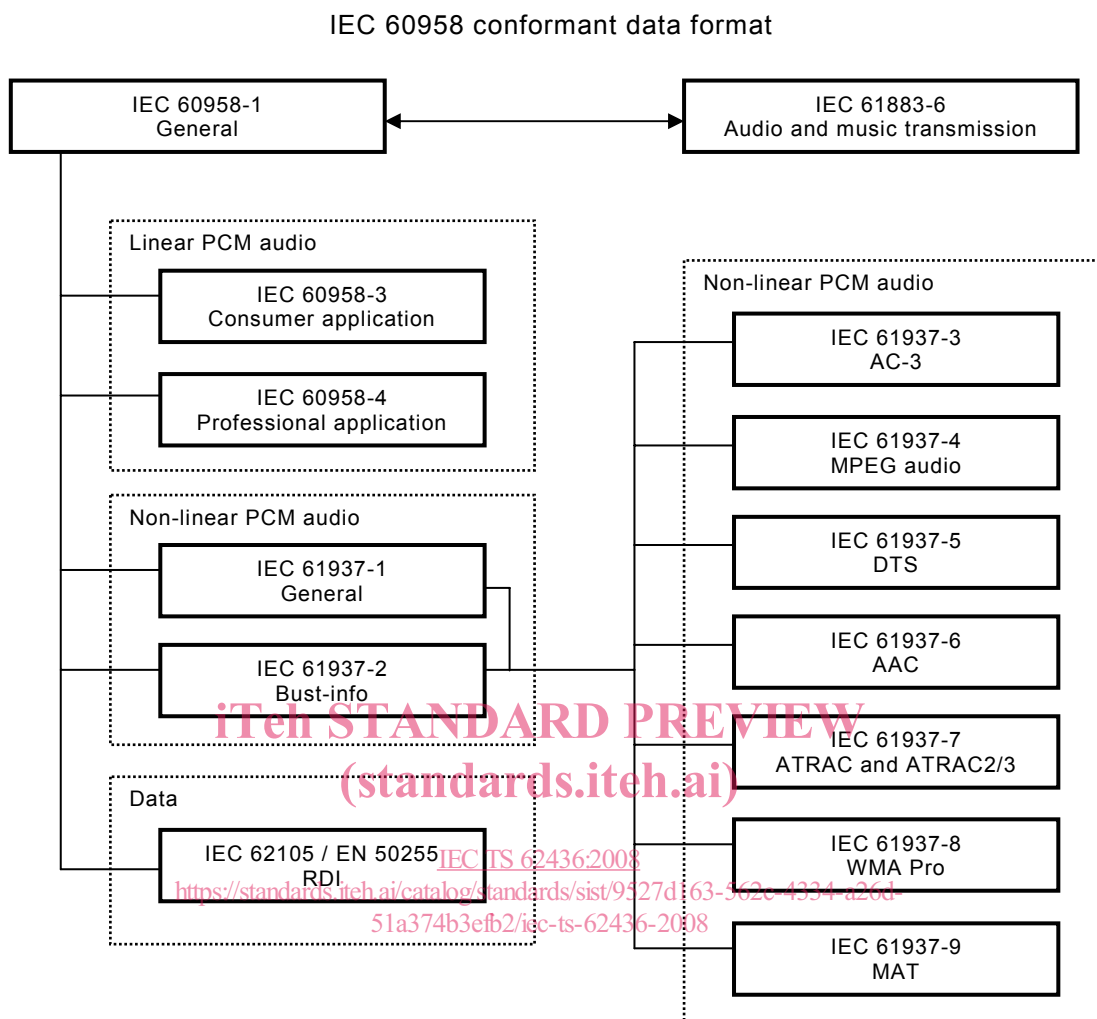

IEC 195/08

Figure 1 – The relationship between IEC standards

4.3 IEC 60958 conformant data format

4.3.1 The structure defined in IEC 61883-6

IEC 60958 conformant data format is defined by IEC 61883-6, this format defines the use of the frame format and sub-frame format defined in IEC 60958-1 as it is.

Figure 2 shows the sub-frame format of IEC 60958 defined in IEC 60958-1. Figure 3 shows IEC 60958 conformant data format defined in IEC 61883-6. This defines the sync preamble in 2 bits as described in Table 2. The 32 bit data of IEC 61883-6 consists of an 8 bit label and 24 bit data that are called AM824 data, and the label from 00₁₆ to 3F₁₆ are assigned to IEC 60958 conformant data format including the sync preambles and the bits V, U, C and P.

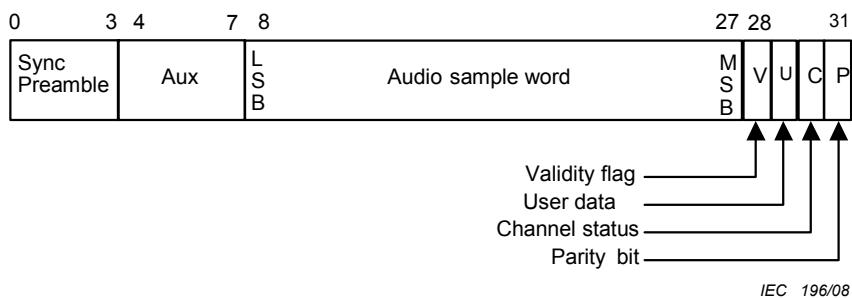

Figure 2 – Sub-frame format

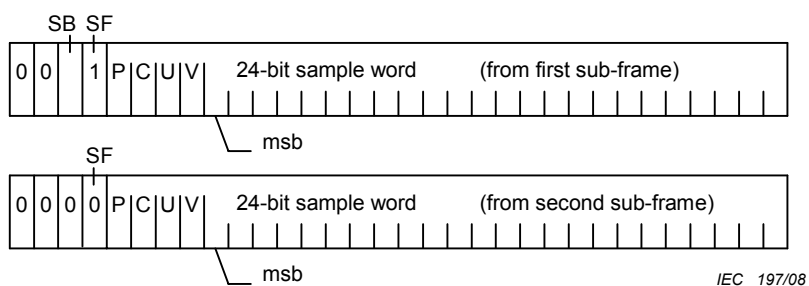

Figure 3 – IEC 60958 conformant data format

Table 2 – IEC 60958 conformant data format
 (standards.iteh.ai)

SB (Start of Block) and SF (Start of Frame) definitions				
LABEL	SB	SF	Description	Equivalent IEC 60958 preamble codes
00 ₁₆ - 0F ₁₆	0	0	Second subframe of IEC 60958 frames 0 to 191	W,Y
10 ₁₆ - 1F ₁₆	0	1	First subframe of IEC 60958 frames 1 to 191	M,X
20 ₁₆ - 2F ₁₆	1	0	Reserved	-
30 ₁₆ - 3F ₁₆	1	1	First subframe of IEC 60958 frame 0	B,Z

Figure 4 shows the logical structure of IEC 60958 conformant data format of IEC 61883-6 that enables to transmit all of IEC 60958-1 derivative standards as Figure 1 shows.