



Designation: F 2086 – 01

Standard Test Method for Pass Through Flux of Circular Magnetic Sputtering Targets, Method 2¹

This standard is issued under the fixed designation F 2086; the number immediately following the designation indicates the year of original adoption or, in the case of revision, the year of last revision. A number in parentheses indicates the year of last reapproval. A superscript epsilon (ϵ) indicates an editorial change since the last revision or reapproval.

1. Scope

1.1 This test method covers measuring the dc magnetic field transmitted through a round ferromagnetic sputtering target (“pass through flux” or “PTF”). In this test method the source magnetic field is in the test target’s radial direction.

1.2 Planar disk-shaped targets in the diameter range 5 to 8 in. inclusive (125 to 205 mm inclusive) and of thickness 0.1 to 0.5 in. inclusive (2.5 to 13 mm) may be characterized by this procedure.

1.3 This test method is also applicable to targets having an open center, for example, to targets 5-in. outside diameter by 2.5-in. inside diameter by 0.25-in. thick (127-mm outside diameter by 63.5-mm inside diameter by 6.35-mm thick).

1.4 Targets of various diameters and thicknesses are accommodated by suitable fixturing to align the piece under test with the source magnet mounted in the test fixture. Tooling, covering several popular target designs is specified in this procedure. Additional target configurations may be tested by providing special tooling. When special fixturing is used all parties concerned with the testing must agree to the test setup.

1.5 The values stated in inch-pound units are to be regarded as the standard. The values given in parentheses are for information only.

1.6 *This standard does not purport to address all of the safety concerns, if any, associated with its use. It is the responsibility of the user of this standard to establish appropriate safety and health practices and determine the applicability of regulatory limitations prior to use.*

2. Terminology

2.1 Definitions:

2.1.1 *pass through flux (PTF), n—for purposes of this standard, the “pass through flux” is the dc magnetic field transmitted through a ferromagnetic sputtering target, from one face to the opposite face.*

2.1.1.1 *Discussion—PTF is also frequently called “leakage flux.”*

2.1.2 *reference field, n—for purposes of this standard, the “reference field” is the dc magnetic field measured with the Hall probe Gaussmeter when no sputtering target is in position on the test stand. The strength of the reference field depends upon the height and position of the Hall probe relative to the source magnet.*

2.1.3 *source field, n—for purposes of this standard, the “source field” is the dc magnetic field measured with the Hall probe at the top surface of the target support table.*

3. Summary of Test Method

3.1 The sputtering target under test is mounted on a test fixture in which a permanent horseshoe-shaped magnet is held in proximity to one of the flat planar faces of the target. A Hall probe Gaussmeter is used to measure the dc magnetic field penetrating the target and entering the air space from the target’s opposite face.

4. Significance and Use

4.1 It is standard practice to use magnetron cathode sputter deposition sources in manufacturing thin film magnetic data storage media. But a ferromagnetic sputtering target tends to shunt a sputtering cathode’s magnetic field, thus reducing the efficiency of the sputtering process.

4.2 Makers of sputtering targets have developed various means of controlling alloy microstructure to minimize the undesirable cathode shunting effect. Because of their differing manufacturing methods, however, the targets of one supplier may have magnetic properties significantly better or worse than those of another, even when the alloy compositions are the same.

4.3 This test method permits comparing the magnetic shunting power of magnetic targets under a standard test condition. The results are useful to sputtering target suppliers and buyers in predicting target performance, in specifying target quality, and in qualifying incoming target shipments. This test may also be useful in quantifying target improvement efforts.

4.4 Manufacturing process steps which lower a target material’s magnetic permeability tend to increase the PTF, and visa versa. It would in principle be possible to predict the PTF by accumulating sufficient permeability data, and knowing the

¹ This test method is under the jurisdiction of ASTM Committee F01 on Electronics and is the direct responsibility of Subcommittee F01.17 on Sputter Metallization.

Current edition approved Feb. 10, 2001. Published April 2001.

target thickness and the field intensity of the magnetic assembly used for magnetron sputtering.

5. Interferences

5.1 The magnetic test fixture must be located in an area free of extraneous ferromagnetic materials and strong magnetic fields that would interfere with the source magnet – test specimen dc magnetic field configuration.

5.2 The “magnetic conditioning” effect is strong in some sputtering target alloys. It is important to verify that the target under test is magnetically stabilized before finalizing a data set (see 9.2 and 9.10).

6. Apparatus

6.1 This test method requires the use of a special test fixture. Its construction is specified in the Appendix.

6.2 *Gaussmeter*,² is required, equipped with a portable transverse-field Hall probe blade nominally 0.040-in. thick by 0.170-in. wide by 2.5-in. long (1.0-mm by 4.3-mm by 64-mm). The Gaussmeter must be capable of measuring dc magnetic fields in the range 1 Gauss to 3500 Gauss, inclusive, to an accuracy of $\pm 2\%$. This unit is designated the “measuring Gaussmeter,” and is used for making the magnetic field measurements specified in this test method.

6.2.1 It is important that the semiconductor Hall probe sensing element be mounted at the extreme tip end of the probe. The distance from the probe tip to the center of the sensing element must not exceed 0.030 in. (0.75 mm).

6.3 It is convenient to have a second Gaussmeter available, also equipped with a portable transverse-field Hall probe blade. This unit must be capable of measuring dc magnetic fields in the range 1 Gauss to 50 Gauss, inclusive, to an accuracy of $\pm 20\%$. This unit is referred to in 8.1 as the “screening Gaussmeter.” It is used to monitor residual magnetic fields in test specimen sputtering targets.

NOTE 1—If a “screening Gaussmeter” is not available, the targets under test must be degaussed and verified (8.3) using the measuring Gaussmeter before starting Section 7.

6.4 *Demagnetizer*,³ is needed which is capable of removing the remnant magnetization in sputtering targets to be tested.

7. Preparation of Apparatus

7.1 Verify that the source magnet is securely clamped with the midpoint between the two pole faces located 5.750 ± 0.015 in. (146.1 ± 0.4 mm) from the end of the baseplate. This is illustrated in Fig. 1

7.2 Verify that the pole faces of the source magnet are in light contact with the bottom of the target support table. Adjustment of the magnet’s vertical position can be made by loosening the magnet clamp screws, inserting nonmagnetic shims under the magnet, and retightening the clamp screws. Recheck magnet location, per 7.1, if shims are adjusted.

7.3 Activate, zero, and calibrate the measuring Gaussmeter (6.2) using the manufacturer’s instructions.

7.4 Mount the Gaussmeter probe in the fixture’s Hall probe support tube. The bottom tip of the probe should extend 0.050 ± 0.025 in. (1.25 ± 0.64 mm) beyond the support tube. Mounted properly, the probe tip will be clearly visible, sticking out of its support. Gently tighten the nylon clamping screws to secure and center the Hall probe in position in the probe support tube. Excessive tightening may result in damage to the probe that can affect test results.

7.5 By visual sighting, align the Hall probe as indicated in Fig. 1, but with the probe tip close to but not touching the target support table. The Hall probe should be centered as accurately as possible between the magnet poles, and the flats of the probe blade should be parallel to the fixture’s short dimension. Loosen the post attachment screw at the baseplate and adjust the Hall probe post position, if necessary, to achieve the correct location.

7.5.1 To make the adjustments indicated in this and subsequent paragraphs it may be necessary to loosen and retighten the collars on the Hall probe support post and the appropriate nylon clamping screws which secure other parts of the apparatus.

7.6 Lower the support arm until the Hall probe blade tip is in bare (light) contact with the target support table. Note the Gaussmeter reading. Swing (rotate) the cross arm to center the probe blade over the magnetic poles, and slightly rotate the probe support tube, as necessary, to maximize the Gaussmeter reading. The proper position is achieved when the Gaussmeter reading indicates a clear maximum in the magnetic field strength.

NOTE 2—If a clear maximum cannot be identified, the Hall probe blade is not adequately centered in the probe support tube (see 7.4), or the blade is not in correct transverse alignment (7.6). Repeat 7.4 or 7.6 as required to provide a discernible maximum point in step 7.6.

7.6.1 The maximum Gaussmeter reading at the target support table (7.6) is the “source field” (2.1.3).

NOTE 3—Measuring and recording (preferably using an SPC control chart) the source field provides important information about the stability of the measuring system. A significant deviation in source field strength may indicate a problem with the Hall probe, or a change in the operating environment that may influence the test results.

7.7 The source field (7.6.1) must be in the range 900 ± 50 Gauss.

7.7.1 If the dc magnetic source field is not in the required range (7.7) the Hall probe should be inspected and replaced if any evidence of damage is observed. If there are no indications of probe damage the measurement of the source field (7.2-7.6) should be repeated, as needed, until the requirement of 7.7 is satisfied.

7.8 Lift the probe support cross arm to a position in which the clearance between the Hall probe tip and the top surface of

² Three Gaussmeters are known to the committee to be suitable. These are: Model 4048, fitted with Model T4048-001 Hall probe, or Model 5070 fitted with Model STH 57-0404 probe, all from F. W. Bell Company, 6120 T Hanging Moss Rd., Orlando, FL 32807; or Model 410-SCT, fitted with model MPEC-410-3 Probe Extension Cable from Lake Shore Cryotronics, Inc., 575 McCorkle Blvd., Westerville, OH 43082.

³ The sole source of supply of the demagnetizer, 60-Hz hand held coil known to the committee at this time is Realistic High Power Video/Audio Tape Eraser, catalog number 44-233A from Radio Shack. If you are aware of alternative suppliers, please provide this information to ASTM Headquarters. Your comments will receive careful consideration at a meeting of the responsible technical committee,¹ which you may attend.

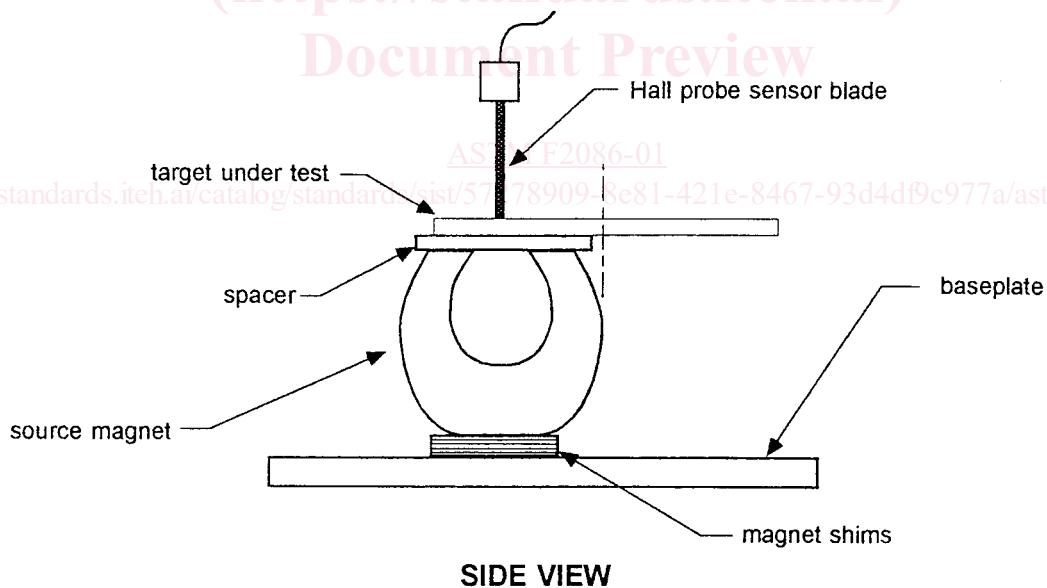
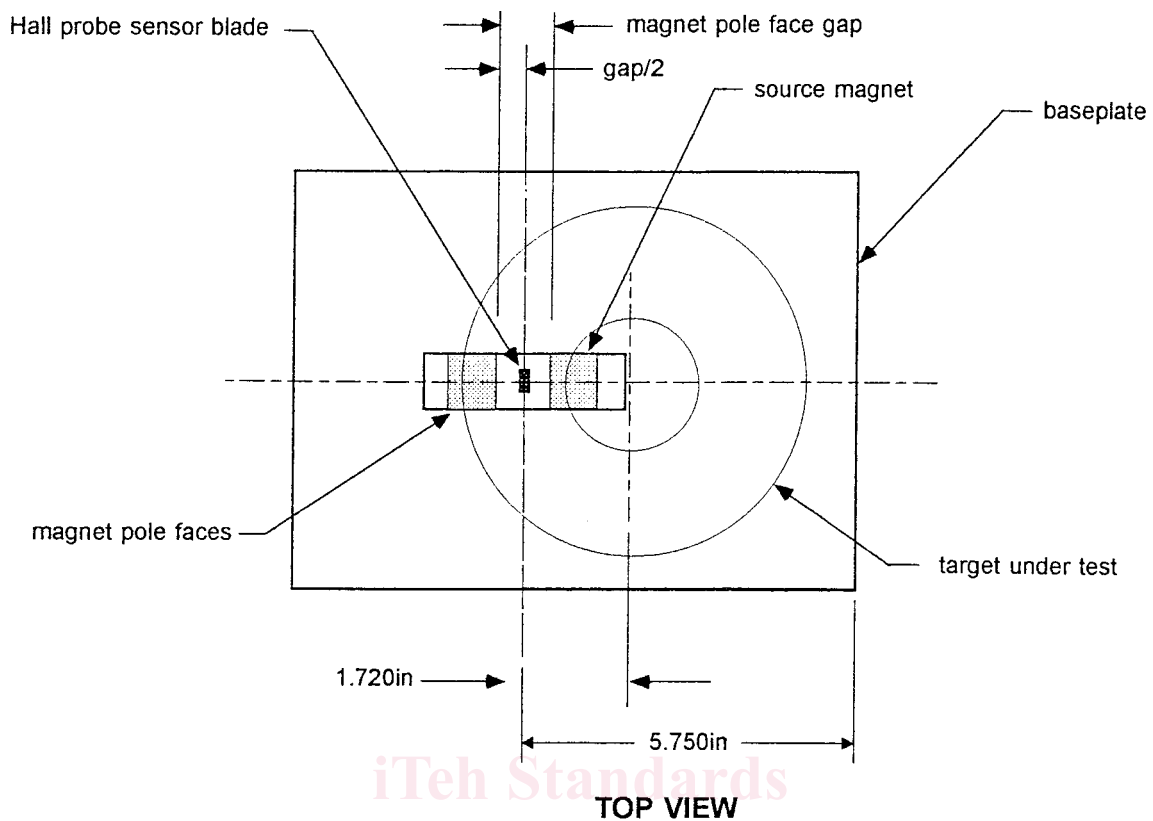

FIG. 1 PTF Test Fixture Setup Schematic Drawing

the target to be tested (with the TFE-fluorocarbon washer in place) will be 0.075 ± 0.025 in. (2.0 ± 0.6 mm). Adjust and tighten the collars on the probe support post to maintain the probe support cross arm at this elevation.

7.9 Swing (rotate) the probe support arm as in 7.6 to maximize the Gaussmeter reading. Record this value.

7.9.1 The maximum dc magnetic field reading, with the Hall probe in the test position but with no sputtering target in place on the fixture's table, is the "reference field" (2.1.2).

7.10 Swing the cross arm to move the probe clear of the target support table.

7.11 Place the TFE-fluorocarbon washer in position on the target support table. The test fixture is now ready for use.

8. Target Preparation

8.1 Activate, zero, and calibrate the screening Gaussmeter (6.3) according to the manufacturer's instructions.

8.2 Use the Gaussmeter to determine that the stray magnetic field in the immediate work area is less than 1 Gauss in strength. Remove sources of excessive stray fields, if necessary.

8.3 Measure the residual magnetic field in the test target by scanning the Gaussmeter probe lightly over the target surface, noting the magnetic intensity component perpendicular to the surface.

8.4 If the residual field exceeds 3 Gauss at any point, treat the test target with the demagnetizer (6.4) until the residual field is reduced to less than 3 Gauss.

9. Procedure

9.1 Identify and mark (for example, with a tab of adhesive tape) a fiducial “zero” position on the outer rim of sputtering target under test.

9.2 Mount the test target on the target table of the PTF fixture. Magnetically condition the target by rotating it counterclockwise on the target support table five complete turns. It is important for reproducible results that the target rotation is always in the same direction, for example, counterclockwise.

NOTE 4—Some magnetic conditioning is usually required to achieve stable, repeatable, PTF values. For most alloys five magnetic cycles (turns) is adequate. In some exceptional cases more cycles may be required (see 9.10).

9.3 By rotating the target counterclockwise, align the zero mark with the Hall probe support post.

9.4 Swing the Hall probe into position over the target using care to ensure that the height of the probe above the target surface is not changed from its original setting (7.8).

9.5 Note the Gaussmeter reading. Swing (rotate) the cross arm to locate the position of maximum magnetic field value. Tighten the nylon friction screw to secure the probe in this position.

9.6 Record the Gaussmeter magnetic field value at this “zero degrees” target orientation.

9.7 Rotate the target $30 \pm 5^\circ$ counterclockwise and record the magnetic field value at the “30°” target orientation.

9.8 Repeat step 9.7 at 60, 90, and 120° target orientations. Record the Gaussmeter readings at each angular setting.

9.8.1 Use caution to avoid bumping and moving the Hall probe while manipulating the target orientation. If the probe is moved it is necessary to start over again, repeating steps 9.5-9.8.

9.9 Without changing the probe height swing (rotate) the cross arm so that the target may be removed without bumping the probe. Remove the target.

9.10 For the first few targets (typically, three test pieces) of a new alloy or new type, verify that the magnetic conditioning (9.2) is adequate by remounting the test target(s) and repeating steps 9.2-9.9. The PTF values measured the second time should agree within 5 % of those determined in the first pass. If the PTF values do not reproduce within the required precision, repeat the magnetic conditioning (9.2) sufficient times that stability is achieved. Future tests of this particular target type will require the more rigorous preconditioning.

NOTE 5—It is sound practice to degauss the test target after the measuring procedure is complete.

10. Computations

10.1 For each of the five individual PTF readings (Section 9), divide by the reference dc magnetic field (7.9) and multiply this quotient by 100 to compute the percentage of the dc magnetic field transmitted through the target (%PTF).

10.2 Review the data to identify the maximum and minimum %PTF’s.

10.3 Average the five %PTF values to determine the average %PTF, (Avg. %PTF).

NOTE 6—Tests conducted in the responsible technical subcommittee indicate that the absolute PTF values determined by this method depend sensitively upon the spacing between the Hall probe tip and the target surface (7.8). The %PTF’s, however, are independent of the clearance between target surface and probe tip within the limits indicated in 7.8.

11. Report

11.1 Report the following information:

11.1.1 For each target tested, report the %PTF value measured at each of the five target orientation angles,

11.1.2 For each target tested, report the average of the five %PTF readings, Avg.%PTF,

11.1.3 Note and report the maximum and minimum of the five %PTF values, and,

11.1.4 Compute and report the range of the five %PTF values, and compute and report the range divided by the average.

12. Precision and Bias

12.1 The responsible technical subcommittee is conducting an interlaboratory comparison to establish the precision and bias of this test method.

13. Keywords

13.1 magnetic data storage media; magnetic field; magnetic sputtering targets; pass through flux; sputtering; sputtering target

APPENDIX
(Nonmandatory Information)
X1. MAGNETIC TEST FIXTURE

X1.1 Application notes for construction of special test fixture (see also Figs. X1.1-X1.11).

| Dash Number | Target Description | Test Fixture Components Required |
|-------------|---|--|
| -1 | Nominal 5.00 in. O.D. by 2.50 in. I.D. by 0.25 in. thick (127.00 mm O.D. by 63.50 mm I.D. by 6.35-mm thick) target to fit MDP 350 sputtering cathode ⁴ | Basic components and fasteners (see Table X1.1), including: -1 target table -1 alignment hub -1 TFE-fluorocarbon washer, and, in addition, 2 each NF10-32 by 3/4 brass flat head screws |

X1.2 For the basic bill of materials for the magnetic test fixture, see Table X1.1.

⁴ The sole source of supply of the sputtering machine MDP 350 known to the committee at this time is Intevac Vacuum System Division, 3550 Bassett Street, Santa Clara, CA 95054. If you are aware of alternative suppliers, please provide this information to ASTM Headquarters. Your comments will receive careful consideration at a meeting of the responsible technical committee,¹ which you may attend.

iTech Standards
(<https://standards.itih.ai>)
Document Preview

[ASTM F2086-01](#)

<https://standards.itih.ai/catalog/standards/sist/57278909-8e81-421e-8467-93d4df9c977a/astm-f2086-01>

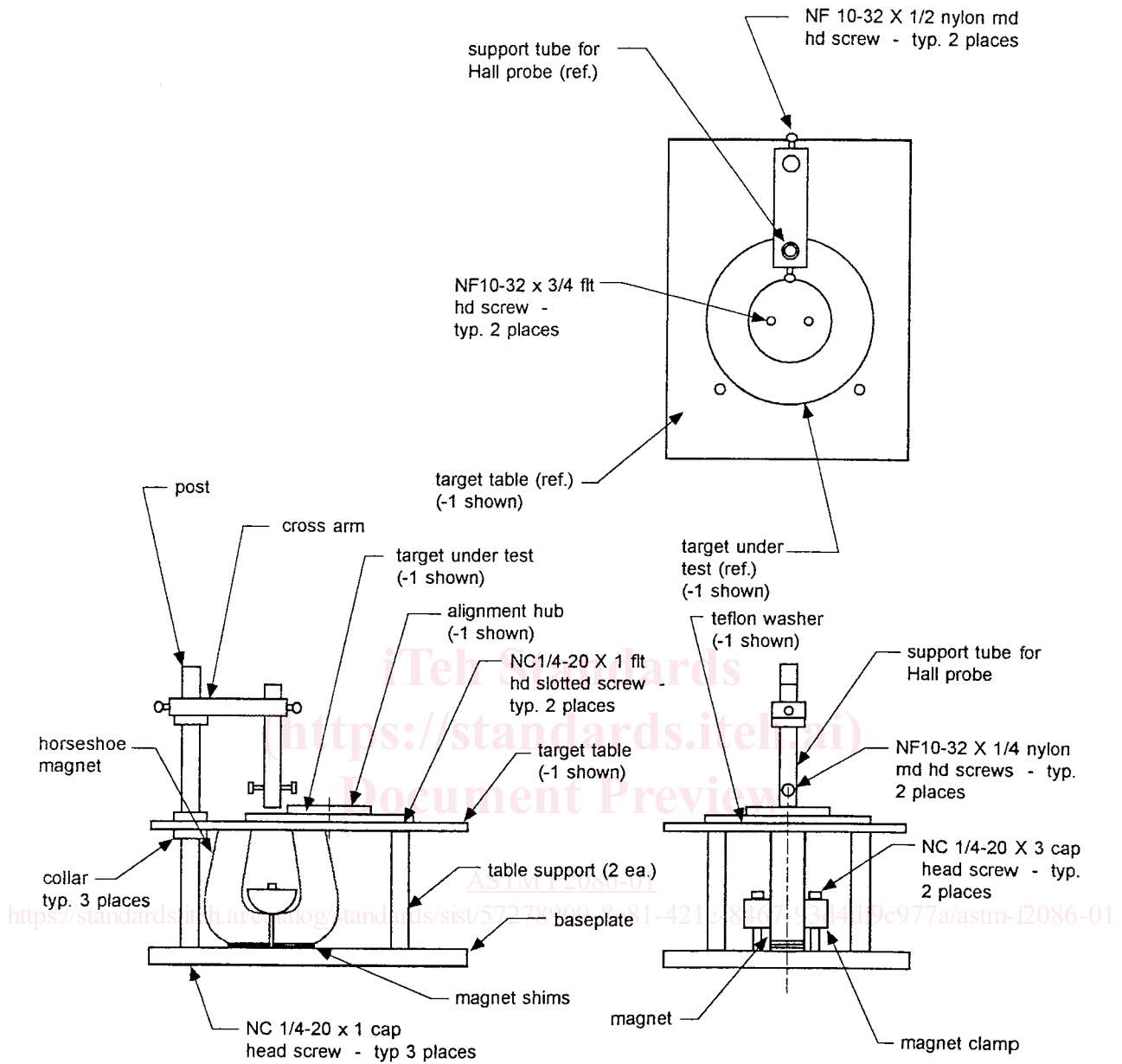

FIG. X1.1 Magnetic Test Fixture - Assy