International Standard



7798

INTERNATIONAL ORGANIZATION FOR STANDARDIZATION • МЕЖДУНАРОДНАЯ ОРГАНИЗАЦИЯ ПО СТАНДАРТИЗАЦИИ • ORGANISATION INTERNATIONALE DE NORMALISATION

Cross-country skis — Determination of fatigue indexes — Cyclic loading test

Skis de fond — Détermination des indices de fatigue — Essai en flexion alternée

First edition — 1984-08-01

iTeh STANDARD PREVIEW
(standards.iteh.ai)

[ISO 7798:1984](#)

<https://standards.iteh.ai/catalog/standards/sist/aedc3de4-217a-4642-84b7-e8c28465d896/iso-7798-1984>

UDC 685.363.2 : 620.178.3

Ref. No. ISO 7798-1984 (E)

Descriptors: sports equipment, skis, cross country skis, tests, fatigue tests, bend tests, cyclic loads, test equipment.

Foreword

ISO (the International Organization for Standardization) is a worldwide federation of national standards bodies (ISO member bodies). The work of developing International Standards is carried out through ISO technical committees. Every member body interested in a subject for which a technical committee has been authorized has the right to be represented on that committee. International organizations, governmental and non-governmental, in liaison with ISO, also take part in the work.

Draft International Standards adopted by the technical committees are circulated to the member bodies for approval before their acceptance as International Standards by the ISO Council.

International Standard ISO 7798 was developed by Technical Committee ISO/TC 83, *Sports and recreational equipment*, and was circulated to the member bodies in September 1983.

It has been approved by the member bodies of the following countries:

| | | |
|---------------------|---------------|-----------------------|
| Austria | Germany, F.R. | South Africa, Rep. of |
| Czechoslovakia | India | Sweden |
| Egypt, Arab Rep. of | Italy | Switzerland |
| Finland | Japan | USSR |
| France | Poland | |

No member body expressed disapproval of the document.

Cross-country skis — Determination of fatigue indexes — Cyclic loading test

1 Scope and field of application

This International Standard specifies a method for the determination of the fatigue indexes of cross-country skis (i.e. the resistance of the skis to changes of bottom camber height or irreversible damage) after a bending test with cyclic loading.

It is applicable to cross-country skis with a nominal length of 160 cm to 215 cm.

2 Reference

ISO 7139, *Cross-country skis — Elastic properties — Laboratory measurement methods*.¹⁾

3 Definitions

For the purpose of this International Standard the following definitions apply:

3.1 original weighted bottom camber h_B : Maximum distance between the bottom surface of the ski in the binding mounting area and a flat and horizontal surface, measured under the influence of the ski's own mass, determined prior to the test.

3.2 final weighted bottom camber h'_B : Maximum distance between the bottom surface of the ski in the binding mounting area and a flat and horizontal surface, measured under the influence of the ski's own mass, determined after the test.

3.3 spring constant of the deflected part of the ski c_F : Ratio of the force F applied midway between two supports, to the corresponding deflection f , when the ski is placed on the supports as shown in figure 4.

$$c_F = \frac{F}{f}$$

3.4 stroke length s : The deflection of the ski during cyclic loading measured from a plane tangent to the supports, mid-way between the two supports.

3.5 frequency, in hertz: The number of deflections of the ski per second.

3.6 recovery time: The time between the end of the test and the measurement of h'_B which is necessary to eliminate temporary changes in bottom camber.

3.7 fatigue index K_h : The percentage change of bottom camber height of the ski after cyclical loading and recovery time.

4 Principle

The ski is subjected to cyclic loading and recovery. The fatigue indexes are determined by calculation of the percentage permanent change in bottom camber height.

5 Apparatus

5.1 Cyclic bending machine

The cyclic bending machine shall be constructed essentially as shown in figure 1. The machine has two supports which are vertically and horizontally adjustable. The support rolls shall have a diameter of approximately 5 cm. The supports shall have spring loaded clamping rolls in order to prevent lifting of the ski.

The driving mechanism consists of a disk fly wheel with adjustable crank pin, a connecting rod and a push rod with clamping fixture. The disk fly wheel shall have sufficient mass and driving power to effect a smooth sinusoidal flexing. The distance between crank pin and rotation axis shall be adjustable in order to be able to adjust the proper stroke length with respect to the spring constant of the deflected part of the ski (see figure 3).

The frequency of the stroke shall be between 2 and 3 Hz. The clamping fixture shall have a pitting joint and jaws with elastic rubber layers, as shown in figure 2, in order to avoid stress concentration at the clamp.

1) At present in the stage of draft.

Dimensions of the rubber layer shall be as follows:

thickness: 4 ± 1 mm

width: 40 mm

hardness: (95 ± 5) Shore A

In addition, a counter shall be fixed to the push rod in order to record the number of cycles.

5.2 Measuring device for bottom camber height

For measuring the weighted bottom camber a flat surface plate and a dial indicator with indicator holder shall be used.

5.3 Measuring device for spring constant of the deflected part of the ski

For measuring the spring constant of the deflected part of the ski, a device as described in ISO 7139 shall be used.

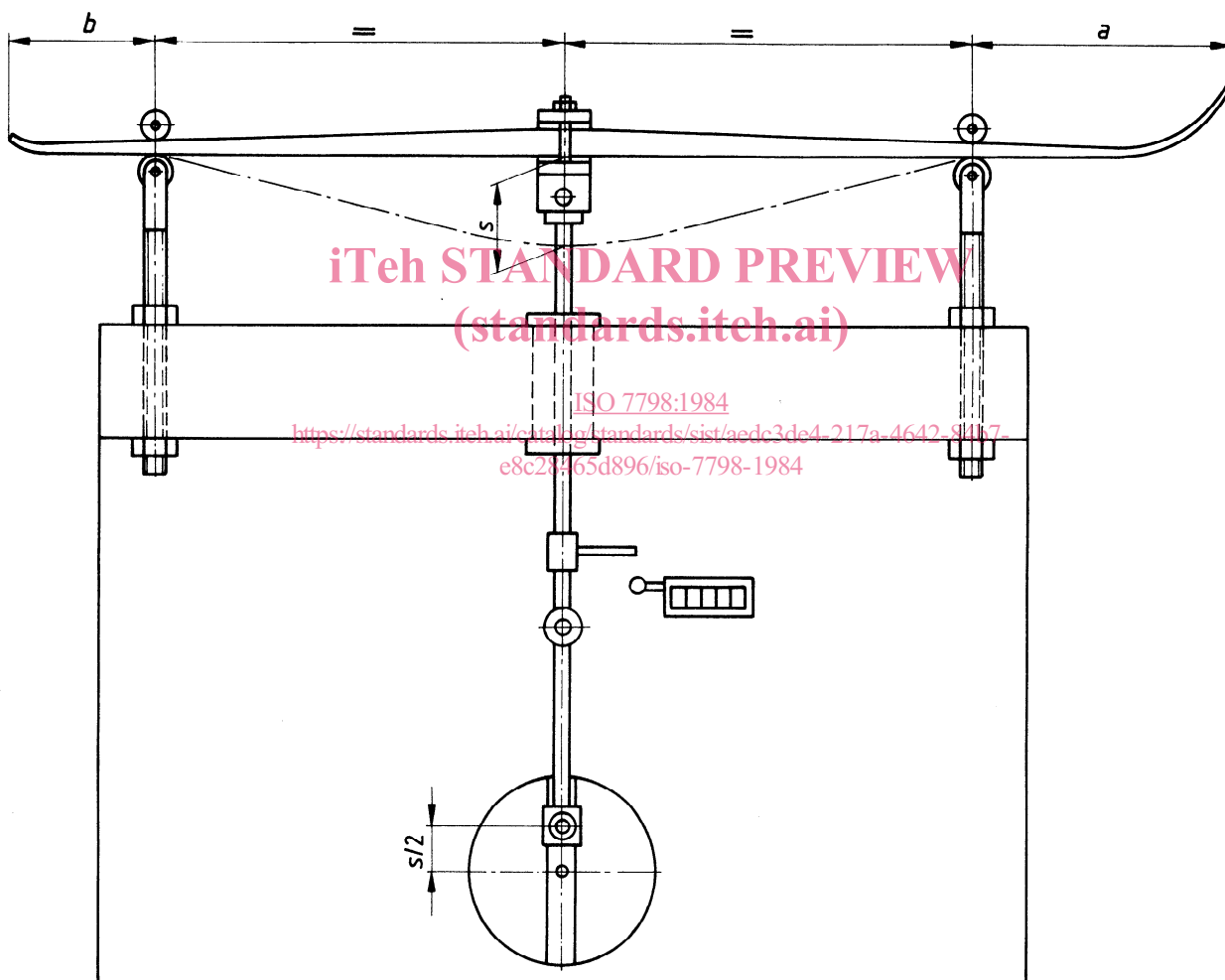
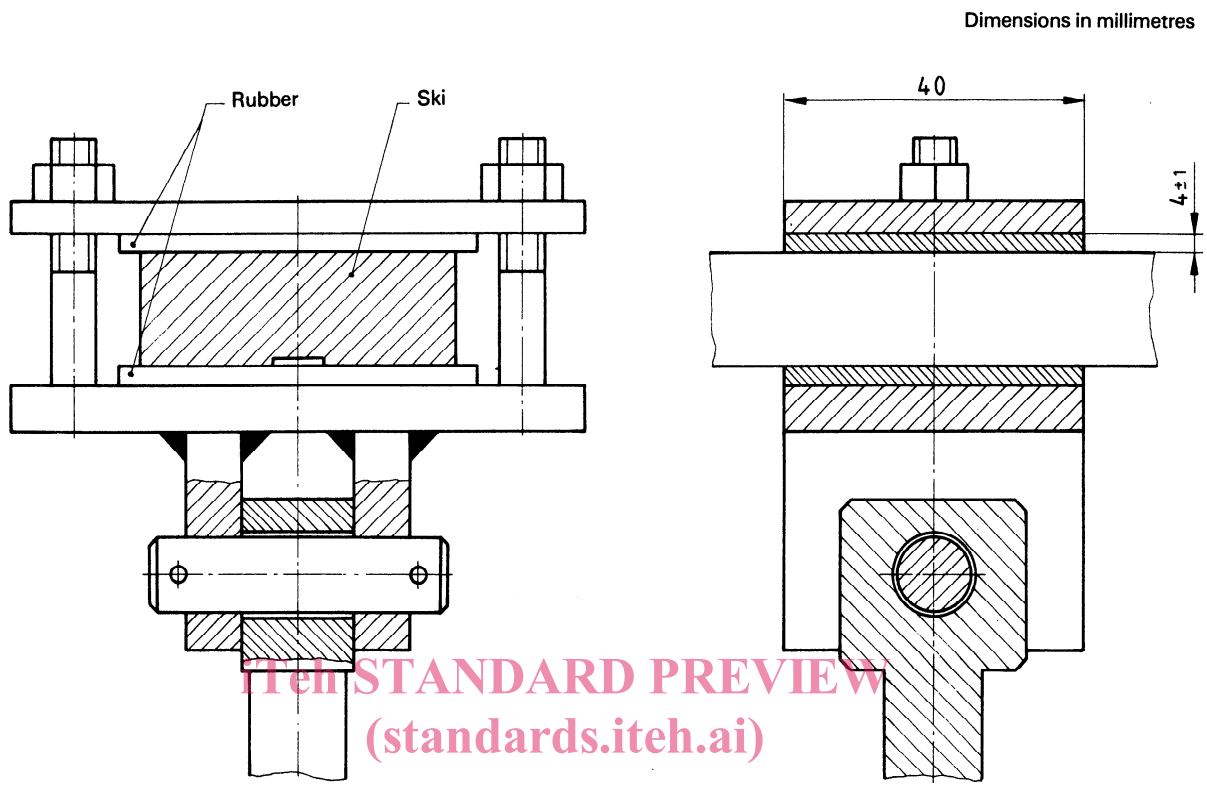

Figure 1 — Cyclic bending machine



ISO 7798:1984
<https://standards.iteh.ai/catalog/standards/sist/aedc3de4-217a-4642-84b7-e8c28465d896/iso-7798-1984>
Figure 2 – Clamping fixture

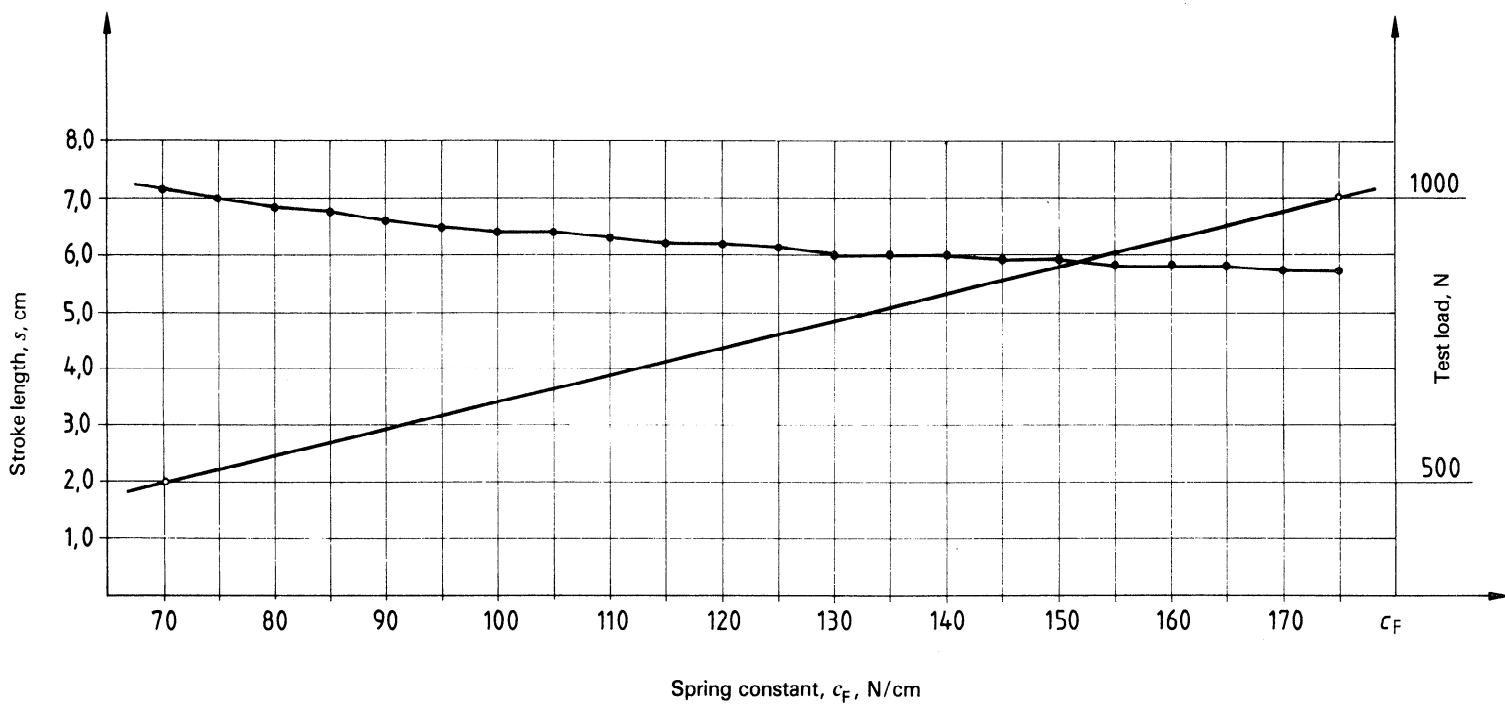

Figure 3 – Diagram for determination of stroke length

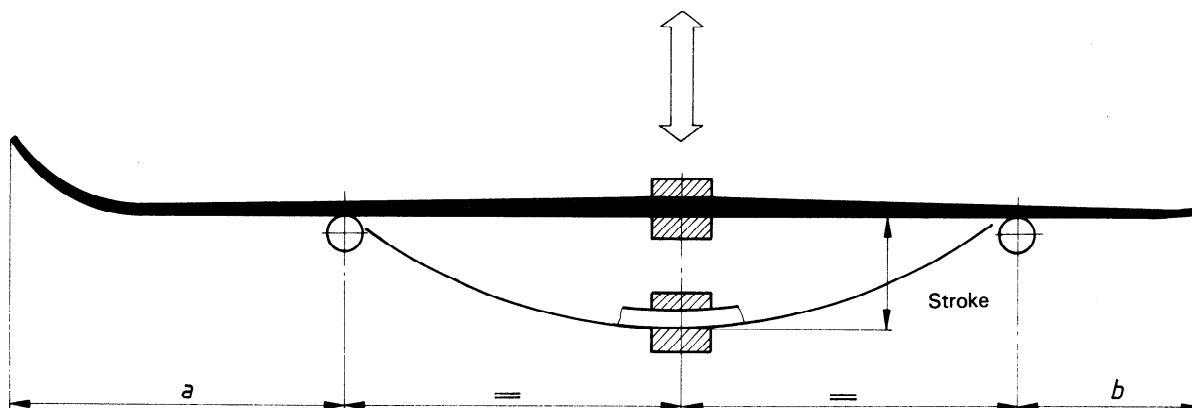

Figure 4 — Support arrangement for determination of spring constant c_F and for fatigue test

Table

Dimensions in millimetres

| Ski length | 1 600 | 1 700 | 1 750 | 1 800 | 1 850 | 1 900 | 1 950 | 2 000 | 2 050 | 2 100 | 2 150 |
|------------|-------|-------|-------|-------|-------|-------|-------|-------|-------|-------|-------|
| <i>a</i> | 370 | 400 | 415 | 430 | 445 | 460 | 475 | 490 | 505 | 520 | 535 |
| <i>b</i> | 250 | 270 | 280 | 290 | 300 | 310 | 320 | 330 | 340 | 350 | 360 |

(standards.iteh.ai)

ISO 7798:1984

6 Test specimens

The test shall be carried out on five skis of the same model-size.

7 Temperatures for conditioning and testing

The fatigue properties of the ski described in this International Standard can be affected by the test temperature to a greater or lesser extent depending on the particular material configuration of the ski. Therefore two versions of test procedure with different test temperatures are specified:

- version A, standard laboratory test: $+20 \pm 2$ °C
- version B, cold chamber test: -20 ± 2 °C

All measurements shall be carried out on a ski conditioned at the test temperature for at least 2 h.

8 Test procedure

8.1 Measurement of original weighted bottom camber, h_B

Measure the height of the original bottom camber h_B after conditioning and prior to the bending by cyclic loading. Mark the measurement point on the top surface of the ski. Press the ski against the flat surface plate. Place the dial indicator at the measurement point on the top surface of the ski and set to zero. Remove the flattening load, and read the bottom camber height from the dial indicator to an accuracy of $\pm 0,03$ mm.

8.2 Measurement of the spring constant of the deflected ski portion, c_F

Determine, from the table of figure 4, the location and the distance of the supports. Place the ski on the supports and load the ski midway between the supports with a load F . Read the deflection f to an accuracy of 0,02 mm. Calculate the spring constant, expressed in newtons per centimetre, using the formula

$$c_F = \frac{F}{f}$$

where

F is the test load, in newtons;

f is the deflection, in centimetres.

8.3 Determination of stroke length, s

For the determination of stroke length use the diagram in figure 3. Find c_F on the abscissa. Read the stroke length s on the ordinate by using the dotted line of the diagram.

NOTE — The stroke length is a function of a defined test load (maximum load at the dead centre of the crank), which increases with stiffness and nominal length of the ski. The test load is 500 N for skis with a spring constant of $c_F = 70$ N/cm (nominal length 160 cm) and increases linearly to 1 000 N for skis with a spring constant of $c_F = 175$ N/cm (nominal length 215 cm). (See the solid line of the diagram in figure 3.) This system is based on the following consideration: the heavier and taller a skier (normally the weight increases with body height), the more a cross-country ski is stressed during skiing, thus it is assumed that a tall skier normally uses a long ski.

8.4 Testing

Place the ski in the bending machine (5.1) as shown in figure 4 and adjust the supports in such a way that the connecting line between the upper points of the lower support rolls and the surface of the clamping jaw (touching the running surface of the ski) is a straight line, when the push rod is in the upper dead centre.

Adjust the stroke length s by shifting the crank pin to its correct position.

Subject the ski to 50 000 loading cycles at a frequency of 2 to 3 Hz.

Remove the ski from the machine and place it against a wall in a vertical and stress-free (relaxed) position. The recovery time for the elimination of temporary deformation is 24 h.

8.5 Measurement of final weighted bottom camber, h'_B

Measure the bottom camber height h'_B at the measurement point as specified in 8.1.

8.6 Assessment of damage

Visually inspect the ski for damage caused by the test (for example cracks or stress marks, delaminations etc.).

9 Expression of results

The fatigue index, K_h , for the bottom camber height of the ski, expressed as a percentage, is given by the formula

$$K_h = \frac{h_B - h'_B}{h_B} \times 100$$

where

h_B is the original weighted bottom camber height, measured in accordance with 8.1;

h'_B is the final weighted bottom camber height, measured in accordance with 8.5.

Calculate the mean value of the five determinations and the standard deviation of the five single measurements.

10 Test report

The test report shall include the following particulars:

- a) reference to this International Standard;
- b) complete identification of the ski (brand, model designation, nominal length and manufacturer's registration number);
- c) test temperature (either version A or B);
- d) fatigue index for the bottom camber height;
- e) damage to the ski caused by the test with exact description;
- f) any deviation from this International Standard with an explanation of the reason for the deviation.

STANDARD PREVIEW
(standards.itech.ai)

ISO 7798:1984

<https://standards.itech.ai/catalog/standards/sist/aedc3de4-217a-4642-84b7->

<https://standards.itech.ai/catalog/standards/sist/aedc3de4-217a-4642-84b7-iso-7798-1984>

iTeh STANDARD PREVIEW
This page intentionally left blank
(standards.iteh.ai)

ISO 7798:1984

<https://standards.iteh.ai/catalog/standards/sist/aedc3de4-217a-4642-84b7-e8c28465d896/iso-7798-1984>