



SLOVENSKI STANDARD
SIST ISO 7801:1996

01-januar-1996

Kovinski materiali - Žica - Preskus z izmeničnim upogibanjem

Metallic materials -- Wire -- Reverse bend test

Matériaux métalliques -- Fils -- Essai de pliage alterné

Ta slovenski standard je istoveten z: ISO 7801:1984

[SIST ISO 7801:1996](https://standards.iteh.ai/catalog/standards/sist/a2a7d627-9a8e-4157-80eb-8fa2380973ff/sist-iso-7801-1996)

<https://standards.iteh.ai/catalog/standards/sist/a2a7d627-9a8e-4157-80eb-8fa2380973ff/sist-iso-7801-1996>

ICS:

77.040.10 Mehansko preskušanje kovin Mechanical testing of metals

SIST ISO 7801:1996

en

iTeh STANDARD PREVIEW
(standards.iteh.ai)

SIST ISO 7801:1996

<https://standards.iteh.ai/catalog/standards/sist/a2a7d627-9a8e-4157-80eb-8fa2380973ff/sist-iso-7801-1996>

International Standard



7801

INTERNATIONAL ORGANIZATION FOR STANDARDIZATION • МЕЖДУНАРОДНАЯ ОРГАНИЗАЦИЯ ПО СТАНДАРТИЗАЦИИ • ORGANISATION INTERNATIONALE DE NORMALISATION

Metallic materials — Wire — Reverse bend test

Matériaux métalliques — Fils — Essai de pliage alterné

First edition — 1984-05-15

iTeh STANDARD PREVIEW
(standards.iteh.ai)

[SIST ISO 7801:1996](#)

<https://standards.iteh.ai/catalog/standards/sist/a2a7d627-9a8e-4157-80eb-8fa2380973ff/sist-iso-7801-1996>

UDC 669-426 : 620.177.6

Ref. No. ISO 7801-1984 (E)

Descriptors : metal products, wire, tests, bend tests, test equipment, test specimens.

Foreword

ISO (the International Organization for Standardization) is a worldwide federation of national standards bodies (ISO member bodies). The work of developing International Standards is carried out through ISO technical committees. Every member body interested in a subject for which a technical committee has been authorized has the right to be represented on that committee. International organizations, governmental and non-governmental, in liaison with ISO, also take part in the work.

Draft International Standards adopted by the technical committees are circulated to the member bodies for approval before their acceptance as International Standards by the ISO Council.

International Standard ISO 7801 was developed by Technical Committee ISO/TC 164, *Mechanical testing of metals*, and was circulated to the member bodies in January 1983.

It has been approved by the member bodies of the following countries:

Australia	Germany, F.R.	Poland
Austria	Hungary	Romania
Bulgaria	Italy	South Africa, Rep. of
Canada	Japan	Spain
China	Korea, Dem. P. Rep. of	Sweden
Czechoslovakia	Mexico	Switzerland
Denmark	Netherlands	USA
France	Norway	USSR

The member body of the following country had expressed disapproval of the document on technical grounds:

United Kingdom

This International Standard ISO 7801 cancels and replaces the International Standards ISO 144-1973 and ISO 2625-1973 of which it constitutes a technical revision.

Metallic materials — Wire — Reverse bend test

iTeh STANDARD PREVIEW (standards.iteh.ai)

1 Scope and field of application

This International Standard specifies the method for determining the ability of metallic wire of diameter or thickness 0,3 to 10 mm inclusive to undergo plastic deformation during reverse bending. The range of diameters or thicknesses for which this International Standard is applicable may be more exactly specified in the relevant product standard.

2 Principle

The reverse bend test consists of repeated bending, through 90° in opposite directions, of a test piece held at one end, each bend being over a cylindrical support of a specified radius.

3 Symbols and designations

Symbols and designations used in reverse bend testing of wires are specified in table 1 and shown in figure 1.

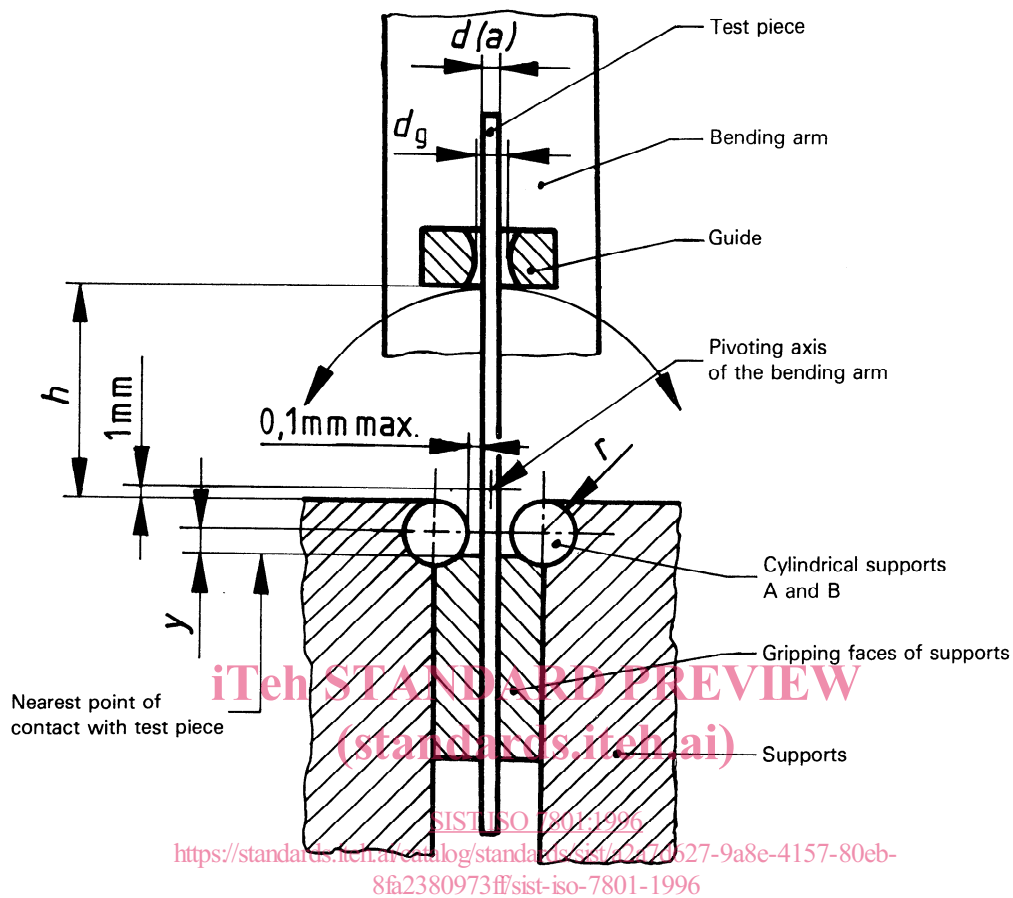

Figure 1

Table 1

Symbol	Designation	Unit
d	Diameter of round wire	mm
a	Minimum thickness of wire of non-circular section capable of being held between parallel grips (see figure 2)	mm
r	Radius of cylindrical supports	mm
h	Distance from the top tangential plane of cylindrical supports to the bottom face of guide	mm
d_g	Diameter of guide hole	mm
y	Distance from a plane, defined by the axes of the cylindrical supports, to the nearest point of contact with the test piece	mm
N_b	Number of reverse bends	—

4 Testing equipment

4.1 General

The testing machine shall be constructed so as to conform with the principles indicated in figure 1 and the essential dimensions given in table 2.

4.2 Cylindrical supports and gripping faces

4.2.1 The cylindrical supports and the gripping faces shall be of sufficient hardness (to provide rigidity and/or resistance to abrasion).

4.2.2 The radius of cylindrical support r shall not differ from its nominal dimension by more than the tolerance given in table 2.

4.2.3 The axes of the cylindrical supports shall be perpendicular to the plane of bend and shall be parallel and in the same plane to within 0,1 mm.

4.2.4 The gripping faces shall project slightly beyond the face of the cylindrical supports to a distance which does not exceed 0,1 mm, as measured by the clearance between the test piece and each cylindrical support on a line joining the centres of curvature.

4.2.5 The top edge of the gripping faces shall be below the centres of curvature of the cylindrical supports by a distance y of 1,5 mm for supports of radius equal to or less than 2,5 mm and by 3 mm for supports of larger radius. (If $r \leq 2,5$ mm, $y = 1,5$ mm; if $r > 2,5$ mm, $y = 3$ mm.)

4.3 Bending arm and guide

4.3.1 The distance of the pivoting axis of the bending arm from the top of the cylindrical supports shall be 1,0 mm for all sizes of supports.

4.3.2 The holes in the guide shall widen out at each end and have a diameter in accordance with table 2.

5 Test piece

5.1 The length of wire to be used as the test piece is to be as straight as possible, but it may exhibit slight curvature in the plane in which it will be bent during the test.

5.2 If straightening is necessary, it shall be done by hand or, if this is not possible, by hammering on a level surface of wood, plastic material or copper using a hammer of a similar material.

5.3 During straightening, the surface of the wire must not be damaged and the test piece must not be subjected to any twisting.

5.4 Wire with a localized sharp curvature shall not be straightened.

6 Procedure

6.1 In general, the test is carried out at ambient temperature between 10 and 35 °C. Tests carried out under controlled conditions shall be made at a temperature of 23 ± 5 °C.

6.2 The radius of the support r , the distance h , and the diameter of the hole d_g shall be selected according to the wire diameter as given in table 2.

6.3 Insert the test piece, with the bending arm vertical, through one of the holes in the guide as indicated in figure 1. Hold the lower end of the test piece between the grips so that

Table 2

Dimensions and tolerances in millimetres

Nominal diameter or thickness of wire $d(a)$	Radius of cylindrical support r	Distance h	Diameter of guide hole ¹⁾ d_g
$0,3 < d(a) < 0,5$	$1,25 \pm 0,05$	15	2,0
$0,5 < d(a) < 0,7$	$1,75 \pm 0,05$	15	2,0
$0,7 < d(a) < 1,0$	$2,5 \pm 0,1$	15	2,0
$1,0 < d(a) < 1,5$	$3,75 \pm 0,1$	20	2,0
$1,5 < d(a) < 2,0$	$5 \pm 0,1$	20	2,0 and 2,5
$2,0 < d(a) < 3,0$	$7,5 \pm 0,1$	25	2,5 and 3,5
$3,0 < d(a) < 4,0$	$10 \pm 0,1$	35	3,5 and 4,5
$4,0 < d(a) < 6,0$	$15 \pm 0,1$	50	4,5 and 7,0
$6,0 < d(a) < 8,0$	$20 \pm 0,1$	75	7,0 and 9,0
$8,0 < d(a) < 10,0$	$25 \pm 0,1$	100	9,0 and 11,0

1) Where appropriate, the smaller diameter of hole is to be used for the smaller nominal diameter of wire (see column 1) and the larger diameter of hole for the larger nominal diameter of wire (also see column 1). For diameters within ranges given in column 1, the appropriate size of hole is to be chosen to ensure free movement of the wire.

ISO 7801-1984 (E)

the test piece is perpendicular to the axes of the cylindrical supports.

NOTE — Non-circular test pieces are to be placed so that the greater dimension is parallel, or approximately parallel, to the gripping faces as shown in figure 2.

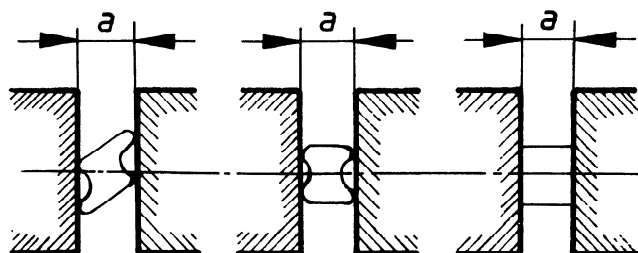

Figure 2

6.4 Bend the test piece through 90° alternately in opposite directions. One bend consists of bending the free end of the test piece through 90° and returning it to its original position. Make the following bend in the opposite direction as shown in figure 3. Do not interrupt the testing between successive bends.

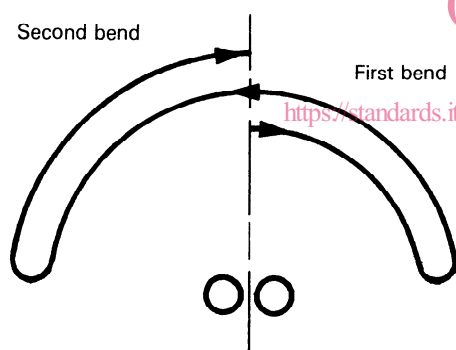

Figure 3

6.5 Bend at a uniform rate without shock, not exceeding one bend per second. If necessary, reduce the rate of bending to ensure that the heat generated does not affect the result of the test.

6.6 To ensure continuous contact between the test piece and the cylindrical supports during the test, some form of constraint may be applied. This may be in the form of a tensile stress not greater than 2 % of the value of the nominal tensile strength, unless otherwise specified in the relevant standard.

6.7 Continue the test until the number of bends specified in the relevant standard is completed, or cracking visible without the use of magnifying aids is seen to occur.

Alternatively, if specified in the relevant standard, continue the test until complete fracture of the test piece occurs.

6.8 The bend during which the failure of test piece occurs shall not be counted into the number of bends N_b .

7 Test report

The test report shall include the following information:

- reference to this International Standard;
- identification of the test piece (e.g. type of the material, cast number, etc.);
- nominal diameter d or minimum thickness a of the test piece;
- details regarding the preparation of the test piece (e.g. straightening);
- test conditions (e.g. radius r of the cylindrical supports, application of tensile stress);
- criterion for ending the test;
- test result.

iTeh STANDARD PREVIEW
This page intentionally left blank
(standards.iteh.ai)

SIST ISO 7801:1996

<https://standards.iteh.ai/catalog/standards/sist/a2a7d627-9a8e-4157-80eb-8fa2380973ff/sist-iso-7801-1996>