

TECHNICAL SPECIFICATION



**Recommendations for small renewable energy and hybrid systems for rural electrification –
Part 9-2: Microgrids**

<https://standards.iteh.ai>
Document Preview

IEC TS 62257-9-2:2006

<https://standards.iteh.ai/catalog/standards/iec/4d796818-cb62-44a0-994e-690bdc3cdb75/iec-ts-62257-9-2-2006>



THIS PUBLICATION IS COPYRIGHT PROTECTED

Copyright © 2006 IEC, Geneva, Switzerland

All rights reserved. Unless otherwise specified, no part of this publication may be reproduced or utilized in any form or by any means, electronic or mechanical, including photocopying and microfilm, without permission in writing from either IEC or IEC's member National Committee in the country of the requester.

If you have any questions about IEC copyright or have an enquiry about obtaining additional rights to this publication, please contact the address below or your local IEC member National Committee for further information.

Droits de reproduction réservés. Sauf indication contraire, aucune partie de cette publication ne peut être reproduite ni utilisée sous quelque forme que ce soit et par aucun procédé, électronique ou mécanique, y compris la photocopie et les microfilms, sans l'accord écrit de la CEI ou du Comité national de la CEI du pays du demandeur.

Si vous avez des questions sur le copyright de la CEI ou si vous désirez obtenir des droits supplémentaires sur cette publication, utilisez les coordonnées ci-après ou contactez le Comité national de la CEI de votre pays de résidence.

IEC Central Office
3, rue de Varembe
CH-1211 Geneva 20
Switzerland
Email: inmail@iec.ch
Web: www.iec.ch

About IEC publications

The technical content of IEC publications is kept under constant review by the IEC. Please make sure that you have the latest edition, a corrigenda or an amendment might have been published.

- Catalogue of IEC publications: www.iec.ch/searchpub

The IEC on-line Catalogue enables you to search by a variety of criteria (reference number, text, technical committee,...). It also gives information on projects, withdrawn and replaced publications.

- IEC Just Published: www.iec.ch/online_news/justpub

Stay up to date on all new IEC publications. Just Published details twice a month all new publications released. Available on-line and also by email.

- Electropedia: www.electropedia.org

The world's leading online dictionary of electronic and electrical terms containing more than 20 000 terms and definitions in English and French, with equivalent terms in additional languages. Also known as the International Electrotechnical Vocabulary online.

- Customer Service Centre: www.iec.ch/webstore/custserv

If you wish to give us your feedback on this publication or need further assistance, please visit the Customer Service Centre FAQ or contact us:

Email: csc@iec.ch
Tel.: +41 22 919 02 11
Fax: +41 22 919 03 00

TECHNICAL SPECIFICATION



**Recommendations for small renewable energy and hybrid systems for rural
electrification –
Part 9-2: Microgrids**

IEC TS 62257-9-2:2006

<https://standards.iteh.ai/catalog/standards/iec/4d726818-cb62-44a0-994e-690bdc3cdb75/iec-ts-62257-9-2-2006>

INTERNATIONAL
ELECTROTECHNICAL
COMMISSION

PRICE CODE **XA**

ICS 27.160; 27.180

ISBN 2-8318-8863-8

CONTENTS

FOREWORD.....	4
INTRODUCTION.....	6
1 Scope.....	7
2 Normative reference.....	7
3 Terms and definitions.....	7
4 General.....	9
4.1 Limits of a microgrid.....	9
4.2 Voltage drops.....	9
4.3 Composition of a microgrid.....	9
5 Protection against electric shocks.....	11
6 Protection against overcurrents.....	11
7 Selection and erection of equipment.....	11
7.1 Equipment installation.....	11
7.2 Operational conditions and external influences.....	11
7.3 Characteristics of lines.....	13
7.4 Cables.....	14
7.5 Poles.....	14
7.6 Cable anchorage.....	17
7.7 Connections and accessories.....	17
7.8 Where poles are used for other purposes.....	19
7.9 Isolation and switching.....	19
7.10 Earthing arrangement, protective conductors and protective bonding conductors.....	20
8 Verification and acceptance.....	22
8.1 General.....	22
8.2 Supervision of works.....	22
8.3 Verification before commissioning (on site acceptance).....	22
8.4 Operation tests.....	23
Annex A (informative) Characteristics of cables.....	24
Annex B (informative) Maximum circuit length.....	26
Figure 1 – Microgrid limits.....	9
Figure 2 – Microgrid consisting of a single-phase feeder.....	10
Figure 3 – Three phase system output, single phase distribution or three phase service provided where needed.....	10
Figure 4 – Three phase system output, single phase distribution.....	11
Figure 5 – Diagram showing installation of twinned wooden poles forming an angle.....	16
Figure 6 – Examples of different pole arrangements.....	16
Figure 7 – Example of an overhead line.....	16
Figure 8 – Connection mode diagram.....	19
Figure 9 – Microgrid earthing scheme.....	21

Table 1 – Maximum values of voltage drops.....	9
Table 2 – Fuse ratings for protection from short-circuiting in 230 V a.c. microgrids (overhead lines).....	20
Table 3 – Fuse ratings for protection from short-circuiting in 120 V a.c. microgrids (overhead lines).....	20
Table 4 – Circuit breaker ratings for protection from short-circuiting in microgrids (overhead lines).....	20
Table 5 – Characteristics of earthing components.....	22
Table A.1 – Example of characteristics of grid conductors for overhead lines (insulated twisted conductors without carrier neutral).....	24

iTech Standards
(<https://standards.iteh.ai>)
Document Preview

IEC TS 62257-9-2:2006

<https://standards.iteh.ai/catalog/standards/iec/4d726818-cb62-44a0-994e-690bdc3cdb75/iec-ts-62257-9-2-2006>

INTERNATIONAL ELECTROTECHNICAL COMMISSION

**RECOMMENDATIONS FOR SMALL RENEWABLE ENERGY
AND HYBRID SYSTEMS FOR RURAL ELECTRIFICATION****Part 9-2: Microgrids**

FOREWORD

- 1) The International Electrotechnical Commission (IEC) is a worldwide organization for standardization comprising all national electrotechnical committees (IEC National Committees). The object of IEC is to promote international co-operation on all questions concerning standardization in the electrical and electronic fields. To this end and in addition to other activities, IEC publishes International Standards, Technical Specifications, Technical Reports, Publicly Available Specifications (PAS) and Guides (hereafter referred to as "IEC Publication(s)"). Their preparation is entrusted to technical committees; any IEC National Committee interested in the subject dealt with may participate in this preparatory work. International, governmental and non-governmental organizations liaising with the IEC also participate in this preparation. IEC collaborates closely with the International Organization for Standardization (ISO) in accordance with conditions determined by agreement between the two organizations.
- 2) The formal decisions or agreements of IEC on technical matters express, as nearly as possible, an international consensus of opinion on the relevant subjects since each technical committee has representation from all interested IEC National Committees.
- 3) IEC Publications have the form of recommendations for international use and are accepted by IEC National Committees in that sense. While all reasonable efforts are made to ensure that the technical content of IEC Publications is accurate, IEC cannot be held responsible for the way in which they are used or for any misinterpretation by any end user.
- 4) In order to promote international uniformity, IEC National Committees undertake to apply IEC Publications transparently to the maximum extent possible in their national and regional publications. Any divergence between any IEC Publication and the corresponding national or regional publication shall be clearly indicated in the latter.
- 5) IEC provides no marking procedure to indicate its approval and cannot be rendered responsible for any equipment declared to be in conformity with an IEC Publication.
- 6) All users should ensure that they have the latest edition of this publication.
- 7) No liability shall attach to IEC or its directors, employees, servants or agents including individual experts and members of its technical committees and IEC National Committees for any personal injury, property damage or other damage of any nature whatsoever, whether direct or indirect, or for costs (including legal fees) and expenses arising out of the publication, use of, or reliance upon, this IEC Publication or any other IEC Publications.
- 8) Attention is drawn to the Normative references cited in this publication. Use of the referenced publications is indispensable for the correct application of this publication.
- 9) Attention is drawn to the possibility that some of the elements of this IEC Publication may be the subject of patent rights. IEC shall not be held responsible for identifying any or all such patent rights.

The main task of IEC technical committees is to prepare International Standards. In exceptional circumstances, a technical committee may propose the publication of a technical specification when

- the required support cannot be obtained for the publication of an International Standard, despite repeated efforts, or
- The subject is still under technical development or where, for any other reason, there is the future but no immediate possibility of an agreement on an International Standard.

Technical specifications are subject to review within three years of publication to decide whether they can be transformed into International Standards.

IEC 62257-9-2, which is a technical specification, has been prepared by IEC technical committee 82: Solar photovoltaic energy systems.

This part of IEC 62257-9 is based on IEC/PAS 62111 (1999); it cancels and replaces the relevant parts of IEC/PAS 62111.

This part of IEC 62257-9 is to be used in conjunction with the IEC 62257 series.

The text of this technical specification is based on the following documents:

Enquiry draft	Report on voting
82/412/DTS	82/443/RVC

Full information on the voting for the approval of this technical specification can be found in the report on voting indicated in the above table.

This publication has been drafted in accordance with the ISO/IEC Directives, Part 2.

A list of all parts of the IEC 62257 series, under the general title *Recommendations for small renewable energy and hybrid systems for rural electrification*, can be found on the IEC website.

The committee has decided that the contents of this publication will remain unchanged until the maintenance result date indicated on the IEC web site under "<http://webstore.iec.ch>" in the data related to the specific publication. At this date, the publication will be

- transformed into an international standard;
- reconfirmed;
- withdrawn;
- replaced by a revised edition, or
- amended.

A bilingual version of this publication may be issued at a later date.

IMPORTANT – The “colour inside” logo on the cover page of this publication indicates that it contains colours which are considered to be useful for the correct understanding of its contents. Users should therefore print this publication using a colour printer.

INTRODUCTION

The IEC 62257 series intends to provide to different players involved in rural electrification projects (such as project implementers, project contractors, project supervisors, installers, etc.) documents for the setting up of renewable energy and hybrid systems with a.c. nominal voltage below 500 V, d.c. nominal voltage below 750 V and nominal power below 100 kVA.

These documents are recommendations:

- to choose the right system for the right place,
- to design the system,
- to operate and maintain the system.

These documents are focused only on rural electrification concentrating on but not specific to developing countries. They should not be considered as all inclusive to rural electrification. The documents try to promote the use of renewable energies in rural electrification; they do not deal with clean mechanisms developments at this time (CO₂ emission, carbon credit, etc.). Further developments in this field could be introduced in future steps.

This consistent set of documents is best considered as a whole with different parts corresponding to items for safety, sustainability of systems and at the lowest life cycle cost as possible. One of the main objectives is to provide the minimum sufficient requirements, relevant to the field of application that is: small renewable energy and hybrid off-grid systems.

Decentralized Rural Electrification Systems (DRES) are designed to supply electric power for sites which are not connected to a large interconnected system, or a national grid, in order to meet basic needs.

The majority of these sites are:

- isolated dwellings,
- village houses,
- community services (public lighting, pumping, health centres, places of worship or cultural activities, administrative buildings, etc.),
- economic activities (workshops, microindustry, etc.).

The DRE systems fall into three categories:

- process electrification systems (for example for pumping),
- individual electrification systems (IES) for single users,
- collective electrification systems (CES) for multiple users.

Process or individual electrification systems exclusively consist of two subsystems:

- an electric energy generation subsystem,
- the user's electrical installation.

Collective electrification systems, however, consist of three subsystems:

- an electric energy generation subsystem,
- a distribution subsystem, also called microgrid,
- user's electrical installations including interface equipment between the installations and the microgrid.

RECOMMENDATIONS FOR SMALL RENEWABLE ENERGY AND HYBRID SYSTEMS FOR RURAL ELECTRIFICATION

Part 9-2: Microgrids

1 Scope

The purpose this part of IEC 62257-9 is to specify the general requirements for the design and the implementation of microgrids used in decentralized rural electrification to ensure the safety of persons and property and their satisfactory operation according to the scheduled use.

This part of IEC 62257-9 applies to microgrids for decentralized rural electrification purposes. The microgrids covered by this part of IEC 62257-9 are low voltage a.c., three-phase or single-phase, with rated capacity less than or equal to 100 kVA. They are powered by a single micropowerplant and do not include voltage transformation.

The low-voltage levels covered under this part of IEC 62257-9 are the 230 V 1-Ø/400 V 3-Ø systems, 220 V 1-Ø/380 V 3-Ø, the 120 V 1-Ø/208 V 3-Ø, 60 Hz or 50 Hz systems.

This part of IEC 62257-9 specifies microgrids made of overhead lines because of technical and economical reasons in the context of decentralized rural electrification. In particular cases, underground cables can be used.

The requirements cover microgrids with radial architecture.

2 Normative reference

The following referenced documents are indispensable for the application of this document. For dated references, only the edition cited applies. For undated references, the latest edition of the referenced document (including any amendments) applies.

IEC 62257 (all parts), *Recommendations for small renewable energy and hybrid systems for rural electrification*

IEC 60439 (all parts), *Low-voltage switchgear and controlgear assemblies*

3 Terms and definitions

For the purposes of this document, the following terms and definitions apply.

3.1

carrier (messenger)

wire or a rope, the primary function of which is to support the cable in aerial installations, which may be separate from or integral with the cable it supports

3.2

block

part of a line between two consecutive stoppage poles

3.3

earth

conductive mass of the earth, whose electric potential at any point is conventionally taken as equal to zero

3.4

microgrid

subsystem of a DRES intended for power distribution of which the capacity does not exceed 100 kVA

NOTE The prefix «micro» is intended to express the low level of transmitting capacity.

3.5

micropowerplant

subsystem of a DRES for power generation up to 100 kVA

NOTE The prefix «micro» is intended to express the low power level generated (from a few kVA to a few tens of kVA).

3.6

protective conductor

identification: PE

conductor provided for purposes of safety, for example protection against electric shock

[IEV 195-02-09]

3.7

PEN conductor

conductor combining the functions of both a protective earthing conductor and a neutral conductor

[IEV 195-02-12]

3.8

power line

overhead or underground line installed to convey electrical energy for any purpose other than communication

3.9

section of an overhead line

part of a line between two tension poles

NOTE A section generally includes several spans.

3.10

selectivity (or protection coordination)

ability of a protection to identify the faulty section and/or phase(s) of a power system

[IEV 448-11-06]

3.11

service connection line

conductors between the supplier's mains and the customer's installation

NOTE In the case of an overhead service connection, this means the conductor between a supply-line pole and the customer's installation.

3.12

span

part of a line between two consecutive poles

3.13**stay**

steel wire, rope or rod, working under tension, that connects a point of a support to a separate anchor

4 General**4.1 Limits of a microgrid**

The microgrid is defined between the output terminals of the isolating device of the micropowerplant and the input terminals of the user's interface as illustrated in Figure 1.

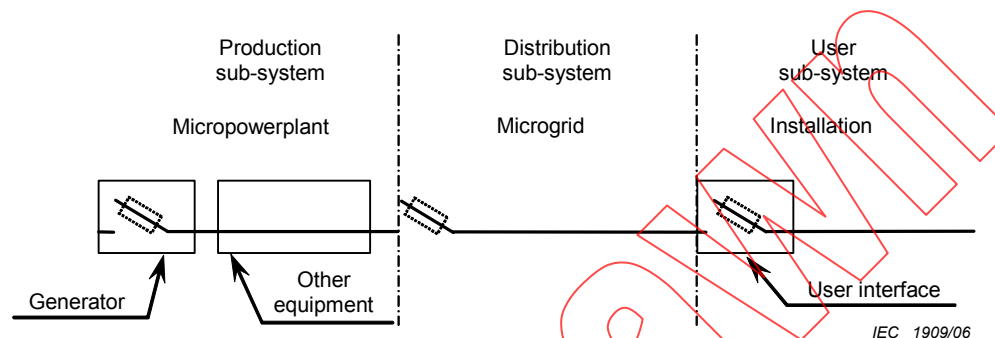

Figure 1 – Microgrid limits

4.2 Voltage drops

The maximum values of the voltage drops in the microgrid shall not exceed the values indicated in Table 1.

Table 1 – Maximum values of voltage drops

Microgrid	Voltage drop
Main line	6 %
Individual service connection line	1 %

4.3 Composition of a microgrid

Three microgrid schemes are specified in this part of IEC 62257-9 depending on the maximum active power value required and the topography of the areas to be served.

- **single-phase power system output:** one single-phase feeder with multiple single phase distribution (see Figure 2).

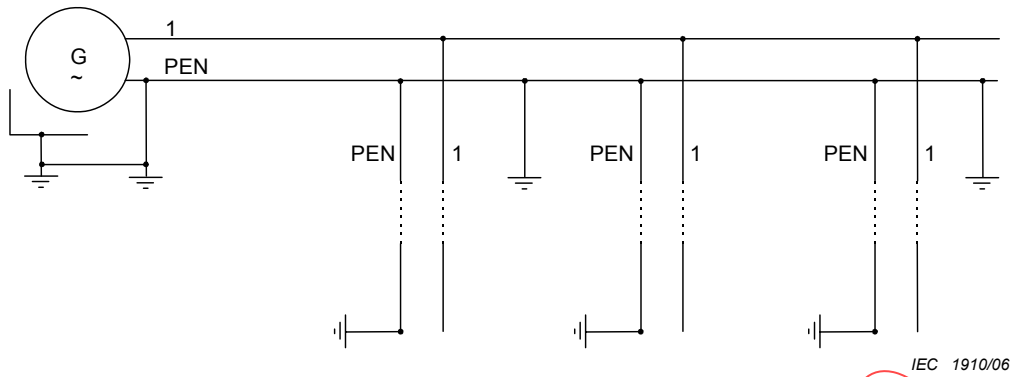

Figure 2 – Microgrid consisting of a single-phase feeder

NOTE A community could be served by multiple single phase distribution driven by different single phase generators.

- **three phase system output:** depending on the power needs of the customers, the layout of the area to be served and the cost, two different distribution architectures can be used, as shown in Figure 3 and Figure 4.
 - 1) Case 1: Three-phase power system output; one three-phase feeder with three phase or single phase distribution.

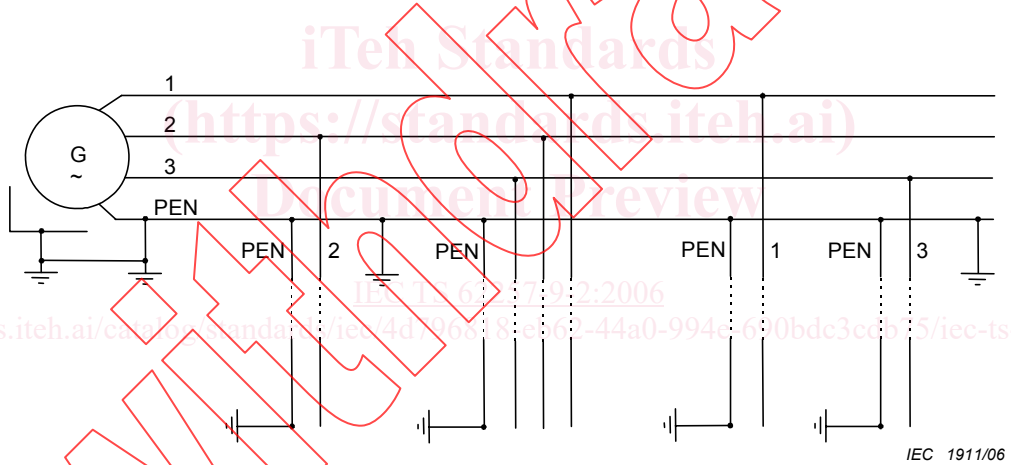

Figure 3 – Three phase system output, single phase distribution or three phase service provided where needed

- 2) Case 2: Three-phase power system output; single phase distribution is used throughout the community.

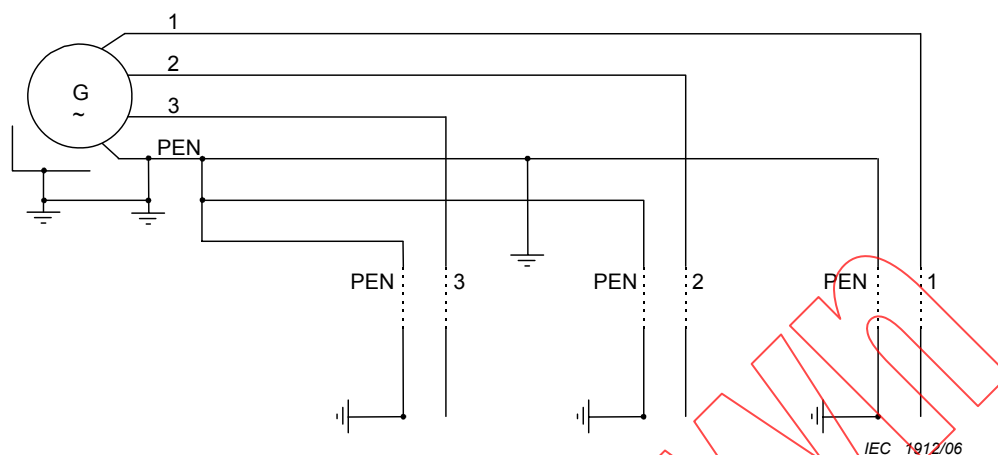

Figure 4 – Three phase system output, single phase distribution

5 Protection against electric shocks

The microgrid shall be designed as a TN-C system (refer to IEC 62257-5).

6 Protection against overcurrents

The microgrid shall be provided with a device to protect against overcurrent. It shall be placed at the interface with the micropowerplant

The characteristics of the device shall ensure that, at any point, negligible impedance faults between phase conductor and protection conductor or earth will cause automatic disconnection within a period of time of 0,4 s.

Special attention shall be paid to the selectivity with respect to the overcurrent protective device of the user's installation. The selectivity between protective devices in series should ensure that any faulty section is interrupted.

7 Selection and erection of equipment

7.1 Equipment installation

All switch gear and control equipment shall be installed in cabinets or cases which allow access only to authorized personnel. The cabinets shall comply with the IEC 60439 series.

7.2 Operational conditions and external influences

7.2.1 Ambient temperature

The conductors shall be chosen and installed so as to suit the highest local ambient temperature.

The microgrid sections, including conductors and accessories, shall be installed within the temperature limits specified by the product manufacturers and according to the manufacturers instructions (see cable characteristics in Annex A).

7.2.2 Sources of heat

To avoid the effects of heat emitted by outside sources, the following methods or equally efficient methods may be used to protect the cables:

- sufficient distance from sources of heat,
- protection screen,
- choice of line to allow for detrimental effects that may occur, local strengthening or change of insulating material.

NOTE The heat given off by outside sources may be transmitted by convection, conduction or radiation.

7.2.3 Presence of water

The microgrid conductors and equipment shall be selected and installed to avoid damage by water. Special precautions may be necessary for microgrid sections frequently exposed to water or are liable to be immersed.

7.2.4 Risk of penetration of solid bodies

The microgrid conductors and equipment shall be selected and installed to minimize hazards caused by the penetration of solid bodies. The cables and equipment shall ensure that the IP protection degree is appropriate to the chosen location.

For locations where large quantities of dust appear, additional precautions shall be taken to prevent the buildup of substances in quantities that are liable to affect the dissipation of heat from the conductors.

7.2.5 Corrosive or polluting substance presence

When there is a possibility of corrosive substances occurring, including water, which are liable to cause degradation or corrosion, all the parts of the line shall be suitably protected or manufactured from material that resists such substances.

Different materials that may form electrolytic couples shall not be brought into contact with the conductors unless special steps are taken to avoid the consequences of such contacts.

The materials that may cause mutual individual degradation or hazardous degradation shall not be allowed to come into contact with other materials.

7.2.6 Mechanical requirements

For fixed installations in which medium, high or very high impact may occur, protection shall be performed by any of the following arrangements:

- mechanical characteristics of the cables,
- chosen location,
- provision of complementary local or general mechanical protection,

or by any combination thereof.

The requirements provided in this part of IEC 62257-9 allow the project implementer to erect microgrids matching the needs of consumers in rural areas and also matching normal climatic conditions. If harsh conditions are expected, specific design studies shall be performed.