

INTERNATIONAL STANDARD

**Application integration at electric utilities – System interfaces for distribution management –
Part 13: CIM RDF Model exchange format for distribution**

IEC 61968-13:2008

<https://standards.iteh.ai/catalog/standards/iec/7/7e6d88-d48a-4c99-8b82-748809d8d985/iec-61968-13-2008>

WITHDRAWN



THIS PUBLICATION IS COPYRIGHT PROTECTED

Copyright © 2008 IEC, Geneva, Switzerland

All rights reserved. Unless otherwise specified, no part of this publication may be reproduced or utilized in any form or by any means, electronic or mechanical, including photocopying and microfilm, without permission in writing from either IEC or IEC's member National Committee in the country of the requester.

If you have any questions about IEC copyright or have an enquiry about obtaining additional rights to this publication, please contact the address below or your local IEC member National Committee for further information.

IEC Central Office
3, rue de Varembe
CH-1211 Geneva 20
Switzerland
Email: inmail@iec.ch
Web: www.iec.ch

About the IEC

The International Electrotechnical Commission (IEC) is the leading global organization that prepares and publishes International Standards for all electrical, electronic and related technologies.

About IEC publications

The technical content of IEC publications is kept under constant review by the IEC. Please make sure that you have the latest edition, a corrigenda or an amendment might have been published.

- Catalogue of IEC publications: www.iec.ch/searchpub

The IEC on-line Catalogue enables you to search by a variety of criteria (reference number, text, technical committee,...). It also gives information on projects, withdrawn and replaced publications.

- IEC Just Published: www.iec.ch/online_news/justpub

Stay up to date on all new IEC publications. Just Published details twice a month all new publications released. Available on-line and also by email.

- Electropedia: www.electropedia.org

The world's leading online dictionary of electronic and electrical terms containing more than 20 000 terms and definitions in English and French, with equivalent terms in additional languages. Also known as the International Electrotechnical Vocabulary online.

- Customer Service Centre: www.iec.ch/webstore/custserv

If you wish to give us your feedback on this publication or need further assistance, please visit the Customer Service Centre FAQ or contact us:

Email: csc@iec.ch

Tel.: +41 22 919 02 11

Fax: +41 22 919 03 00

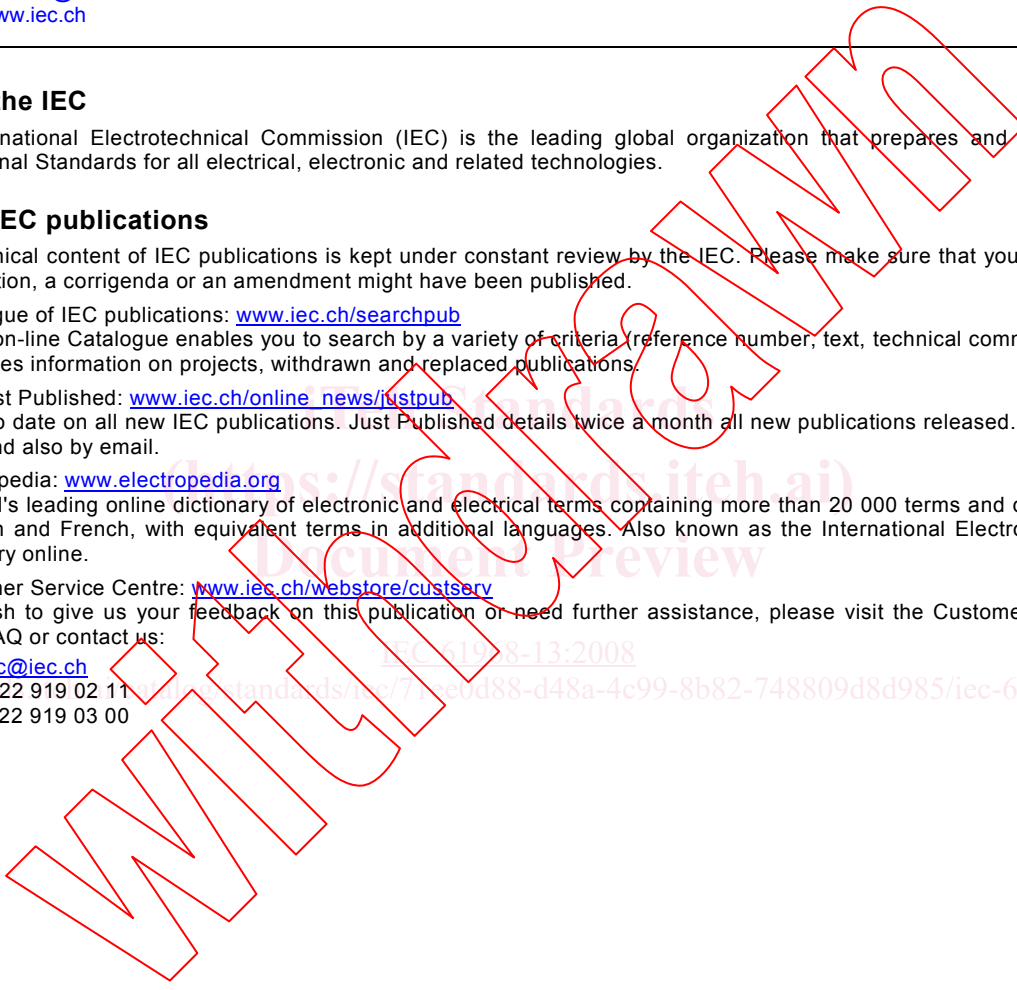

https://standards.iteh.ai/catalog/standards/iec/71e6bd88-d48a-4c99-8b82-748809d8d985/iec-61968-13-2008

INTERNATIONAL STANDARD

**Application integration at electric utilities – System interfaces for distribution management –
Part 13: CIM RDF Model exchange format for distribution**

WITHDRAWN

INTERNATIONAL
ELECTROTECHNICAL
COMMISSION

PRICE CODE **XA**

CONTENTS

FOREWORD.....	4
INTRODUCTION.....	6
1 Scope.....	7
2 Normative references.....	8
3 Future standards documents related to this part.....	9
4 CIM RDF describing distribution networks.....	9
5 Issues related to partial-phase devices modeling.....	10
5.1 General.....	10
5.2 Impedances of unbalanced and partial phase devices.....	10
5.3 Switches.....	10
5.4 Partial phase continuity in radial networks.....	10
6 CIM classes used and corresponding RDF.....	11
6.1 General.....	11
6.2 BaseVoltage and VoltageLevel.....	11
6.3 Containment hierarchy roots.....	12
6.4 HV/MV substation.....	12
6.5 MV/MV substation.....	12
6.6 MV/LV substation.....	13
6.7 Junction.....	13
6.8 Switch.....	14
6.9 Bay.....	14
6.10 BusbarSection.....	15
6.11 PowerTransformer.....	16
6.12 MV/MV transformer.....	17
6.13 Line.....	17
6.14 ACLineSegment.....	19
6.15 WireArrangement.....	19
6.16 Compensator.....	21
6.17 StaticVarCompensator.....	21
6.18 EquivalentLoad.....	22
6.19 Using CustomerLoad, GeneratingUnit and SynchronousMachine to model Distributed Energy Resource.....	23
6.20 GeneratingUnit.....	24
6.21 SynchronousMachine.....	24
6.22 HostControlArea.....	25
6.23 SubControlArea.....	25
7 Adequation between IEC 61968-3 (CDPSM) and IEC 61968-4.....	25
8 Adequation between CDPSM and CPSM.....	26
Annex A (informative) CIM XML Document from Langdale.....	27
Annex B (informative) Comparison between CIM RDF and CIM XSD (ISO ITC Working Group Architecture).....	30
Annex C (informative) Key discussion points on CIM RDF and CIM XSD (ISO ITC Working Group Architecture).....	32
Annex D (informative) Conclusions and recommendations (ISO ITC Working Group Architecture).....	33

Annex E (informative) Example of a European distribution network described through CIM RDF.....	34
Annex F (informative) Example of a North American distribution network.....	42
Annex G (informative) Comparison between CDPSM and CPSM.....	44
Bibliography.....	58
Figure 1 – XML-based DMS network data configuration.....	8
Figure 2 – Connectivity of BusbarSection.....	15
Figure E.1 – European distribution network example.....	35
Figure F.1 – North American distribution network example.....	43
Table 1 – Header of NetworkDataSet message type.....	25
Table 2 – Message Payload of NetworkDataSet message type.....	26

iTech Standards
(<https://standards.iteh.ai>)
Document Preview

IEC 61968-13:2008

<https://standards.iteh.ai/catalog/standards/iec/7/7e6d88-d48a-4c99-8b82-748809d8d985/iec-61968-13-2008>

INTERNATIONAL ELECTROTECHNICAL COMMISSION

**APPLICATION INTEGRATION AT ELECTRIC UTILITIES –
SYSTEM INTERFACES FOR DISTRIBUTION MANAGEMENT –**

Part 13: CIM RDF Model exchange format for distribution

FOREWORD

- 1) The International Electrotechnical Commission (IEC) is a worldwide organization for standardization comprising all national electrotechnical committees (IEC National Committees). The object of IEC is to promote international co-operation on all questions concerning standardization in the electrical and electronic fields. To this end and in addition to other activities, IEC publishes International Standards, Technical Specifications, Technical Reports, Publicly Available Specifications (PAS) and Guides (hereafter referred to as "IEC Publication(s)"). Their preparation is entrusted to technical committees; any IEC National Committee interested in the subject dealt with may participate in this preparatory work. International, governmental and non-governmental organizations liaising with the IEC also participate in this preparation. IEC collaborates closely with the International Organization for Standardization (ISO) in accordance with conditions determined by agreement between the two organizations.
- 2) The formal decisions or agreements of IEC on technical matters express, as nearly as possible, an international consensus of opinion on the relevant subjects since each technical committee has representation from all interested IEC National Committees.
- 3) IEC Publications have the form of recommendations for international use and are accepted by IEC National Committees in that sense. While all reasonable efforts are made to ensure that the technical content of IEC Publications is accurate, IEC cannot be held responsible for the way in which they are used or for any misinterpretation by any end user.
- 4) In order to promote international uniformity, IEC National Committees undertake to apply IEC Publications transparently to the maximum extent possible in their national and regional publications. Any divergence between any IEC Publication and the corresponding national or regional publication shall be clearly indicated in the latter.
- 5) IEC provides no marking procedure to indicate its approval and cannot be rendered responsible for any equipment declared to be in conformity with an IEC Publication.
- 6) All users should ensure that they have the latest edition of this publication.
- 7) No liability shall attach to IEC or its directors, employees, servants or agents including individual experts and members of its technical committees and IEC National Committees for any personal injury, property damage or other damage of any nature whatsoever, whether direct or indirect, or for costs (including legal fees) and expenses arising out of the publication, use of, or reliance upon, this IEC Publication or any other IEC Publications.
- 8) Attention is drawn to the Normative references cited in this publication. Use of the referenced publications is indispensable for the correct application of this publication.
- 9) Attention is drawn to the possibility that some of the elements of this IEC Publication may be the subject of patent rights. IEC shall not be held responsible for identifying any or all such patent rights.

International Standard IEC 61968-13 has been prepared by IEC technical committee 57: Power systems management and associated information exchange.

The text of this standard is based on the following documents:

FDIS	Report on Voting
57/930/FDIS	57/955/RVD

Full information on the voting for the approval of this standard can be found in the report on voting indicated in the above table.

A list of all parts of the IEC 61968 series, under the general title *Application integration at electric utilities – System interfaces for distribution management*, can be found on the IEC website.

The committee has decided that the contents of this publication will remain unchanged until the maintenance result date indicated on the IEC web site under "<http://webstore.iec.ch>" in the data related to the specific publication. At this date, the publication will be

- reconfirmed;
- withdrawn;
- replaced by a revised edition, or
- amended.

A bilingual version of this publication may be issued at a later date.

Withdrawn

iTech Standards
(<https://standards.itih.ai>)
Document Preview

IEC 61968-13:2008
<https://standards.itih.ai/standards/iec/7/7e6d88-d48a-4c99-8b82-748809d8d985/iec-61968-13-2008>

INTRODUCTION

The IEC 61968 series of standards is intended to facilitate inter-application integration as opposed to intra-application integration. Intra-application integration is aimed at programs in the same application system, usually communicating with each other using middleware that is embedded in their underlying runtime environment, and tends to be optimized for close, real-time, synchronous connections and interactive request/reply or conversation communication models. IEC 61968, by contrast, is intended to support the inter-application integration of a utility enterprise that needs to connect disparate applications that are already built or new (legacy or purchased applications), each supported by dissimilar runtime environments. Therefore, these interface standards are relevant to loosely coupled applications with more heterogeneity in languages, operating systems, protocols and management tools. This series of standards is intended to support applications that need to exchange data every few seconds, minutes, or hours rather than waiting for a nightly batch run. This series of standards, which are intended to be implemented with middleware services that exchange messages among applications, will complement, not replace utility data warehouses, database gateways, and operational stores.

As used in IEC 61968, a DMS consists of various distributed application components for the utility to manage electrical distribution networks. These capabilities include monitoring and control of equipment for power delivery, management processes to ensure system reliability, voltage management, demand-side management, outage management, work management, automated mapping and facilities management. Standards interfaces are defined for each class of applications identified in the Interface Reference Model (IRM), which is described in IEC 61968-1.

iTech Standards

(<https://standards.iteh.ai>)

Document Preview

<https://standards.iteh.ai/standards/iec/719e6d88-d48a-4c99-8b82-748809d8d985/iec-61968-13-2008>

<https://standards.iteh.ai/standards/iec/719e6d88-d48a-4c99-8b82-748809d8d985/iec-61968-13-2008>

WITHDRAWN

APPLICATION INTEGRATION AT ELECTRIC UTILITIES – SYSTEM INTERFACES FOR DISTRIBUTION MANAGEMENT –

Part 13: CIM RDF Model exchange format for distribution

1 Scope

This part of IEC 61968 specifies the format and rules for exchanging modeling information based upon the CIM (Common Information Model) and related to distribution network data.

The intention of this part of IEC 61968 is to allow the exchange of instance data in bulk. Thus, the imported network model data should be sufficient to allow performing network connectivity analysis, including network tracing, outage analysis, load flow calculations, etc. This part could be used for synchronizing geographical information system databases with remote control system databases.

This part is closely linked to IEC 61970-452 Energy Management System Application Program Interface (EMS-API) CIM Network applications model exchange specification. Thus, this document has been written in order to reduce its maintenance. It describes only differences with IEC 61970-452. Nevertheless, as IEC 61970-452 is a future international standard, this part still has duplicate information with IEC 61970-452, in order to be more understandable.

It uses the CIM RDF¹⁾ Schema presented in IEC 61970-501 as the meta-model framework for constructing XML²⁾ documents containing power system modeling information. The syntax of these documents is called CIM XML format. Model exchange by file transfer serves many useful purposes, specially when some applications need to have the complete network model defined. Though the format can be used for general CIM-based information exchange, in this part of IEC 61968, specific profiles (or subsets) of the CIM are identified in order to address particular exchange requirements.

Given the CIM RDF Schema described in IEC 61970-501, a DMS power system model can be converted for export as an XML document, see Figure 1. This document is referred to as a CIM XML document. All of the tags (resource descriptions) used in the CIM XML document are supplied by the CIM RDF schema. The resulting CIM XML model exchange document can be parsed and the information imported into a foreign system. This part of IEC 61968 is aligned to CIM Model version 11, CPSM 3.0 profile.

1) RDF: Resource Description Framework.

2) XML: eXtensible Markup Language.

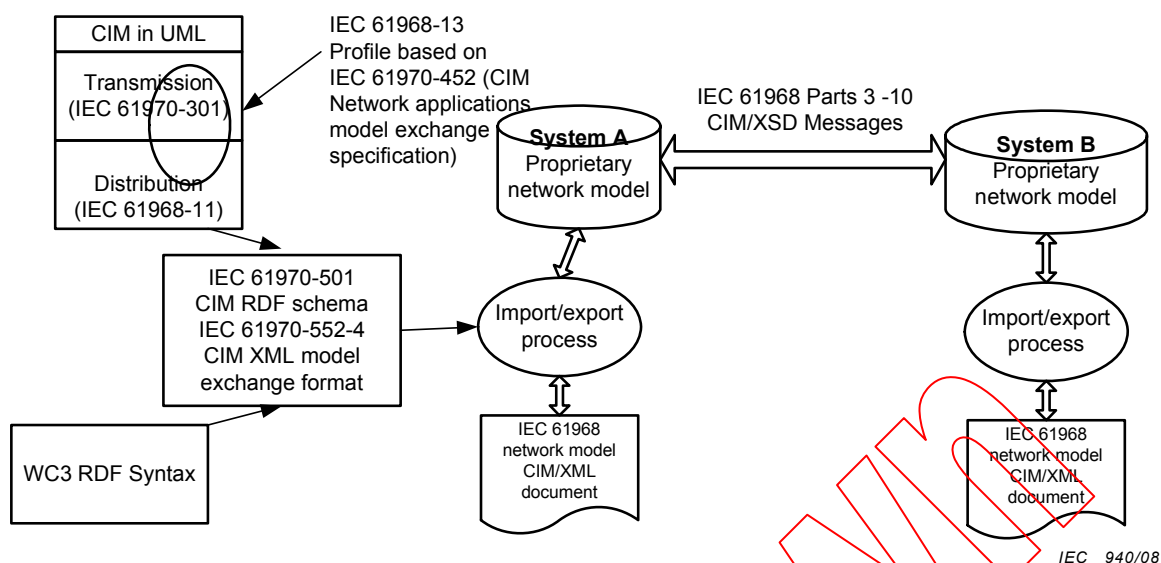

Figure 1 – XML-based DMS network data configuration

Similar to using any programming language, implementers have many choices when creating a CIM XML document. The RDF syntax itself can be used in several ways to achieve the same basic result. The way one approaches the CIM RDF Schema can yield various forms when producing a CIM XML document. The following clauses discuss the style guidelines for producing a CIM XML document. Such guideline rules are important to communicate and follow when producing these documents because they simplify and facilitate the software written to unambiguously interpret the model information.

Some comparisons have been made between CIM RDF and CIM XSD. Annexes A, B, C and D are extracted from articles and documents discussing CIM RDF and CIM XSD. A distribution management system can use only a CIM XSD message types architecture, but CIM RDF has three advantages:

- A UML model is a graph model and RDF helps to describe the graph model. XSD describes a hierarchical model which suits the message type approach.
- RDF is more readable and understandable by people working in the electrotechnical field.
- It is a basic requirement to build ontologies.

If required, tools would ensure the compatibility between CIM-RDF and, for instance, IEC 61968-4 and IEC 61968-3 message types concerning distribution network model representation.

2 Normative references

The following referenced documents are indispensable for the application of this document. For dated references, only the edition cited applies. For undated references, the latest edition of the referenced document (including any amendments) applies.

IEC 61968-1, *Application integration at electric utilities – System interfaces for distribution management – Part 1: Interface architecture and general requirements*

IEC 61968-3, *Application integration at electric utilities – System interfaces for distribution management – Part 3: Interface for network operations*

IEC 61968-4, *Application integration at electric utilities – System interfaces for distribution management – Part 4: Interfaces for records and asset management*

IEC 61970-301, *Energy management system application program interface (EMS-API) – Part 301: Common Information Model (CIM) base*

IEC 61970-501, *Energy management system application program interface (EMS-API) – Part 501: Common Information Model Resource Description Framework (CIM RDF) schema*

3 Future standards documents related to this part

The following documents are taken into account even if they have not been published as FDIS yet.

Extensions to CIM for Distribution: IEC 61968-11.

This document is used during interoperability tests: IEC 61970-452.

IEC 61970-552-4, *EMS-API – Part 552-4: CIM XML Model Exchange Format*.

4 CIM RDF describing distribution networks

In this part of the IEC 61968 standard, the object is to describe a CIM RDF model for the Distribution networks. It has the same objective as the NERC Common Power System Model (CPSM) Profile that has been agreed to at the Transmission level (reference: <http://www.w3.org/TR/2004/REC-rdf-primer-20040210> subclause 6.5, and IEC 61970-452). At the distribution level, several kinds of application exist such as Network Operation, Asset Management, Customer Information, Network Planning, Work Management, etc. Efforts on standardization of these applications are conducted at the IEC through the Technical Committee 57. For more information, refer to <http://www.cimuser.org> web site.

Electric utilities use power system models for a number of different purposes. For example, power system simulations are developed for planning and security analysis. An operational power system model may consist of thousands of classes of information. In addition to using these models in-house, applications inside an individual utility need to exchange system modelling information, both for planning and operational purposes (e.g. coordinating transmission and distribution networks and ensuring reliable operations). However, individual utilities use different software packages for these purposes. As a result, the system models are stored in different formats, making exchange among these models difficult. The exchange of model data is difficult and requires specific interface development for data exchange between each pair of applications. Consequently, the individual utilities recognize the need to agree on common definitions of the power system entities and relationships to facilitate the future data exchange requirements.

The CIM defines most of objects inside an electric utility as classes and attributes, as well as the relationships among them. The CIM uses these object classes, their attributes and relationships to support the integration of independently developed applications among vendor specific DMS applications. CIM represents a canonical data model to support data exchange between each part of a DMS system such as asset management, distribution planning, etc.

Based on the NERC CPSM Profile for the transmission network, this part of IEC 61968 proposes a CIM-RDF profile for modelling Distribution networks. This part of IEC 61968 defines a CDPSM profile (Common Distribution Power System Model). IEC 61968-13 will mention the differences between this part of IEC 61968 and CPSM profile when they occur.

The data intended for initial configuration of distribution network applications includes the applications such as distribution load flow calculation, dynamic network coloring, stability studies due to the impact of Distributed Energy Resources on Distribution Networks,

Distribution remote control system data management, exchange of data between TSO (Transmission System Operator) and DSO (Distribution System Operator), etc.

Consequently, the proposal is mainly based on IEC 61970-301, without, at the present time, the Asset classes found in IEC 61968-11. In the future, assetType attribute of Asset class will be used instead of PsrType if CIM IEC 61968-11 is normalized and incorporated officially in the CIM. In this part of IEC 61968, class Location is defined in the IEC 61968-11 packages.

This part of IEC 61968 is valid for three-phase balanced and unbalanced distribution networks. It is described as a single phase network and may have single- or two-phase components such as single-phase laterals and transformers³⁾. However, some users may find it convenient to restrict the proposed profile to include only the subset of three-phase balanced networks and exclude support for single phase components. In the Clauses which follow, the term “partial-phase devices” is used to describe components having less than three phases.

5 Issues related to partial-phase devices modeling

5.1 General

The IEC 61970-301 standard already has support for partial phase conducting devices through the phase-code attribute which may be a combination of any or all of the letters A, B, C, and N. In general, one can think of a partial phase conducting device as being the same as a full 3-phase device with some of the phases missing.

5.2 Impedances of unbalanced and partial phase devices

IEC 61970-301 specifies impedance of conducting devices in terms of the real and reactive positive and zero sequence impedance. Unfortunately, this is only valid for perfectly symmetric three-phase networks where all 3 phases have the same value of self-impedance and the same mutual impedance value.

The impedance of unbalanced 3-phase conducting devices such as AC line segments shall be specified as a three by three complex matrix where the diagonal terms specify the self impedance of each phase and the off-diagonal terms specify the mutual impedance between each phase pair. These values can be computed using Carson's equations based on the geometric mean radius, the linear resistance and the geometric arrangement of the three phases on the pole. IEC 61970-301 provides all the parameters necessary in the Conductor and WireArrangement classes. For 2-phase devices, the impedance matrix is two by two and for single-phase devices, it is a complex scalar specifying the self impedance of the single phase conductor.

5.3 Switches

IEC 61970-301 allows only two states for a switch device, i.e. open and closed. Thus for a 3-phase switch, it suggests that all three phases of the switch always operate together and it does not support the situation where, for example, phase A of the switch is open while phases B and C are closed. Of course, a single-phase switch may be open or closed.

5.4 Partial phase continuity in radial networks

Many distribution networks are operated radially, meaning that there is only one path for power to be supplied to any conducting device. For all phases of a device in a radial network to be properly energized, all devices upstream shall have the same phases present. (For

3) The USA radial electric distribution system is typically unbalanced. The main distribution feeder is three-phased with single-phased tapped load. The model exchange format should support a three-phased, unbalanced model to support, as an example, unbalanced load flow calculations.

example, it is not possible to energize all the phases of a three phase device via a partial phase upstream device.)

However, this requirement is not enforced in this part of IEC 61968. Rather, it is up to the importing DMS to check if this requirement is satisfied throughout the network.

6 CIM classes used and corresponding RDF

6.1 General

There is a large variety of voltage combinations in a substation. In addition, substations may generally contain one, two or more voltage levels. The applications needing such “substation type” information will deduce the substation type from the voltage levels it contains.

In general, substations may contain one, two or more voltage levels, the substation type will be deduced by analyzing the voltage levels a substation contains. The class PSRType can be used to distinguish these different substations. Class Location can be used to define the absolute position of a Substation.

Annex E gives a complete example of a Distribution Network Data represented through CIM-RDF. It should be pointed out that this complete example has been successfully tested during CIM interoperability tests conducted by EPRI in 2004, 2005, and 2006.

From the standpoint of a data producer (exporter), the document describes a minimum subset of CIM classes and class data which must be present in an XML formatted data file to comply with CDPSM Minimum Data Requirements. From the standpoint of a data recipient (importer), the document describes a subset of the CIM that an importer could reasonably expect to receive in an XML data file designed to be compliant with the CDPSM Minimum Data Requirements (see IEC 61970-501).

6.2 BaseVoltage and VoltageLevel

For every operating voltage found in the network, a BaseVoltage is created. An ACLineSegment is associated to a BaseVoltage. A TransformerWinding is associated to a BaseVoltage. PowerTransformer should be contained in a Substation.

Every Substation is associated with one or more VoltageLevel-s, each of which is in turn associated with the corresponding BaseVoltage.

All the objects of the network, except ACLineSegment, PowerTransformer and Transformer Winding should be contained within a VoltageLevel.

```

<cim:BaseVoltage rdf:ID="BaseVoltage_1">
  <cim:BaseVoltage.nominalVoltage>63</cim:BaseVoltage.nominalVoltage>
</cim:BaseVoltage>

<cim:BaseVoltage rdf:ID="BaseVoltage_2">
  <cim:BaseVoltage.nominalVoltage>42</cim:BaseVoltage.nominalVoltage>
</cim:BaseVoltage>

<cim:VoltageLevel rdf:ID="VL_1">
  <cim:Naming.name>NOD10S61</cim:Naming.name>
  <cim:VoltageLevel.MemberOf_Substation rdf:resource="#Substation_1"/>
  <cim:VoltageLevel.BaseVoltage rdf:resource="#BaseVoltage_1"/>
</cim:VoltageLevel>

<cim:VoltageLevel rdf:ID="VL_2">
  <cim:Naming.name>NOD10S62</cim:Naming.name>
  <cim:VoltageLevel.MemberOf_Substation rdf:resource="#Substation_1"/>
  <cim:VoltageLevel.BaseVoltage rdf:resource="#BaseVoltage_2"/>
</cim:VoltageLevel>

```

6.3 Containment hierarchy roots

The CPSM 2.0 profile of base CIM defines HostControlArea to be at the root of containment hierarchy. In contrast, this specification defines HV/MV Substation as the root of the containment hierarchy.

6.4 HV/MV substation

The containment hierarchy begins by HV/MV Substation.

```

<cim:Substation rdf:ID="Substation_1">
  <cim:Naming.name>AIGUE_HVMV</cim:Naming.name>
  <cim:Substation.PSRType rdf:resource="#PSRType_1">
</cim:Substation>

<cim:PSRType rdf:ID="PSRType_1">
  <cim:Naming.name>HV/MV Substation</cim:Naming.name>
</cim:PSRType>

<cim:Location rdf:ID="Location_1">
  <cim:Location.PowerSystemResource rdf:resource="#Substation_1">
</cim:Location>

<cim:GmlPosition rdf:ID="CP_1">
  <cim:GmlPosition.xPosition>910700</cim:GmlPosition.xPosition>
  <cim:GmlPosition.yPosition>66270</cim:GmlPosition.yPosition>
  <cim:Location rdf:resource="#Location_1">
</cim:GmlPosition>

```

6.5 MV/MV substation

```

<cim:Substation rdf:ID="Substation_2">
  <cim:Naming.name>AIGUE_MVMV</cim:Naming.name>
  <cim:Substation.PSRType rdf:resource="#PSRType_2">
</cim:Substation>

<cim:PSRType rdf:ID="PSRType_2">
  <cim:Naming.name>MV/MV Substation</cim:Naming.name>
</cim:PSRType>

<cim:Location rdf:ID="Location_2">
  <cim:Location.PowerSystemResource rdf:resource="#Substation_2">
</cim:Location>

<cim:GmlPosition rdf:ID="CP_1">
  <cim:GmlPosition.xPosition>910700</cim:GmlPosition.xPosition>
  <cim:GmlPosition.yPosition>66270</cim:GmlPosition.yPosition>
  <cim:Location rdf:resource="#Location_2">
</cim:GmlPosition>

```