

---

# International Standard



# 7844

---

INTERNATIONAL ORGANIZATION FOR STANDARDIZATION • МЕЖДУНАРОДНАЯ ОРГАНИЗАЦИЯ ПО СТАНДАРТИЗАЦИИ • ORGANISATION INTERNATIONALE DE NORMALISATION

---

## Grooved vertical joints with connecting bars and concrete infill between large reinforced concrete panels — Laboratory mechanical tests — Effect of tangential loading

**iTeh STANDARD PREVIEW**

*Assemblages verticaux crantés à armatures de liaison et béton coulé en place entre grands panneaux en béton armé — Méthode d'essai mécanique en laboratoire — Sollicitations résultant de l'application d'efforts tangentiels*

First edition — 1985-11-15

[ISO 7844:1985](#)

<https://standards.itih.ai/catalog/standards/sist/1aef3238-6189-4225-8efe-e1b2b338041e/iso-7844-1985>

---

UDC 624.078.3 : 620.17

Ref. No. ISO 7844-1985 (E)

Descriptors : buildings, joints, tests, specimen preparation, test specimens, test equipment, deformation, mechanical properties.

## Foreword

ISO (the International Organization for Standardization) is a worldwide federation of national standards bodies (ISO member bodies). The work of preparing International Standards is normally carried out through ISO technical committees. Each member body interested in a subject for which a technical committee has been established has the right to be represented on that committee. International organizations, governmental and non-governmental, in liaison with ISO, also take part in the work.

Draft International Standards adopted by the technical committees are circulated to the member bodies for approval before their acceptance as International Standards by the ISO Council. They are approved in accordance with ISO procedures requiring at least 75 % approval by the member bodies voting.

International Standard ISO 7844 was prepared by Technical Committee ISO/TC 59, *Building construction*.

Users should note that all International Standards undergo revision from time to time and that any reference made herein to any other International Standard implies its latest edition, unless otherwise stated.

iTeh STANDARD PREVIEW  
(standards.iteh.ai)

# Grooved vertical joints with connecting bars and concrete infill between large reinforced concrete panels — Laboratory mechanical tests — Effect of tangential loading

## iTeh STANDARD PREVIEW (standards.iteh.ai)

### 0 Introduction

The analysis of structures comprising large panels has shown the importance of the role that can be played by vertical joints between wall elements.

Modern methods of calculation allow the influence of these joints to be taken into account when sufficient knowledge of their behaviour is available, and the purpose of this International Standard is, therefore, to provide a method for the experimental determination of the principal elements of the behaviour of some of these joints.

This International Standard does not deal with the interpretation or use of the test results. In particular, as these are tests which are often difficult to perform in large numbers, this International Standard does not specify a minimum repetition factor. Attention is drawn, however, to the dispersion which often affects the results of such tests and to the desirability of repeating several times those tests which are most representative of the real conditions.

The mechanical characteristics of vertical joints between reinforced concrete panels which are taken into account in design calculations for bracing walls formed of large panels can be expressed by means of the relationship between tangential loading and the relative displacement of the panels linked by the joint concerned.

### 1 Scope

This International Standard specifies a laboratory mechanical method of test for the determination of the relationship between tangential loading and relative displacement for certain types of vertical joints between large reinforced concrete panels subjected to tangential loading.

### 2 Field of application

This International Standard is applicable to vertical joints between large wall-panels satisfying the following conditions :

- a) the edges of the panels shall have a geometric form which allows the infill concrete of the joint to play a role as a distributing mechanical wedge;
- b) the reinforcement connecting the two wall-panels shall be distributed uniformly over the total height of the storey and the vertical distance between reinforcing bars shall be small;
- c) the strength of the concrete constituting the panels shall be at least equal to the strength of the infill concrete of the joint.

This International Standard is applicable in the case of effects produced by tangential loading (shearing along the joint).

### 3 Principle

Submission of test pieces, comprising two side pieces of panels jointed together, to tangential loading. Noting the deformation of the test pieces and deterioration (cracking and failure) for different values of tangential loading.

### 4 Test apparatus

The test apparatus shall be able

- to ensure rigid fixing of the side pieces;
- to allow slippage in the axis of the joint;

- to avoid deformation of the installation up to failure of the test piece;
- to ensure application of the load in the direction of the axis of the joint.

- in direction :  $\pm 5 \times 10^{-3}$  rad relative to the longitudinal axis of the joint;
- in geometric deviation in the middle of the joint : 2 mm.

The accuracy required for the test apparatus (in the case of joints of strictly perfect dimensions) is as follows :

The test apparatus may be designed to allow joints to be tested in the horizontal (see figure 1) or vertical (see figure 2) position.

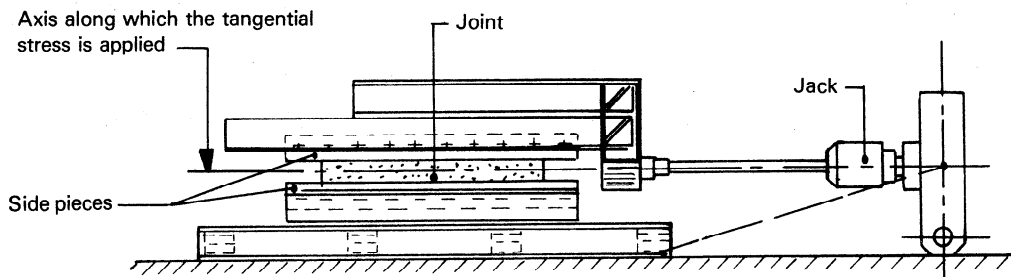

Figure 1 — Example of test apparatus for testing in one direction in horizontal position

(standards.iteh.ai)

ISO 7844:1985

<https://standards.iteh.ai/catalog/standards/sist/1aef3238-6189-4225-8efe-e1b2b338041e/iso-7844-1985>

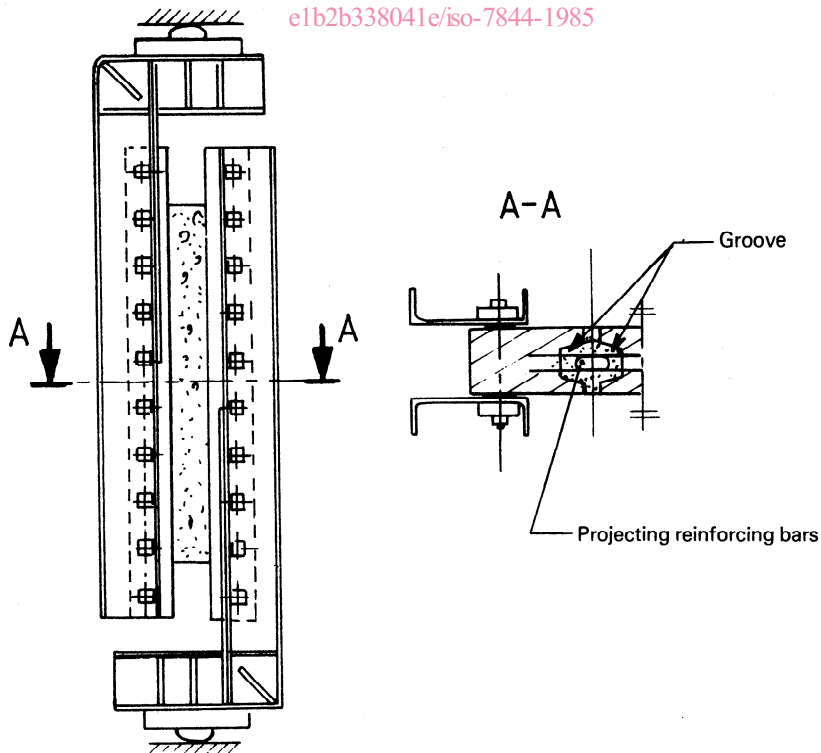

Figure 2 — Example of device for testing in one direction in vertical position

## 5 Test pieces

### 5.1 Composition and dimensions

A test piece consists of two side pieces representing the sides of panels and the joint itself situated between these side pieces (see figure 3).

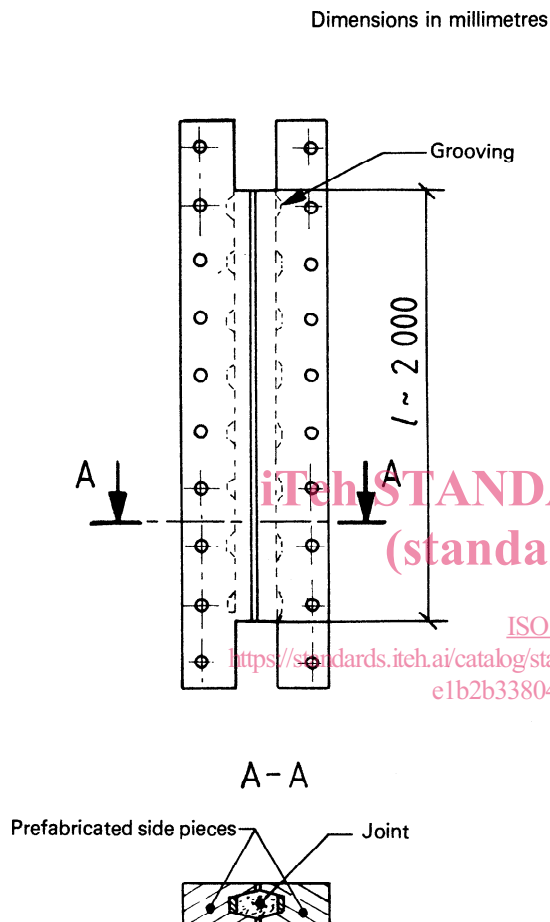

Figure 3 — Shape and dimensions of test pieces

The edge of each side piece, adjacent to the joint, reproduces the shape of the vertical edge of a panel with grooves, with optional flanges designed to close the joint and projecting reinforcing bars. On the opposite side to the joint, the edge is designed to be fastened in the test apparatus. The reinforcement is thus quite dense in this area and traversing gaps provide holes for the fixing devices of the test apparatus. The concrete on the side adjacent to the joints shall have the same strength and composition as that of the panels.

NOTE — On the side to be fixed in the test apparatus, the cement content of the concrete on the edges may be increased if necessary, so as to improve the strength and to avoid premature cracking near the fixing points.

The thickness through the joint shall be identical to that of the actual joint in service; it can be adapted to the characteristics of the test apparatus at the fixing points.

The length of joint to be tested shall be approximately 2 000 mm.

### 5.2 Preparation

The preparation of the test pieces shall reproduce site practice as closely as possible. The concrete used in the joint shall thus have a composition and workability as close as possible to those for use on site. For a research test, however, the possibility of concreting with the joint in a horizontal position, and not systematically in the vertical position as on the site, can be allowed. For qualification tests, the preparation, including concreting, shall be identical to practice.

## 6 Procedure

### 6.1 Preliminary loosening

Before testing, the joint shall be loosened from one side piece. This can be done with small jacks acting perpendicularly to the side pieces and can be facilitated by using a demoulding agent<sup>1)</sup> on the surfaces of the side pieces. This operation should be stopped when a crack is visible along the total contact surface between the joint and one of the side pieces and the opening has a width of approximately 0,2 mm all along its length and on the two faces of the test pieces.

### 6.2 Determination

#### 6.2.1 Static test in one direction

The test shall be carried out by increasing the relative tangential displacement of the two side pieces by applying a tangential load to the joint.

Increase the load either step by step with chosen increments so that, taking into account the known or estimated limit state, this will be reached after about 10 increases, or, preferably, continuously (when the relative displacement is recorded continuously). Even when this last procedure is used, several returns to zero loading are admissible during the test. Stop the test either when the joint shows heavy deterioration (failure of several projecting reinforcing bars, crushing of the concrete) or when the relative displacement of the two edges reaches 20 mm.

1) The use of a demoulding agent is recommended in the case of self-forming joints in order to eliminate the risk of rupture of the infill joint concrete.

**6.2.2 Test with alternating tangent loads**

When it is necessary to know the behaviour of a joint on which alternating tangential loads are exerted, the test comprises successive stages during which the joint is submitted to alternating deformations, of contrary signs and the same absolute value, until a stable curve loop of load-deformation is obtained (see figure 4) or until 10 cycles have been carried out if a stable loop is not obtained.

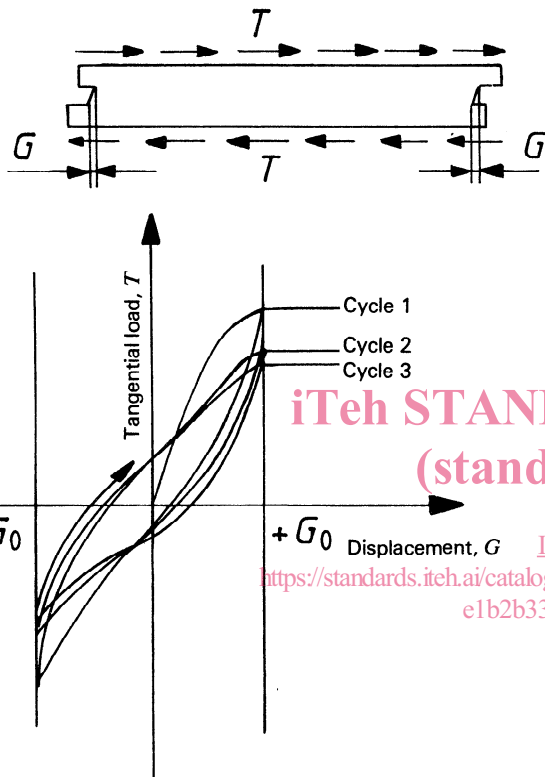

**Figure 4 — Example of tangential load-displacement diagram for an alternating shear test with imposed displacement**

The next phase is then carried out for a higher value of limit deformation and the test is terminated by a static test in one direction.

The level of deformation to set is to be defined according to the problem under investigation (for example relatively small deformations for wind in service or large deformations in the case of seismic loading).

**6.3 Test results**

**6.3.1 Maximum shear-resistance of the joint**

The maximum shear-resistance of the joint is the maximum force registered during the test. It is expressed in newtons.

**6.3.2 Deformation**

The deformation of the joint is the relative displacement of the side pieces parallel to the direction of the force. Such deformations shall be measured preferably by means of a continuous recording<sup>1)</sup>, mid-way along the test piece, on its two faces. The related displacements of the edges at the ends of the joint, and the increase in width of the joint at its two ends, shall also be measured. The deformation is expressed in millimetres.

**7 Test report**

For each test carried out, the test report shall include the following information :

- a) the dimensions and shapes of the test piece and of the joint, and the shapes, dimensions and positions of connecting reinforcing bars, and of the reinforcement of the joint;
- b) the method of preparing the joint (horizontally or vertically);
- c) a diagram of the test apparatus indicating, in the case of a horizontal test, the normal stress applied to the joint by the test apparatus;
- d) the programme for increasing the loading (rate of loading for a static test, imposed deformations for an alternating test);
- e) the deformations registered parallel and perpendicular to the direction of loading, expressed as a function of the load;
- f) the formation of cracks and their development characterized by the position of the ends of cracks for different values of the force applied;
- g) the maximum shear resistance of the joint per unit length of the junction.

1) The shape of the load-deformation curve gives important information on the behaviour of the joint.

**iTeh STANDARD PREVIEW**  
**(standards.iteh.ai)**

This page intentionally left blank

[ISO 7844:1985](#)

<https://standards.iteh.ai/catalog/standards/sist/1aef3238-6189-4225-8efe-e1b2b338041e/iso-7844-1985>

**iTeh STANDARD PREVIEW**  
**(standards.iteh.ai)**

This page intentionally left blank

[ISO 7844:1985](#)

<https://standards.iteh.ai/catalog/standards/sist/1aef3238-6189-4225-8efe-e1b2b338041e/iso-7844-1985>