



Designation: C 1499 – 01

Standard Test Method for Monotonic Equibiaxial Flexural Strength of Advanced Ceramics at Ambient Temperature¹

This standard is issued under the fixed designation C 1499; the number immediately following the designation indicates the year of original adoption or, in the case of revision, the year of last revision. A number in parentheses indicates the year of last reapproval. A superscript epsilon (ϵ) indicates an editorial change since the last revision or reapproval.

1. Scope

1.1 This standard test method covers the determination of the equibiaxial strength of advanced ceramics at ambient temperature via concentric ring configurations under monotonic uniaxial loading. In addition, test specimen fabrication methods, testing modes, testing rates, allowable deflection, and data collection and reporting procedures are addressed. Two types of test specimens are considered: machined specimens and as-fired specimens exhibiting a limited degree of warpage. Strength as used in this test method refers to the maximum strength obtained under monotonic application of load. Monotonic loading refers to a test conducted at a constant rate in a continuous fashion, with no reversals from test initiation to final fracture.

1.2 This test method is intended primarily for use with advanced ceramics that macroscopically exhibit isotropic, homogeneous, continuous behavior. While this test method is intended for use on monolithic advanced ceramics, certain whisker- or particle-reinforced composite ceramics as well as certain discontinuous fiber-reinforced composite ceramics may also meet these macroscopic behavior assumptions. Generally, continuous fiber ceramic composites do not macroscopically exhibit isotropic, homogeneous, continuous behavior, and the application of this test method to these materials is not recommended.

1.3 Values expressed in this test method are in accordance with the International System of Units (SI) and Practice E 380.

1.4 *This standard does not purport to address all of the safety concerns, if any, associated with its use. It is the responsibility of the user of this standard to establish appropriate safety and health practices and determine the applicability of regulatory limitations prior to use.*

2. Referenced Documents

2.1 ASTM Standards:

C 1145 Terminology on Advanced Ceramics²

¹ This test method is under the jurisdiction of ASTM Committee C28 on Advanced Ceramics and is the direct responsibility of Subcommittee C28.01 on Properties and Performance.

Current edition approved June 10, 2001. Published August 2001.

² *Annual Book of ASTM Standards*, Vol 15.01.

- C 1239 Reporting Uniaxial Strength Data and Estimating Weibull Distribution Parameters for Advanced Ceramics²
- C 1259 Test Method for Dynamic Young's Modulus, Shear Modulus and Poisson's Ratio for Advanced Ceramics by Impulse Excitation of Vibration²
- C 1322 Practice for Fractography and Characterization of Fracture Origins in Advanced Ceramics²
- E 4 Practices for Load Verification of Testing Machines³
- E 6 Terminology Relating to Methods of Mechanical Testing³
- E 83 Practice for Verification and Classification of Extensometers³
- E 337 Test Method for Measured Humidity with Psychrometer (The Measurement of Wet-and Dry-Bulb Temperatures)⁴
- E 380 Practice for Use of International System of Units (SI) (the Modernized Metric System)⁵
- F 394 Test Method for Biaxial Flexure Strength of Ceramic Substrates⁶

3. Terminology

3.1 *Definitions*—The definitions of terms relating to biaxial testing appearing in Terminology E 6 and Terminology C 1145 may apply to the terms used in this test method. Pertinent definitions are listed below with the appropriate source given in parentheses. Additional terms used in conjunction with this test method are defined in the following section.

3.1.1 *advanced ceramic, n*—a highly engineered, high performance predominately non-metallic, inorganic, ceramic material having specific functional attributes. **C 1145**

3.1.2 *breaking load, [F], n*—the load at which fracture occurs. **E 6**

3.1.3 *equibiaxial flexural strength, [F/L₂], n*—the maximum value of stress that a material is capable of sustaining when subjected to flexure between two concentric rings. This mode of flexure is a cupping of the circular plate caused by loading at the inner load ring and outer support ring. The equibiaxial

³ *Annual Book of ASTM Standards*, Vol 03.01.

⁴ *Annual Book of ASTM Standards*, Vol 07.01, 11.03, 15.09.

⁵ *Annual Book of ASTM Standards*, Vol 14.02.

⁶ *Annual Book of ASTM Standards*, Vol 15.02.

flexural strength is calculated from the maximum-load of a biaxial test carried to rupture, the original dimensions of the specimen, and Poisson's ratio.

3.1.4 *homogeneous, n*—the condition of a material in which the relevant properties (composition, structure, density, etc.) are uniform, so that any smaller sample taken from an original body is representative of the whole. Practically, as long as the geometrical dimensions of a sample are large with respect to the size of the individual grains, crystals, components, pores, or microcracks, the sample can be considered homogeneous.

3.1.5 *modulus of elasticity, $[F/L_2]$, n*—the ratio of stress to corresponding strain below the proportional limit. **E 6**

3.1.6 *Poisson's ratio, n*—the negative value of the ratio of transverse strain to the corresponding axial strain resulting from uniformly distributed axial stress below the proportional limit of the material.

4. Significance and Use

4.1 This test method may be used for material development, material comparison, quality assurance, characterization and design code or model verification.

4.2 Engineering applications of ceramics frequently involve biaxial tensile stresses. Generally, the resistance to equibiaxial flexure is the measure of the least flexural strength of a monolithic advanced ceramic. The equibiaxial flexural strength distributions of ceramics are probabilistic and can be described by a weakest link failure theory, (1, 2). Therefore, a sufficient number of test specimens at each testing condition is required for statistical estimation of the equibiaxial strength.

4.3 Equibiaxial strength tests provide information on the strength and deformation of materials under multiple tensile stresses. Multiaxial stress states are required to effectively evaluate failure theories applicable to component design, and to efficiently sample surfaces that may exhibit anisotropic flaw distributions. Equibiaxial tests also minimize the effects of specimen edge preparation as compared to uniaxial tests because the generated stresses are lowest at the specimen edges.

4.4 The test results of equibiaxial test specimens fabricated to standardized dimensions from a particular material and/or selected portions of a component may not totally represent the strength properties in the entire, full-size component or its in-service behavior in different environments.

4.5 For quality control purposes, results derived from standardized equibiaxial test specimens may be considered indicative of the response of the bulk material from which they were taken for any given primary processing conditions and post-processing heat treatments or exposures.

5. Interferences

5.1 Test environment (vacuum, inert gas, ambient air, etc.) including moisture content (e.g. relative humidity) may have an influence on the measured equibiaxial strength. Testing to evaluate the maximum strength potential of a material can be conducted in inert environments and/or at sufficiently rapid testing rates so as to minimize any environmental effects. Conversely, testing can be conducted in environments, test modes and test rates representative of service conditions to evaluate material performance under use conditions.

5.2 Fabrication of test specimens can introduce dimensional variations that may have pronounced effects on the measured equibiaxial mechanical properties and behavior (e.g. shape and level of the resulting stress-strain curve, equibiaxial strength, failure location, etc.). Surface preparation can also lead to the introduction of residual stresses and final machining steps might or might not negate machining damage introduced during the initial machining. Therefore, as universal or standardized methods of surface preparation do not exist, the test specimen fabrication history should be reported. In addition, the nature of fabrication used for certain advanced ceramic components may require testing of specimens with surfaces in the as-fabricated condition (i.e., it may not be possible, desired or required to machine some of the test specimen surfaces directly in contact with the test fixture). For very rough or wavy as-fabricated surfaces, perturbations in the stress state due to non-symmetric cross-sections as well as variations in the cross-sectional dimensions may also interfere with the equibiaxial strength measurement. Finally, close geometric tolerances, particularly in regard to flatness of test specimen surfaces in contact with the test fixture components are critical requirements for successful equibiaxial tests. In some cases it may be appropriate to use other test methods (e.g. F 394).

5.3 Contact and frictional stresses in equibiaxial tests can introduce localized failure not representative of the equibiaxial strength under ideal loading conditions. These effects may result in either over or under estimates of the actual strength (1, 3).

5.4 Fractures that consistently initiate near or just outside the load-ring may be due to factors such as friction or contact stresses introduced by the load fixtures, or via misalignment of the test specimen rings. Such fractures will normally constitute invalid tests (see Note 14). Splitting of the test specimen along a diameter that expresses the characteristic size may result from poor specimen preparation (e.g. severe grinding or very poor edge preparation), excessive tangential stresses at the specimen edges, or a very weak material. Such fractures will constitute invalid tests if failure occurred from the edge.

5.5 Deflections greater than one-half of the test specimen thickness can result in nonlinear behavior and stresses not accounted for by simple plate theory.

5.6 Warpage of the test specimen can result in nonuniform loading and contact stresses that result in incorrect estimates of the specimen's actual equibiaxial strength. The test specimen shall meet the flatness requirements (see sections 8.2 and 8.3) or be specifically noted as warped and considered as a censored test.

6. Apparatus

6.1 *Testing Machines*—Machines used for equibiaxial testing shall conform to the requirements of Practice E 4. The load cells used in determining equibiaxial strength shall be accurate within $\pm 1\%$ at any load within the selected load range of the testing machine as defined in Practice E 4. Check that the expected breaking load for the desired test specimen geometry and test material is within the capacity of the test machine and load cell. Advanced ceramic equibiaxial test specimens require

greater loads to fracture than those usually encountered in uniaxial flexure of test specimens with similar cross sectional dimensions.

6.2 Loading Fixtures for Concentric Ring Testing—An assembly drawing of a fixture and a test specimen is shown in Fig. 1, and the geometries of the load and support rings are given in Fig. 2.

6.2.1 Loading Rods and Platens—Surfaces of the support platen shall be flat and parallel to 0.05 mm. The face of the load rod in contact with the support platen shall be flat to 0.025 mm. In addition, the two loading rods shall be parallel to 0.05 mm per 25 mm length and concentric to 0.25 mm when installed in the test machine.

6.2.2 Loading Fixture and Ring Geometry—Ideally, the bases of the load and support fixtures should have the same outer diameter as the test specimen for ease of alignment. Parallelism and flatness of faces as well as concentricity of the load and support rings shall be as given in Fig. 2. The ratio of the load ring diameter, D_L , to that of the support ring, D_S , shall be $0.2 \leq D_L/D_S \leq 0.5$. For test materials exhibiting low elastic modulus ($E < 100$ GPa) and high strength ($\sigma_f > 1$ GPa) it is recommended that the ratio of the load ring diameter to that of the support ring be $D_L/D_S = 0.2$. The sizes of the load and support rings depend on the dimensions and the properties of the ceramic material to be tested. The rings are sized to the thickness, diameter, strength, and elastic modulus of the ceramic specimens (see Section 8). For test specimens made from typical substrates ($h \approx 0.5$ mm), a support ring diameter as small as 12 mm may be required. For test specimens to be used for model verification, it is recommended that the test specimen support diameter be at least 35 mm. The tip radius, r , of the cross sections of the load and support rings should be $h/2 \leq r \leq 3h/2$.

6.2.3 Load and Support Ring Materials—For machined test specimens (see Section 8) the load and support fixtures shall be made of hardened steel of $HR_C > 40$. For as-fabricated test specimens, the load/support rings shall be made of steel or acetyl polymer.

6.2.4 Compliant Layer and Friction Elimination—The brittle nature of advanced ceramics and the sensitivity to misalignment, contact stresses and friction may require a compliant interface between the load/support rings and the test specimen, especially if the specimen is not flat. Line or point contact stresses and frictional stresses can lead to crack initiation and fracture of the test specimen at stresses other than the actual equibiaxial strength.

6.2.4.1 Machined Test Specimens—For test specimens machined according to the tolerance in Fig. 3, a compliant layer is not necessary. However, friction needs to be eliminated. Place a sheet of carbon foil (~0.13 mm thick) or Teflon tape (~0.7 mm thick) between the compressive and tensile surfaces of the test specimen and the load and support rings.

NOTE 1—Thicker layers of carbon foil or Teflon tape may be used, particularly for very strong plates. However, excessively thick layers will redistribute the contact region and may affect results. The thicknesses listed above have been used successfully. Guidance regarding the use of thick layers cannot be given currently; some judgement may be required.

Alternatively, an appropriate lubricant (anti-seizing compound or Teflon oil) may be used to minimize friction. The lubricant should be placed only on the load and support rings so that effects of the test environment are not significantly altered. To aid fractographic examination, place a single strip of adhesive tape with a width of D_L or greater on the compressive face of the test specimen. Do not use multiple strips of tape, or a strip of tape with width less than D_L , as this may result in nonuniform loading.

6.2.4.2 As-Fabricated Test Specimens—If steel load and support rings are used to test as-fabricated specimens (e.g. as-fired ceramics and glass specimens), minimize the effects of specimen-ring misalignment by placing a sheet of rubber or silicone (Shore hardness of 60 ± 5) of approximately one-half the specimen thickness between the test specimen and the support ring. To aid fractographic examination, place a single strip of adhesive tape with a width of D_L or greater on the compressive face of the test specimen. Do not use multiple strips of tape, or a strip of tape with width less than D_L , as this may result in nonuniform loading. To minimize the effects of friction at the load ring interface, place a sheet of carbon foil or Teflon tape between the compressive surface of the test specimen and the load-ring. Alternatively, an appropriate lubricant (anti-seizing compound or Teflon oil) may be used to minimize friction at the load ring. If acetyl polymer load rings are used, a compliant layer is not required. Minimize the effects of friction at the load ring interface, by placing a sheet of carbon foil or Teflon tape between the compressive and tensile surfaces of the test specimen and the load and support rings. Alternatively, an appropriate lubricant (anti-seizing compound or Teflon oil) may be used to minimize friction at the load ring.

NOTE 2—As-fabricated test specimens that meet the flatness requirements in Fig. 3 may be tested as described in 6.2.4.1. A compliant layer is not necessary.

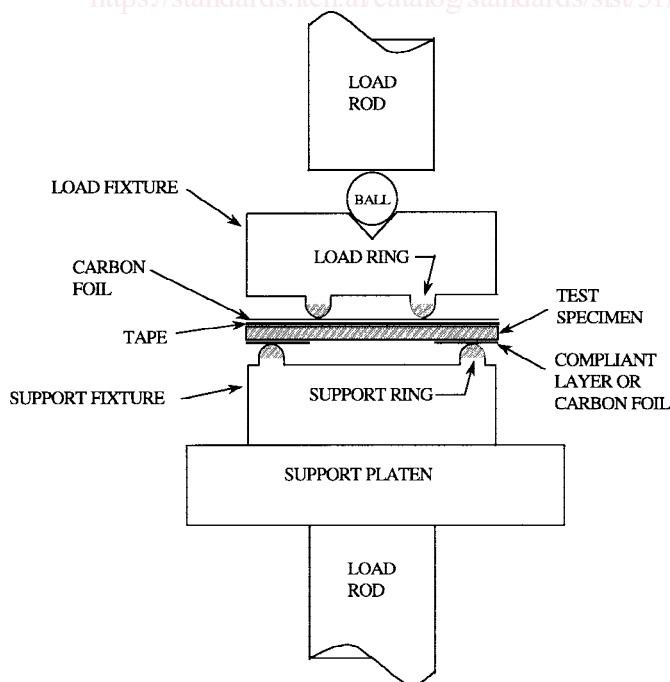

FIG. 1 Section View of Basic Fixturing and Test Specimen for Equibiaxial Testing

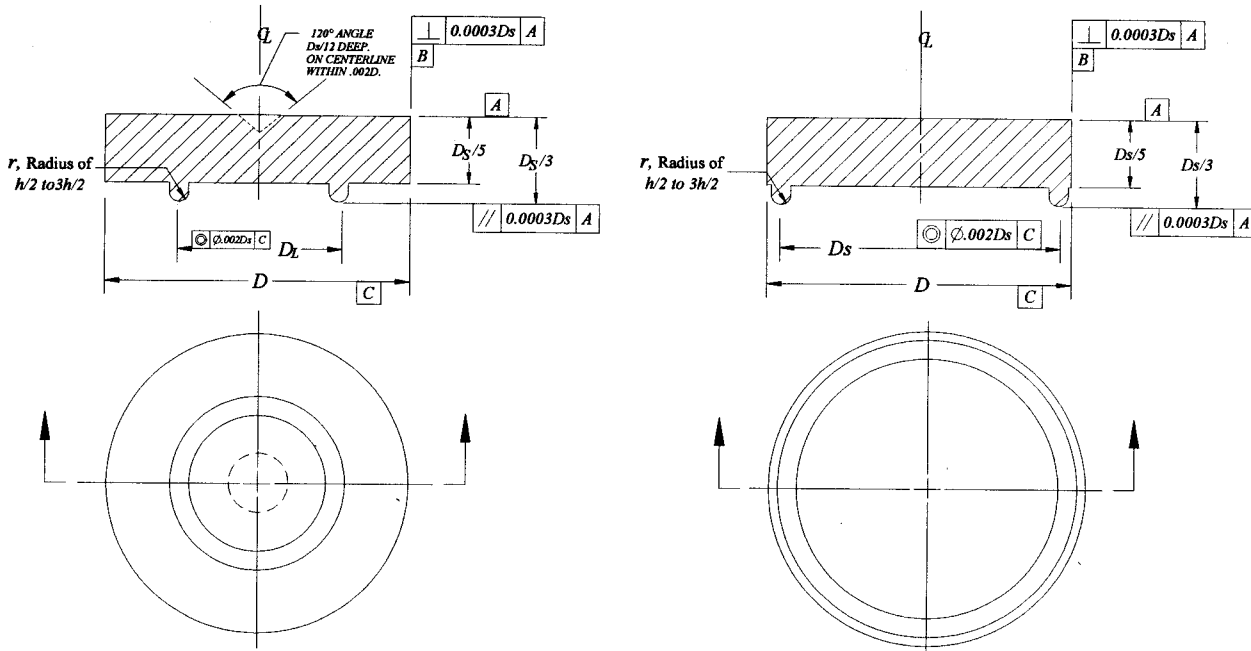
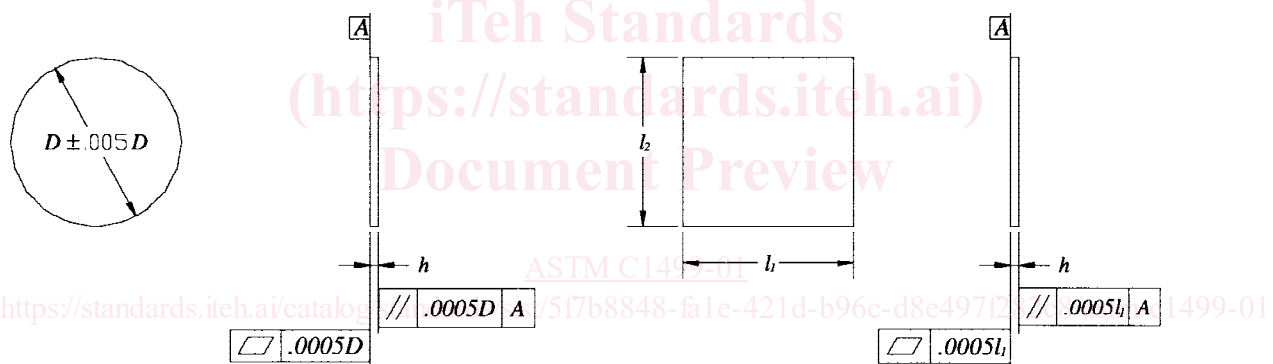

FIG. 2 Load and Support Fixture Designs for Equibiaxial Testing



Round Test Specimen

Rectangular Test Specimen

FIG. 3 Recommended Equibiaxial Test Specimen Geometry (h and D or l_1 and l_2 are Determined from Eq 1-3).

NOTE 3—The use of acetyl polymer load rings can result in sufficiently low friction (4) so that no layer is required. If the friction coefficient is less than 0.05, then the friction reduction layer may be eliminated.

6.3 *Alignment*—The load ring, support ring and test specimen shall be aligned concentrically to 0.5 % of the support ring diameter. For circular test specimens, the load and support rings and the test specimen can be aligned via a V-block placed on the support platen and held in place via adhesive or mechanical stops. Alternatively, a depth gage can be used to center the load and support rings and the test specimen. For rectangular specimens, a V-block with a 90° angle can be used.

6.4 *Allowable Deflection*—Excessive deflections can result in a calculated equibiaxial strength different than the actual equibiaxial strength. The test specimens allowed in this standard are designed to avoid excessive deflection (3, 5-7).

Measurement of deflection is not required, however, center-point deflection can be measured using a deflectometer mounted in the test fixturing (E 83). Load-point deflection also may be measured via the test machine actuator, however, appropriate corrections for the test system compliance may need to be applied to the deflection data. Alternatively, deflection can be estimated via the elastic solutions given in section 10.1.

6.5 *Data Acquisition*—At the minimum, obtain an autographic record of applied load versus time. Either analog chart recorders or digital data acquisition systems can be used for this purpose although a digital record is recommended for ease of later data analysis. Ideally, an analog chart recorder or plotter should be used in conjunction with the digital data

acquisition system to provide an immediate record of the test as a supplement to the digital record. Recording devices shall be accurate to within $\pm 1\%$ of the selected range for the testing system including readout unit, as specified in Practice E 4, and shall have a minimum data acquisition rate of 10 Hz with a rate of 50 Hz preferred for the rates recommended in section 9.2.2. If faster loading rates are used, then use an acquisition rate adequate to provide an error less than $\pm 1\%$ in the load reading.

6.5.1 Record crosshead displacement of the test machine or time similarly to the load or as independent variables of load.

6.6 *Dimension-Measuring Devices*—Micrometers and other devices used for measuring linear dimensions shall be accurate and precise to at least one half the smallest unit to which the individual dimension is required to be measured. For measuring the thickness, a micrometer with flat anvil faces a resolution better than or equal 0.002 mm is required. Ball-tipped or sharp anvil micrometers are not allowed because localized damage (e.g., cracking) can be induced.

NOTE 4—Thickness measurement is especially critical to the calculation of the strength when the test specimens are less than 1 mm thick.

7. Precautionary Statement

7.1 Fractures of loaded advanced ceramics can occur at large loads and high strain energies. To prevent the release of uncontrolled fragments, polycarbonate shielding or equivalent is recommended for operator safety and to capture specimen fragments to aid fractography.

7.2 Fractures can create fine particles that may be a health hazard. Materials containing whiskers, small fibers or silica particles may also cause health hazards. For such materials, the operator is advised to consult the material safety data sheet for guidance prior to testing. Suitable ventilation or masks may be warranted.

8. Test Specimens

8.1 *Test Specimen Dimensions*—Fig. 3 illustrates test specimen geometry. The relative dimensions are chosen to ensure behavior reasonably described by simple plate theory. Choose the dimension such that the test specimen thickness, h , in units of mm, is

$$\frac{D_s}{10} \leq h \leq \sqrt{\sigma_f D_s^2 / E} \quad (1)$$

where:

- D_s = the support ring diameter in units mm,
- σ_f = the expected equibiaxial fracture strength in units MPa, and
- E = the modulus of elasticity in units MPa (C 1259).

Choose the test specimen and support ring diameters such that the difference in diameters ($D - D_s$) is

$$2 \leq \frac{D - D_s}{h} \leq 12 \quad (2)$$

where:

- D = the test specimen diameter in units of mm for circular test specimens.

It is recommended that the test specimens be circular, however, in some cases it is advantageous to fabricate rectangular test specimens.

NOTE 5—For test specimens machined according to 8.2.3, a nondimensionalized overhang of $(D - D_s)/h = 2$ is generally sufficient. However, for test specimens that are scored from larger plates or for test specimens with poor edge finish, a nondimensionalized overhang of $(D - D_s)/h = 12$ may be required.

For a rectangular test specimen, D is the diameter of a circle that expresses the characteristic size of the plate as follows:

$$D = 0.6(l_1 + l_2) \quad (3)$$

where:

l_1 and l_2 = the lengths of the edges. The edge lengths should be within $0.98 \leq l_1/l_2 \leq 1.02$.

8.2 *Test Specimen Preparation: Machined Specimens*—A variety of surface preparations are acceptable. Unless the process used is proprietary, report specifics about the stages of material removal, wheel grits, wheel bonding, amount of material removed per pass, and type of coolant used. Regardless of the procedure used to machine the tensile surface of the specimen, the flatness of the faces as well as the flatness of the edges shall be as specified in Fig. 3.

8.2.1 *Application-Matched Machining*—The tensile face of the equibiaxial test specimen will have the same surface/edge preparation as that given to a service component.

NOTE 6—An example of application matched machining is blanchard grinding of electronic substrates. Although damage may exist, it is acceptable as the component has such damage in its application.

8.2.2 *Customary Practices*—In instances where a customary machining procedure has been developed that is completely satisfactory for a class of materials (that is, it induces negligible surface/subsurface damage or residual stresses), this procedure may be used to machine the equibiaxial test specimens.

NOTE 7—Uniaxial surface grinding creates surface and subsurface microcracks, which may (or may not) be the strength-controlling flaws. Such machining cracks usually are oriented relative to the grinding direction and consequently may cause a pronounced variation in the uniaxial strength as a function of the test specimen orientation. If machining flaws dominate, equibiaxial test specimens will fail from the worst orientation and the measured equibiaxial strength will be representative of the machining damage. Further, the equibiaxial strength data may not correlate well with uniaxial data generated with standardized procedures that minimize the effects of such populations (8). Lapping or annealing can be used to minimize such effects in both equibiaxial strength tests and advanced ceramic components subjected to multiaxial stresses. Lapping needs to be sufficiently deep to remove machining damage (typically 10–30 μm deep). Note that surface finish is not a good indicator of the absence of machining damage.

8.2.3 *Recommended Procedure*—In instances where sections 8.2.1 or 8.2.2 are not appropriate sections 8.2.3.1–8.2.3.4 shall apply.

8.2.3.1 Perform all grinding or cutting with ample supply of appropriate filtered coolant to keep the specimen and grinding wheel constantly flooded and particles flushed. Grinding can be done in two stages, ranging from coarse to fine rates of material removal. All cutting can be done in one stage appropriate for the depth of cut.

8.2.3.2 The stock removal rate shall not exceed 0.03 mm per pass to the last 0.06 mm of material removed. Final finishing shall use diamond tools between 320 and 500 grit. No less than 0.06 mm shall be removed during the final finishing stage, and at a rate less than 0.002 mm per pass. Remove equal stock from opposite faces.

8.2.3.3 Grinding is followed by either annealing or lapping, as deemed appropriate.

NOTE 8—For alpha silicon carbide, annealing at ~1200°C in air for ~2 hours was sufficient to heal the grinding damage induced by the procedure in 8.2.3.2 without otherwise altering the material's strength (8). However, note that annealing can significantly alter a material's properties (9, 10), and specific procedures will need to be developed for each material.

NOTE 9—For lapping of alpha silicon carbide, the following procedure was successful in elimination of machining damage induced by uniaxial grinding: successive lapping with 15, 9 and 6 µm diamond pastes for ~30, ~25 and ~15 minutes respectively (11). Approximately 10 µm of materials was removed. For tungsten carbide, successive machine lapping with 15 and 6 µm diamond pastes for ~60 and ~30 minutes, respectively, with a pressure of ~13.8 kPa was sufficient (12). Specific procedures will need to be developed for other materials.

8.2.3.4 To aid in post failure fractographic examination, it is recommended that the orientation of the grinding direction be marked on the specimens. This can be accomplished with an indelible marker.

8.3 Test Specimen Preparation: As-Fabricated Specimens—In order to simulate the surface condition of an application in which no machining is used, limited testing of as-fabricated surfaces is allowed and precautions are recommended. The specimen should be flat to 0.1 mm in 25 mm. For test specimens exhibiting less flatness, it is suggested that the user consider Test Method F 394 or the use of fixturing designed to accommodate warped specimens (e.g. (13)). Data generated via this standard from specimens with flatness tolerance exceeding 0.1 mm in 25 mm should be noted as warped and used only for comparison and quality control purposes.

8.4 Edge Preparation—Edge failure can be minimized by using the machining practice described in section 8.2.3. Additional beveling or edge preparation is not necessary. However, for as-fabricated specimens exhibiting poor edge finish or for specimens made from materials that are particularly difficult to machine without chipping of the edges, edge related failures can be minimized by using the overhang described in Eq 2 or by beveling the specimen's tensile edge (that is, the edge of the face in contact with the support ring). If edge failures are a concern, it is recommended that the edge on the tensile face be inspected at ~30× magnification and any observed chips removed by beveling.

NOTE 10—For polycrystalline ceramics such as dense silicon carbides, silicon nitrides and aluminas, beveling can be accomplished by hand with 400-grit silicon carbide abrasive paper. Alternatively, a ~0.125 mm, 45° bevel can be ground onto the tensile edge according to the procedures in section 8.2.3. The grinding direction should be circumferential for circular specimens and parallel to the edges for square specimens. For softer materials or extremely strong materials, other methods may need to be developed.

8.5 Handling Precaution—Exercise care in storage and handling of test specimens to minimize the introduction of severe, extrinsic flaws. In addition, give attention to pre-test

storage of test specimens in controlled environments or desiccators to avoid unquantifiable environmental degradation of test specimens prior to testing.

8.6 Number of Test Specimens—A minimum of 10 specimens tested validly is required for the purpose of estimating a mean biaxial flexural strength. For the estimation of the Weibull parameters, a minimum of 30 test specimens validly tested is recommended. However, C 1239 should be consulted to determine if the resultant confidence intervals are adequate for the intended purpose. If material cost or test specimen availability limits the number of tests to be conducted, fewer tests may be conducted.

8.7 Valid Tests—A valid individual test is one that meets all the following requirements: (1) all the testing requirements of this test method, and (2) failure does not occur from the specimen edges. Those tests failing from flaws at the edges, while not valid, may be interpreted as interrupted tests for the purpose of censored test statistical analyses or as an indicator of edge condition.

9. Procedure

9.1 Test Specimen and Ring Dimensions—Measure the load and support ring diameters to within 0.2 % of D . Determine the test specimen diameter to 0.2 % of D by measuring at two radial positions nominally separated by 90°. For square specimens, determine the width l_1 and length l_2 to 0.2 % at the middle of the edges. Diameter measurements can be made with a digital caliper, optical device (e.g. machinists microscope) or a micrometer. In either case the resolution of the instrument shall be better than or equal to 0.01 mm. Measure the thickness to 0.5 % of h at the specimen center and at four equally spaced positions on a diameter nominally equal to that of the support ring. To avoid damage in the critical gage section area, use a flat, anvil-type micrometer to measure the thickness. Exercise extreme caution to prevent damage to the test specimen. Alternatively, if damage is a concern even with an anvil-type micrometer, measure the thickness at the four support diameter positions prior to the test for setup purposes and measure the thickness near the specimen center after the test. Record and report the measured dimensions. Use the average of the multiple measurements in the equibiaxial stress calculations.

9.1.1 Conduct inspection and measurements of all the test specimens and test specimen dimensions to assure compliance with the specifications of this test method.

9.1.2 Measurement of surface finish is not required; however, such information is desirable. Methods such as contacting profilometry can be used to determine surface roughness of the test specimen faces. If a contacting method is used, exercise caution to avoid causing surface damage to the test specimen. When quantified, report surface roughness and direction of the measurement with respect to the test specimen reference mark (section 8.2.3.4).

9.2 Test Modes and Rates:

9.2.1 General—Test modes and rates can have distinct influences on fracture behavior of advanced ceramics even at ambient temperatures. Test modes may involve load or displacement control. The recommended rates of testing are intended to be sufficiently rapid to nominally obtain the maximum equibiaxial strength at fracture of the material in the