

INTERNATIONAL STANDARD

**ISO
7864**

Second edition
1988-08-15



INTERNATIONAL ORGANIZATION FOR STANDARDIZATION
ORGANISATION INTERNATIONALE DE NORMALISATION
МЕЖДУНАРОДНАЯ ОРГАНИЗАЦИЯ ПО СТАНДАРТИЗАЦИИ

Sterile hypodermic needles for single use

Aiguilles hypodermiques stériles, non réutilisables

iTeh STANDARD PREVIEW
(standards.iteh.ai)

ISO 7864:1988

<https://standards.iteh.ai/catalog/standards/sist/57df2045-7898-4f0d-86f4-96ee055076cc/iso-7864-1988>

Foreword

ISO (the International Organization for Standardization) is a worldwide federation of national standards bodies (ISO member bodies). The work of preparing International Standards is normally carried out through ISO technical committees. Each member body interested in a subject for which a technical committee has been established has the right to be represented on that committee. International organizations, governmental and non-governmental, in liaison with ISO, also take part in the work. ISO collaborates closely with the International Electrotechnical Commission (IEC) on all matters of electrotechnical standardization.

Draft International Standards adopted by the technical committees are circulated to the member bodies for approval before their acceptance as International Standards by the ISO Council. They are approved in accordance with ISO procedures requiring at least 75 % approval by the member bodies voting.

International Standard ISO 7864 was prepared by Technical Committee ISO/TC 84, *Syringes for medical use and needles for injections*.

This second edition cancels and replaces the first edition (ISO 7864 : 1984), of which it constitutes a minor revision (re-designation of the needle length, addition of new tolerances on the needle length, and correction of error in B.1.2 as regards the International Standard referenced for aspiration testing).

Users should note that all International Standards undergo revision from time to time and that any reference made herein to any other International Standard implies its latest edition, unless otherwise stated.

Contents

	Page
0 Introduction	1
1 Scope and field of application	1
2 References	1
3 Nomenclature	1
4 Materials	2
5 Manufacture	2
6 Freedom from pyrogenic materials	2
7 Test for abnormal toxicity	2
8 Freedom from extraneous matter	2
9 Limits for extractable matter	2
10 Lubrication of hypodermic needles	3
11 Size designation	3
12 Range of sizes	3
13 Needle hub	3
14 Sheath	3
15 Needle tube	3
16 Test requirements for needle assembly	4
17 Packaging	5
18 Sterility	5
19 Marking of containers	5
Annexes	
A Preparation of extracts	6
B Testing of conical fitting for integrity of needle assembly on aspiration	6
C Resistance to corrosion	7
D Test for resistance of needle tubes to breakage	7

iTeh STANDARD PREVIEW
(standards.iteh.ai)

ISO 7864:1988

<https://standards.iteh.ai/catalog/standards/sist/57df2045-7898-4f0d-86f4-96ee055076ec/iso-7864-1988>

Sterile hypodermic needles for single use

0 Introduction

This International Standard deals with products primarily intended for use with humans and provides performance requirements, but permits some variation of design and of methods of packaging and sterilization by individual manufacturers.

Materials to be used for the construction of hubs for sterile needles for single use are not specified in detail as their selection will depend to some extent upon the design, process of manufacture and method of sterilization employed by individual manufacturers. The materials should be compatible with injection fluids included in relevant pharmacopoeias.

The majority of injections are in aqueous media. Such media are not known to give problems. It is usual for non-aqueous injections to be formulated in either ester type solvent or the active ingredient itself may be fluid.

Tests for freedom from pyrogenic material, abnormal toxicity and certain chemical tests for extractable material are included in clauses 6, 7 and 9 respectively.

Annexes A, B, C and D form an integral part of this International Standard.

In some countries national pharmacopoeias or other government regulations are legally binding and their requirements may take precedence over this International Standard.

Hypodermic needles specified in this International Standard are intended for use with hypodermic syringes specified in

ISO 595¹⁾ and ISO 7886. The 6 % taper conical fitting (Luer) specified is in conformity with ISO 594.

1 Scope and field of application

This International Standard specifies requirements for sterile hypodermic needles for single use.

2 References

ISO 594, *Conical fitting with a 6 % (Luer) taper for syringes, needles and certain other medical equipment* —

Part 1 : General requirements.

*Part 2 : Lock fittings.*²⁾

ISO 6009, *Hypodermic needles for single use — Colour coding for identification.*

ISO 7886, *Sterile hypodermic syringes for single use.*

3 Nomenclature

The nomenclature of components of hypodermic needles for single use is illustrated in the figure.

1) ISO 595, *Reusable all-glass or metal-and-glass syringes for medical use* —

Part 1 : Dimensions.

Part 2 : Design, performance requirements and tests.

2) At present at the stage of draft. (Revision, in part, of ISO/R 594 : 1967.)

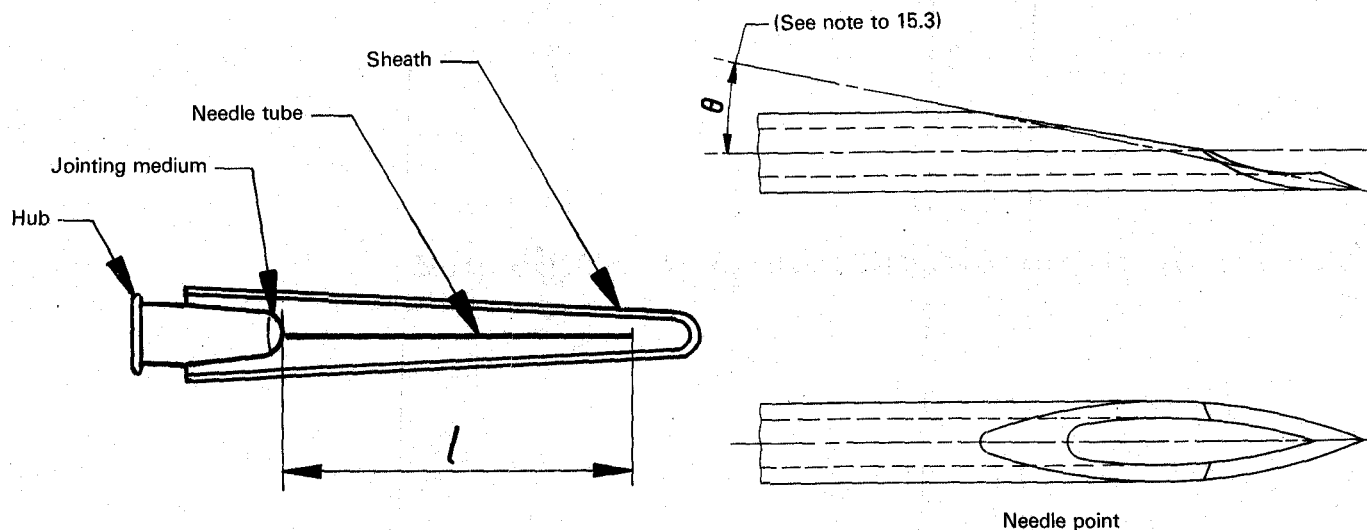

NOTE — The drawing is intended to illustrate the nomenclature of a typical hypodermic needle, but does not otherwise form part of the specification.

Figure — Typical hypodermic needle for single use

iTeh STANDARD PREVIEW
(standards.iteh.ai)

4 Materials

4.1 Materials used in the manufacture of hypodermic needles shall be suitable for their intended use and the process to be used for sterilization.

4.2 Materials used in the manufacture of hypodermic needles shall not cause them to be detrimentally affected, physically or chemically, by the normal use of injectable preparations.

4.3 Materials used in the manufacture of hypodermic needles shall not cause them to yield, under conditions of normal use, significant amounts of toxic substances and shall permit them to satisfy the requirements for freedom from pyrogenic materials (see clause 6), abnormal toxicity (see clause 7) and tests for extractable matter (see clause 9).

5 Manufacture

Hypodermic needles shall be manufactured in accordance with recognized national or international codes of good manufacturing practice and shall be substantially free from defects affecting appearance, safety and serviceability for the intended use.

6 Freedom from pyrogenic materials

Hypodermic needles shall be capable of satisfying the test for freedom from pyrogenic materials in accordance with the relevant national pharmacopoeia.

The extract to be used in the test shall be prepared as described in clause A.2.

7 Test for abnormal toxicity

Hypodermic needles shall be capable of satisfying the test for abnormal toxicity specified in the relevant national pharmacopoeia.

The extract to be used in the test shall be prepared as described in clause A.2.

8 Freedom from extraneous matter

The surface of the hypodermic needle shall be clean and free from extraneous matter when viewed by normal or corrected vision without magnification.

9 Limits for extractable matter

9.1 General

Hypodermic needles shall be capable of satisfying the chemical tests for extractable matter in accordance with the relevant national pharmacopoeia.

9.2 Limits for acidity or alkalinity

The pH-value of the needle extract, prepared as described in clause A.3, shall be determined with a laboratory potentiometric pH-meter and using a general purpose electrode, and shall be within one unit of pH of that of the control fluid.

9.3 Limits for extractable metals

An extract, prepared as described in clause A.3, shall contain not more than a combined total of 5mg/kg of lead, tin, zinc and

iron when tested in accordance with a recognized micro-analytical method, e.g. an atomic absorption method. The cadmium content of the extract shall be less than 0,1 mg/kg.

10 Lubrication of hypodermic needles

10.1 If the external surface of the hypodermic needle tube is lubricated, the lubricant shall not adversely affect compliance with the requirements of clause 4.

10.2 The quantity of lubricant used shall be minimal and shall not be visible as drops of fluid on the exterior surface of the hypodermic needle tube or in the bore.

11 Size designation

The size of hypodermic needle shall be designated by the following :

- a) nominal external diameter of needle tube, expressed in millimetres;
- b) nominal length of needle, expressed in millimetres.

The size shall be expressed, in millimetres, in accordance with the following example :

0,8 × 40

NOTE — If the needle is made of thin-walled tubing, this may be stated.

12 Range of sizes

The diameter of hypodermic needles shall be in accordance with table 1.

The preferred range of nominal lengths of hypodermic needles shall be in accordance with table 1.

The nominal diameter of hypodermic needles shall be identified by colour coding in accordance with ISO 6009 and as shown in table 1, applied to the unit container and/or part of the needle assembly such as the needle hub or the sheath.

Table 1 — Range of needle sizes and colour code

Dimensions in millimetres

Nominal external diameter	Colour coding in accordance with ISO 6009	Preferred nominal length of needle tube					
		12	16	25	30	40	50
0,45	Brown	x					
0,5	Orange	x	x				
0,6	Deep blue			x	x		
0,7	Black			x	x	x	
0,8	Deep green			x	x	x	x
0,9	Yellow			x		x	
1,1	Cream			x	x	x	x
1,1 (thin-walled)	Cream					x	
1,2	Pink					x	

13 Needle hub

13.1 Conical fitting

The conical socket of the hypodermic needle hub shall comply with the requirements of ISO 594.

When mated with a reference steel male conical fitting in accordance with ISO 594-1, the socket shall make a leakproof union when subjected to the test described in annex B.

13.2 Colour of hub

The hub shall be made either of pigmented or of unpigmented material. If pigmented, the colour shall be in accordance with clause 12.

13.3 Finish

The surface of the hub shall be free from functional defects and substantially free from visual defects.

When examined under X2,5 magnification with adequate illumination, the hub socket shall be free from particles and other extraneous matter.

14 Sheath

If a separate needle sheath is provided, it shall be made of either pigmented or unpigmented material. If pigmented, the colour shall be in accordance with clause 12.

15 Needle tube

15.1 Material

The needle tube shall be made from austenitic stainless steel having properties capable of satisfying the tests for mechanical strength and corrosion resistance in 15.5, 15.6 and 15.7.

NOTE — Suitable needle tubing may be manufactured from steel the composition of which is in accordance with ISO 683-13¹⁾, types 10, 11, 16, 20, 21 and 23.

15.2 Dimensions of needle tube

The external diameter and minimum bore of the needle tube shall be as given in table 2.

The length, *l*, of the needle tube shall be as given in table 3.

1) ISO 683-13, Heat-treatable steels, alloy steels and free-cutting steels — Part 13 : Wrought stainless steels.

Table 2 — Diameter of needle tube

Dimensions in millimetres

Nominal external diameter	External diameter		Bore of needle min.
	min.	max.	
0,45	0,44	0,47	0,24
0,5	0,5	0,53	0,24
0,6	0,62	0,65	0,32
0,7	0,7	0,73	0,39
0,8	0,8	0,83	0,49
0,9	0,86	0,92	0,56
1,1	1,03	1,1	0,65
1,1 (thin-walled)	1,03	1,1	0,79
1,2	1,21	1,3	0,79

Table 3 — Length of needle tube

Dimensions in millimetres

Nominal length	Length <i>l</i>
12	12 +1 -2
16	16 +1 -2
25	25 +1,5 -2,5
30	30 +1,5 -2,5
40	38,5 +1,5 -2,5
50	50 +1,5 -2,5

15.3 Needle point

The needle point shall be sharp, free from feather edges, burrs, hooks and other defects.

NOTE — The needle point, as illustrated by the angle shown in the figure, usually has a bevel with an angle of $12^\circ \pm 2^\circ$. Alternatively a "short" bevel with an angle of $18^\circ \pm 2^\circ$ or other nominal angle subject to a tolerance of $\pm 2^\circ$ may be supplied.

15.4 Freedom from defects

The needle tube shall be straight, of regular cross-section and wall thickness and free from manufacturing defects. The external surface of the tube shall be smooth.

15.5 Resistance to corrosion

The needle tube shall not show corrosion when tested in accordance with the procedure given in annex C.

15.6 Stiffness

The needle tube, after removal of the hub if necessary, shall not show a deflection greater than that given for the appropriate nominal diameter when loaded centrally between two supports under the conditions defined in table 4.

Table 4 — Stiffness test

Nominal external diameter mm	Span mm	Load	Maximum deflection
		N	mm
0,45	10	6	0,56
0,5	10	7	0,38
0,6	12,5	15	0,59
0,7	15	15	0,61
0,8	15	15	0,41
0,9	17,5	15	0,48
1,1	25	20	0,84
1,1 (thin-walled)	25	10	0,65
1,2	25	20	0,45

15.7 Resistance to breakage

When tested in accordance with the method given in annex D, the needle tube shall withstand 20 complete cycles of reversal of force without breaking.

16 Test requirements for needle assembly

16.1 Bond between hub and needle tube

The union of the hub and needle tube shall not be broken by a force of the magnitude given in table 5 applied as push or pull in the direction of the axis of the needle.

Table 5 — Bond between hub and needle tube

Nominal external diameter mm	Force N
0,45	22
0,5	22
0,6	34
0,7	40
0,8	44
0,9	54
1,1	69
1,1 (thin-walled)	69
1,2	69

16.2 Patency of lumen

A stainless steel stylet of the appropriate diameter selected from table 6 shall pass through the needle.

Alternatively, the lumen shall satisfy a water flow rate test in which the flow rate shall be not less than 80 % of that of a needle of equivalent diameter and length with a minimum bore in accordance with table 2. The water pressure during the test shall not exceed 1×10^5 Pa (≈ 1 atm).

Table 6 — Size of stylet to test patency of lumen

Dimensions in millimetres

Nominal external diameter	Diameter of stylet
0,45	0,18
0,5	0,18
0,6	0,25
0,7	0,3
0,8	0,4
0,9	0,48
1,1	0,58
1,1 (thin-walled)	0,7
1,2	0,7

17 Packaging

17.1 Unit container

Each hypodermic needle shall be sealed in a unit container. The material and design of this container shall be such as to ensure

- a) visible colour coding to denote nominal external diameter of the needle tube in accordance with the requirements of table 1;
- b) maintenance of sterility of the contents under dry, clean and adequately ventilated storage conditions;
- c) minimum risk of contamination of the contents during removal from the container;
- d) adequate protection of the contents during normal handling, transit and storage.

17.2 Outer container

A convenient number of unit containers shall be packaged in an outer container which shall be sufficiently robust to protect the contents during handling, transit and storage.

18 Sterility

The contents of the unit container (see 17.1) shall be sterile.

NOTE — National regulatory authorities in many countries may require conformance with pharmacopoeia tests or national regulations.

19 Marking of containers

19.1 Unit container

The unit container shall be marked to include the following :

- a) description of contents, including the size designated in accordance with clause 11;
- b) the word "STERILE";
- c) the name and/or trade-mark of the manufacturer or supplier;
- d) an identification reference to the batch or the date of manufacture.

19.2 Outer container

Outer containers shall be marked to include the following :

- a) description of contents, including the size designated in accordance with clause 11, the type or angle of bevel (see 15.3) and the word "STERILE";
- b) the words "FOR SINGLE USE" or equivalent;

NOTE — Use of the term "disposable" is not acceptable.

- c) warning to check the integrity of each unit container;
- d) identification reference to the batch [to accord with 19.1d)] and date (month and year) of sterilization;
- e) the manufacturer's or supplier's name and address.

iTeh STANDARD PREVIEW
(standards.iteh.ai)

ISO 7864:1988

https://standards.iteh.ai/catalog/standards/sist/57d2045-7898-4f0d-86f1-96ee055076ec/iso-7864-1988