



Designation: C 4 – 02

## Standard Specification for Clay Drain Tile and Perforated Clay Drain Tile<sup>1</sup>

This standard is issued under the fixed designation C 4; the number immediately following the designation indicates the year of original adoption or, in the case of revision, the year of last revision. A number in parentheses indicates the year of last reapproval. A superscript epsilon ( $\epsilon$ ) indicates an editorial change since the last revision or reapproval.

*This standard has been approved for use by agencies of the Department of Defense.*

### 1. Scope

1.1 This specification establishes the criteria for acceptance, prior to installation, of drain tile and perforated drain tile to be used for underdrainage, filter fields, leaching fields, and similar subdrainage installations.

1.2 The values stated in inch-pound units are to be regarded as the standard. The values given in parentheses are for information only.

1.3 The following safety hazards caveat pertains only to the Test Methods portion of this specification: *This standard does not purport to address all of the safety concerns, if any, associated with its use. It is the responsibility of the user of this standard to establish appropriate safety and health practices and determine the applicability of regulatory limitations prior to use.*

NOTE 1—Attention is called to Test Methods C 301 and Terminology C 896.

### 2. Referenced Documents

2.1 *ASTM Standards:*

C 301 Test Methods for Vitrified Clay Pipe<sup>2</sup>

C 896 Terminology Relating to Clay Products<sup>2</sup>

### 3. Terminology

3.1 *Definitions:*

3.1.1 *Clay, fire clay, shale, and surface clay* are as defined in Terminology C 896.

3.1.2 Within this specification, the terms *tile, drain tile, and clay drain tile* are synonyms.

### 4. Classification

4.1 Four classes of clay drain tile are specified:

4.1.1 Standard.

4.1.2 Extra Quality.

4.1.3 Heavy Duty.

4.1.4 Extra Strength.

4.2 Drain tile of a higher strength classification than that

specified by the purchaser may be furnished by the seller, provided the substituted drain tile meets the physical requirements of the class specified.

### 5. Materials and Manufacture

5.1 Drain tile shall be manufactured from clay, fire clay, shale, surface clay, or a combination of these materials, that, when formed into tile and fired to suitable temperatures, yields a product that conforms to this specification.

### 6. Physical Properties

6.1 Drain tile shall meet the physical test requirements for the class, as specified in Table 1.

6.2 The maximum water absorption (5-h boiling) shall be as follows:

	Average, %	Individual, %
Standard	13	16
Extra Quality	11	13
Heavy Duty	11	13
Extra Strength	11	13

6.3 The requirements for water absorption (5-h boiling) shall be waived, provided that test specimens meet the requirements of the freezing and thawing test, Section 13, of this specification

### 7. Sizes and Perforations

7.1 The size of drain tile shall be designated by inside diameter. Not all sizes and strengths may be available from all manufacturers.

7.2 The minimum length of drain tile smaller than 12 in. (305 mm) shall be approximately 12 in.

7.3 The length of drain tile 12 through 30-in. (305 through 760-mm) diameter shall be not less than their diameter.

7.4 *Perforations*—Perforations shall be circular and cleanly cut through the tile wall. They shall be arranged in rows parallel to the longitudinal axis of the tile. The minimum number of rows of perforations shall be as shown in Table 2.

7.4.1 Where two rows of perforations are used, the rows shall be separated by an arc of  $90 \pm 15^\circ$ .

7.4.2 Where four rows of perforations are used, the rows shall be symmetrical around a vertical centerline. The lower-most rows of perforations shall be separated by an arc of  $90 \pm 10^\circ$ , and the uppermost rows shall be separated by an arc of not over  $160^\circ$  measured around the lower part of the tile (Fig. 1).

<sup>1</sup> This specification is under the jurisdiction of ASTM Committee C04 on Vitrified Clay Pipe and is the direct responsibility of Subcommittee C04.20 on Methods of Test and Specifications.

Current edition approved Jan. 10, 2002. Published February 2002. Originally published as C 4–14. Last previous edition C 4–00.

<sup>2</sup> *Annual Book of ASTM Standards*, Vol 04.05.



**TABLE 1 Physical Test Requirements for Clay Drain Tile**

Internal Diameter of Tile, in.	Standard		Extra Quality		Heavy Duty		Extra Strength	
	Minimum Crushing Strength, <sup>A</sup> lbf/linear ft (kN/m)		Minimum Crushing Strength, <sup>A</sup> lbf/linear ft (kN/m)		Minimum Crushing Strength, <sup>A</sup> lbf/linear ft (kN/m)		Minimum Crushing Strength, <sup>A</sup> lbf/linear ft (kN/m)	
	Average	Individual	Average	Individual	Average	Individual	Average	Individual
3½	800 (11.7)	680 (9.9)	1100 (16.0)	990 (14.5)	1400 (20.4)	1260 (18.4)	2000 (29.2)	1800 (26.3)
4	800 (11.7)	680 (9.9)	1100 (16.0)	990 (14.5)	1400 (20.4)	1260 (18.4)	2000 (29.2)	1800 (26.3)
5	800 (11.7)	680 (9.9)	1100 (16.0)	990 (14.5)	1400 (20.4)	1260 (18.4)	2000 (29.2)	1800 (26.3)
6	800 (11.7)	680 (9.9)	1100 (16.0)	990 (14.5)	1400 (20.4)	1260 (18.4)	2000 (29.2)	1800 (26.3)
8	800 (11.7)	680 (9.9)	1100 (16.0)	990 (14.5)	1500 (21.9)	1350 (19.7)	2140 (31.2)	1920 (28.0)
10	800 (11.7)	680 (9.9)	1100 (16.0)	990 (14.5)	1550 (22.6)	1400 (20.4)	2200 (32.1)	1980 (28.9)
12	800 (11.7)	680 (9.9)	1100 (16.0)	990 (14.5)	1700 (24.8)	1530 (22.3)	2420 (35.3)	2170 (31.7)
14	840 (12.3)	720 (10.5)	1100 (16.0)	990 (14.5)	1850 (27.0)	1660 (24.2)	2640 (38.5)	2370 (34.6)
15	870 (12.7)	740 (10.8)	1150 (16.8)	1030 (15.0)	1980 (28.9)	1780 (26.0)	2800 (40.9)	2620 (38.3)
16	...	...	1200 (17.5)	1080 (15.8)	2100 (30.7)	1890 (27.6)	3000 (43.8)	2700 (39.4)
18	...	...	1300 (19.0)	1170 (17.1)	2340 (34.2)	2100 (30.7)	3300 (48.2)	2970 (43.4)
21	...	...	1450 (21.2)	1300 (19.0)	2680 (39.1)	2410 (35.2)	...	...
24	...	...	1600 (23.4)	1440 (21.0)	3000 (43.8)	2700 (39.4)	...	...
27	...	...	1800 (26.3)	1620 (23.7)	3330 (48.6)	3000 (43.8)	...	...
30	...	...	2000 (29.2)	1800 (26.3)	3590 (52.4)	3230 (47.2)	...	...

<sup>A</sup> Strengths of sizes not listed may be interpolated between tabular values of sizes and strengths of the nearest listed diameters.

**TABLE 2 Number of Perforations per Row for Perforated Clay Drain Tile**

Tile Size Diameter, in. (mm)	Minimum Number of Rows of Perforations	Nominal Lengths of Tile, ft (m)				
		1 (0.30)	1½ (0.46)	2 (0.60)	2½ (0.76)	3 (0.91)
		Minimum Number of Perforations per Row				
3½, 4, 5, 6 (100, 125, 150)	4	3	5	7	9	11
3½, 4, 5, 6 (100, 125, 150)	2	5	8	11	13	15
8, 10, 12 (205, 255, 305)	4	3	5	7	9	11
14 to 18 (355 to 455)	6	...	5	7	9	11

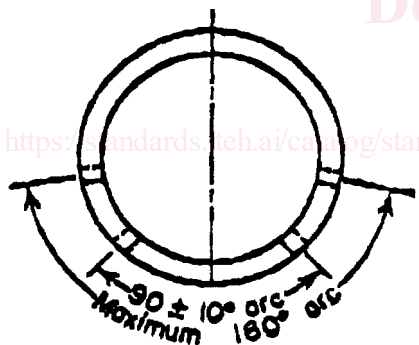

**FIG. 1 Spacing of Four Rows of Perforations**

8.3.1 The ends of plain-end tile shall be sufficiently square as to make close joints.

### 9. Sampling and Testing

9.1 Tile shall be sampled and tested in accordance with Sections 11 through 13.

9.2 For test purposes, full-size drain tile shall be selected by the purchaser or his authorized representative. Tile shall be representative of the lot from which they are selected. The place or places of selection shall be designated when the purchase order is issued. The manufacturer or seller shall furnish test tile without charge.

9.3 Each tile shall be individually marked so that it is identifiable within the testing period.

### 10. Basis of Acceptance

10.1 Acceptability of nonperforated drain tile is determined by compliance with the requirements of Table 1, Table 3, and the inspection requirements of Section 14.

10.2 Acceptability of perforated drain tile is determined by compliance with the requirements of Tables 1-3 and the inspection requirements of Section 14.

### TEST METHODS

#### 11. Crushing Strength Test

11.1 *Test Samples:*

11.1.1 Test tile shall be sound, full size, and selected by the purchaser or his representative.

7.4.3 If more than four rows of perforations are used, the spacing of rows shall be uniform between the limits in 7.4.2.

7.4.4 The purchaser shall specify the desired perforation diameter option of: (1) ¼ ± 1/16 in. (6.4 ± 1.6 mm) or (2) ½ ± 1/8 in. (12.7 ± 3.2 mm), and the number of rows of perforations.

7.4.5 Perforations shall not be spaced more than approximately 3 in. (75 mm) center-to-center along the rows.

### 8. Workmanship and Finish

8.1 Drain tile shall be free of cracks, checks, or chips that decrease the strength.

8.2 Drain tile shall conform to the permissible dimensional variations in Table 3.

8.3 Plain-end tile shall be furnished unless otherwise specified by the purchaser.

**TABLE 3 Permissible Variations in Dimensions**

Physical Properties Specified	Standard	Extra Quality, Heavy Duty, and Extra Strength
Permissible variation of average diameter below specified diameter, %	3	3
Permissible variation between maximum and minimum diameters of same tile, percentage of wall thickness	75	65
Permissible variation of average length of tile sampled below manufacturer's specified length, %	3	3
Permissible variation from straightness, percentage of length	3	3
Permissible thickness of exterior blisters, lumps, and flakes, percentage of wall thickness	20	15
Permissible diameters of blisters, lumps, and flakes, percent of inside diameter	15	10

11.1.2 The number of tile to be tested shall not exceed 0.5 % of the number of tile of each size furnished, except that no less than five tile of each size shall be tested.

11.2 *Loading Apparatus (see Fig. 2):*

11.2.1 *Testing Machine:*

11.2.1.1 The loading apparatus may consist of any mechanically driven or hand-powered device that is capable of applying the necessary loads, with upper and lower bearings capable of transmitting these loads to the tile. The bearings shall be bearing beams and contact edges.

11.2.1.2 Any device that is capable of applying a load at a uniform rate, from 500 to 2000 lbf/linear ft-min (7300 to 29 200 N/linear m-min) of tile length, may be used for making the test.

11.2.1.3 The testing machine shall be sufficiently rigid so that the load distribution will not be appreciably affected by the deformation or yielding of any part. The machine and bearings shall be constructed to transmit the load in a vertical plane through the longitudinal axes of the bearings and tile. The bearings shall be attached to the machine so as to receive and uniformly transmit the loads required in the tests, without vibration or shock.

11.2.1.4 The loading apparatus shall provide means for determination of load with an accuracy of at least 98 % and capable of retaining the loading information that results in the crushing strength determination.

11.2.2 *Bearing Beams*—Bearing beams shall be no less than the length of the barrel of the tile. Built-up bearing beams may be used, provided their deflection does not exceed that specified. In order for the bell or socket of the tile, if applicable, to clear the bearing beams, it is recommended that the bearing beams be faced with a metal or hardwood member for affixing the contact edges.

11.2.3 *Three-Edge Bearings:*

11.2.3.1 Three-edge bearings shall consist of an upper member, comprised of a bearing beam on which one contact edge is located so that it lies in the vertical plane passing through the longitudinal axis of the tile, and a lower member comprised of a bearing beam on which two contact edges are symmetrically located parallel to that vertical plane.

11.2.3.2 The contact edges shall consist of rubber strips alone or hardwood strips with plaster of paris fillets. Contact edges shall uniformly contact the outside of the tile.

11.2.3.3 The two contact edges on the lower member shall be spaced apart approximately 1 in./ft (25 mm/m) of tile diameter, but in no case less than 1 in. (25 mm).

11.2.3.4 Positioning strips may be used to align the upper contact edge and to align and space the lower contact edges. In

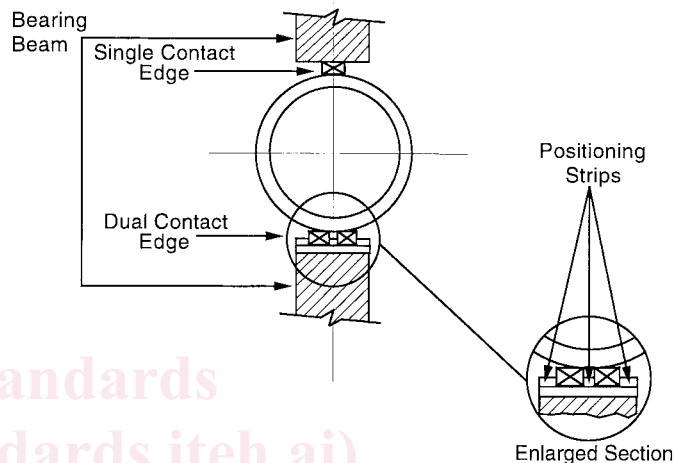

**FIG. 2 Loading Apparatus**

the case of rubber contact edges, positioning strips shall not exceed one half of the thickness of the contact edge and may remain in place.

11.2.3.5 If rubber strips are used as contact edges, they shall be cut or formed from a material having a Shore A, instantaneous, durometer hardness between 45 and 60. The strips shall be of rectangular cross section, having a 2-in. (50-mm) width, and a thickness not less than 1 in. (25 mm) nor more than 1½ in. (38 mm). The contact edges shall be used with the 2-in. dimension in contact with the bearing beam. Rubber contact edges may be attached to the bearing beam by an adhesive, provided the contact edge remains firmly fixed in position.

11.2.3.6 If hardwood strips with plaster of paris fillets are used as contact edges, the strips shall be straight and have a cross section not less than 1 in. (25 mm) in either direction. The bottom contact edges shall have vertical sides, with the interior top corners having a radius of approximately ½ in. (13 mm). The contact edges shall be securely fastened to the beams.

11.2.3.7 Plaster of paris fillets shall be cast on hardwood contact edges to provide uniform bearing contact on the outside of the tile. Fillets shall be cast on the two lower contact edges and on the upper contact edge, along the tile crown. Sufficient excess plaster shall be removed from between the two lower contact edges to eliminate the possibility of a single continuous lower contact. The tile and contact edges shall be joined while the plaster of paris is still workable. Testing shall be performed only after the fillets have set.

11.3 *Procedure:*

11.3.1 Immerse tile, 12-in. (305-mm) diameter and smaller,