

# INTERNATIONAL STANDARD

ISO  
7892

First edition  
1988-08-01



---

INTERNATIONAL ORGANIZATION FOR STANDARDIZATION  
ORGANISATION INTERNATIONALE DE NORMALISATION  
МЕЖДУНАРОДНАЯ ОРГАНИЗАЦИЯ ПО СТАНДАРТИЗАЦИИ

---

## Vertical building elements — Impact resistance tests — Impact bodies and general test procedures

**iTeh STANDARD PREVIEW**  
*Ouvrages verticaux des constructions — Essais de résistance aux chocs — Corps de chocs et modalités des essais de choc*  
**(standards.iteh.ai)**

[ISO 7892:1988](#)

<https://standards.iteh.ai/catalog/standards/sist/0c601417-d464-4ba5-b828-4410535aadee/iso-7892-1988>

Reference number  
ISO 7892:1988 (E)

## Foreword

ISO (the International Organization for Standardization) is a worldwide federation of national standards bodies (ISO member bodies). The work of preparing International Standards is normally carried out through ISO technical committees. Each member body interested in a subject for which a technical committee has been established has the right to be represented on that committee. International organizations, governmental and non-governmental, in liaison with ISO, also take part in the work. ISO collaborates closely with the International Electrotechnical Commission (IEC) on all matters of electrotechnical standardization.

Draft International Standards adopted by the technical committees are circulated to the member bodies for approval before their acceptance as International Standards by the ISO Council. They are approved in accordance with ISO procedures requiring at least 75 % approval by the member bodies voting.

International Standard ISO 7892 was prepared by Technical Committee ISO/TC 59, *Building construction*.

[ISO 7892:1988](#)

Users should note that all International Standards undergo revision from time to time and that any reference made herein to any other International Standard implies its latest edition, unless otherwise stated.

# Vertical building elements — Impact resistance tests — Impact bodies and general test procedures

## 0 Introduction

**0.1** This International Standard is one of a series of standards relating to the performance of building elements.

This series comprises firstly

- performance standards which indicate the type of performance characterizing each family of elements — façades, partitions, roofs, cross-walls, tridimensional units — making up a building with their scales of values, if required, and which also refer to suitable methods for determining performance,
- and, secondly, International Standards applicable to each family of elements, describing the means (measurement, calculation, test method or method of examination) by which a certain performance achieved by the element is to be evaluated or verified, and/or the means of forecasting the life expectancy.

In conjunction with this series of standards, another series will also be established defining the rules pertaining to dimensional coordination and modular coordination for the different families of elements, given that they and performance are so related that some correlation is desirable.

**0.2** The vertical walls of buildings may be subject to different types of impact as described below :

- impacts from small hard bodies, for example, corresponding to impact from a stone thrown from the outside or to impact from the corner of a piece of furniture on the inside,
- exceptional impacts from the inside, for example, corresponding to impacts from men, animals or deformable objects against walls, acting on a small area,
- exceptional impacts from the outside, for example, corresponding to projections of men or animals against the façades, their whole mass acting on a large impact area.

## 1 Scope and field of application

This International Standard defines

- the conventional impact bodies used in order to reproduce the effect of actual impacts on vertical building elements,
- the general test procedures, the test procedures specific to each type of building element tested being given in the standards specific to these building elements.

It applies to all vertical (or nearly vertical) building elements, excluding doorsets for which a method is specified in ISO 8270.<sup>1)</sup>

The impacts used for verifying a property of the material, often specific to the character of this material, are defined in the standards dealing with these materials.

The impacts used in order to create shock effects in particular types of walls are not dealt with in this International Standard.

The specifications particular to each type of building element (impact energy, location and number of impacts, etc.) as well as the criteria for the assessment of the results are given in the test and performance standards dealing with these building elements.

## 2 Types of impacts

The three types of conventional impacts to be applied are as follows.

NOTE — The impacts arising from an object moving at high speed (such as firearm projectiles, hail) are not considered in this International Standard.

### 2.1 Impacts from hard bodies

These represent in particular impacts resulting from the displacement or the projection of non-deformable objects (for example, displacement of a piece of furniture or throwing of a stone).

1) ISO 8270, *Doorsets — Soft heavy body impact test*.

## 2.2 Impacts from small soft bodies

These represent in particular the impact of a human body on a small impact area (for example, blow from fist or knee) as well as the impacts resulting from the displacement or projection of small deformable objects (for example, a football).

## 2.3 Impacts from large soft bodies

These represent in particular the impact of a human body on a large impact area (for example, blow from shoulder, fall).

## 3 Definition of impact bodies

### 3.1 Hard bodies

**3.1.1** Hard bodies are plain steel ball-bearings (available from manufacturers of ball-bearings).

**3.1.2** The one termed a "500 g steel ball-bearing" has a diameter of 50 mm; to it may be fixed a link-bolt; its mass shall be  $500 \pm 5$  g.

**3.1.3** The other termed a "1 kg steel ball-bearing" has a diameter of 62,5 mm; to it may be fixed a link-bolt; its mass shall be  $1\ 000 \pm 10$  g.

### 3.2 Small soft bodies

**3.2.1** The small soft body is a ball weighing 3 kg (see figure 1).

**3.2.2** This is a spherical ball with a diameter of 100 mm, comprising a 1,5 mm thick envelope made of flexible rubber with a canvas reinforcement.

**3.2.3** In the skin of this ball are two holes : the one on the upper pole is 15 mm, the other on the lower pole is 5 mm.

**3.2.4** An expandable ring-bolt of 4 mm diameter is inserted through the 15 mm diameter hole, the expansion being obtained by means of a wing nut expandable by the action of a spring.

The straight part of the threaded bolt of 4 mm diameter shall have a length of about 120 mm so that it protrudes by 20 mm from the 5 mm diameter hole when the bolt is in place.

On this protruding end is placed a wide cap-shaped flange of 25 mm diameter, held against the skin of the ball by means of a tight nut. The purpose of this flange is to assist in sustaining the mass of the ball after it has been filled, thus avoiding the elongation of the envelope, which would occur if it were simply suspended.

The tightness of the 15 mm diameter hole is obtained by means of a 25 mm diameter flange identical to the preceding one placed between the skin and the ring of the bolt.

**3.2.5** The two nuts (lifting and expandable wing-nut) are sufficiently loosened to give access to the 15 mm diameter hole, through which a mixture with a particle size of 0/2 mm, composed of fine sand and lead shot is poured.

**3.2.6** The bag shall be filled until it weighs 3 kg, taking into account the mass of the ball and the bolt. The proportions of sand/lead shot shall be such that this mass  $\pm 0,03$  kg means that the bag is nearly full.

**3.2.7** After filling the bag, the nuts are correctly tightened and the lifting nut is fixed in position by means of a lock-nut.

### 3.3 Large soft impact bodies

**3.3.1** The large soft impact body is a spheroconical bag having a mass of 50 kg (see figure 2).

**3.3.2** This spheroconical bag is made of eight sections of tarpaulin sewn together.

**3.3.3** The dimensions of the bag when filled are those of a volume composed of a sphere of 400 mm diameter inscribed in a cone, the top of which is located at a distance of 400 mm from the centre of the sphere.

**3.3.4** The bottom of the bag is strengthened by a circular piece of leather of 120 mm diameter sewn onto it.

**3.3.5** The top of the bag is slightly truncated in order to make an opening of 80 mm diameter. This opening is strengthened by a leather strip sewn onto the bag, to which are fixed four equidistant rings held together by a suspension ring.

**3.3.6** The bag is filled with hardened glass marbles of 3 mm diameter (usually used for grinding paint); its mass is  $50 \pm 0,5$  kg.

**3.3.7** In order to prevent marbles spilling out if the seams burst, it is advised to line the bag with a heavy-duty polyethylene bag.

## 4 General test procedures

### 4.1 Principle of tests

The impact tests consist in the impact body falling pendularly onto the specimen arranged in position in a frame. In case of rebound the impact body shall be held back to avoid a second impact.

### 4.2 Test equipment

The test equipment representing the structure in which the building element is to be fixed shall reproduce actual conditions of support and shall be designed so that the energy absorbed by the building element on impact is not modified. To this end the element and its anchorages shall be such that the displacements of the fixing points are less than 0,1 mm when the element is submitted to impact.

Dimensions in millimetres

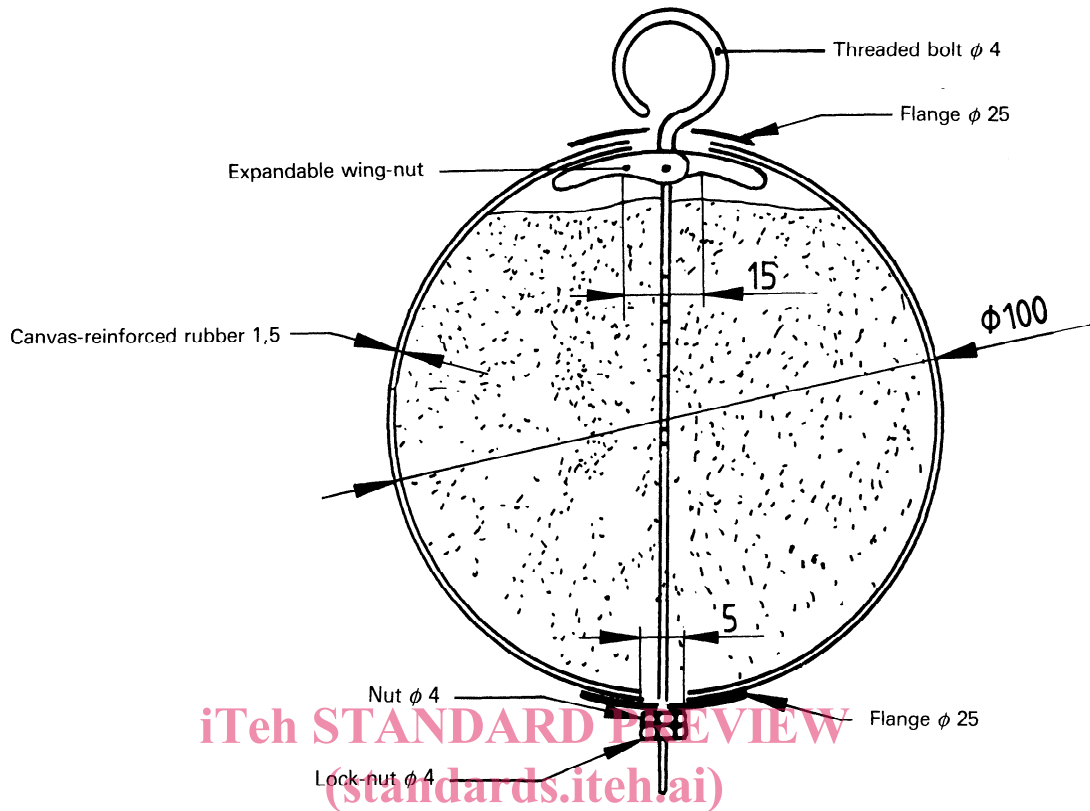

ISO 7892:1988  
<https://standards.iteh.ai/catalog/standards/sist/c601417-d464-4ba5-b828-4410535aadee/iso-7892-1988>  
 Figure 1 — 3 kg ball

Dimensions in millimetres

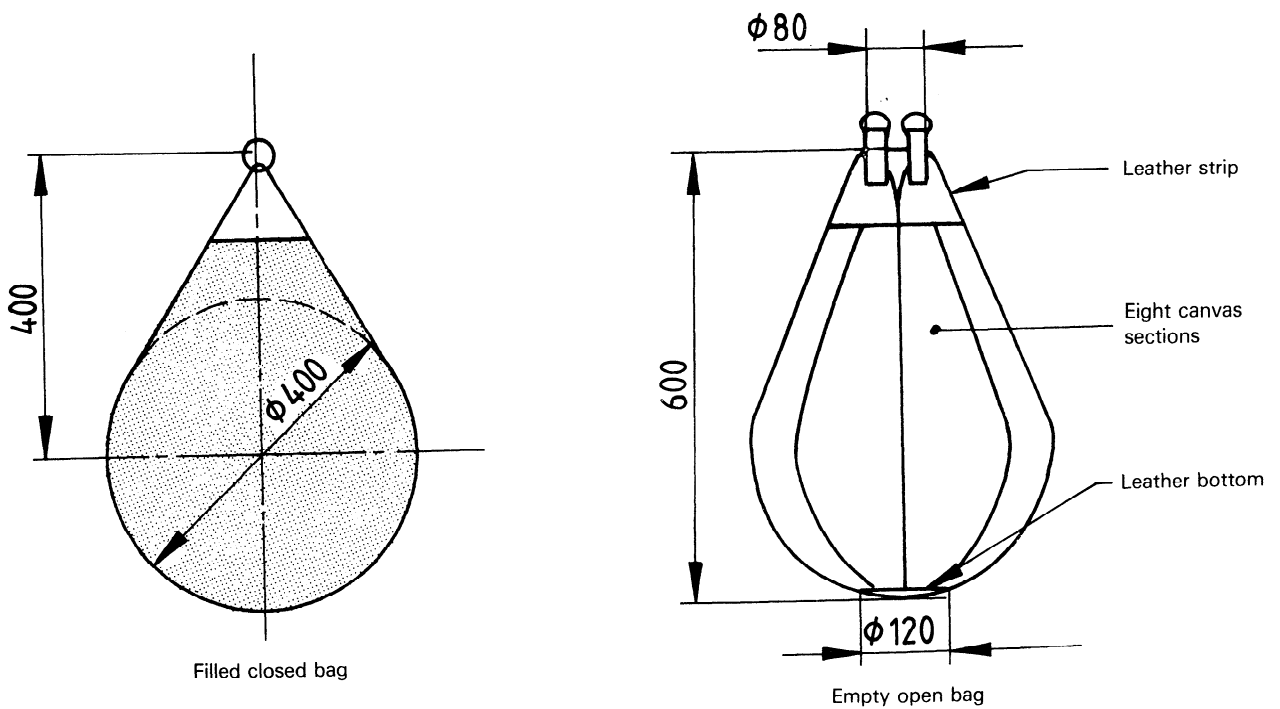

Figure 2 — 50 kg spheroconical bag

Unless otherwise indicated in the test standards specific to each building element, the test shall be performed in such a way that the tangent plane at the point of impact is at right angles to the vertical plane described by the pendular fall of the impact bodies.

### 4.3 Impact from a hard body

**4.3.1** The impact is obtained by the pendular fall of one of the two steel ball-bearings described in 3.1. The device used in order to control the fall of the steel ball-bearing is shown in figure 3.

**4.3.2** The steel ball-bearing is suspended by its ring to a cable  $C_1$  attached to a fixed point on the test apparatus and arranged in place in such a way that

- when in the resting position the steel ball-bearing is tangential to the building element at the predicted point of impact,
- the length of cable  $C_1$  between the ring of the steel ball-bearing and the point at which it is fixed shall be at least equal to 1,75 times the anticipated drop height  $H$ .

**4.3.3** The steel ball-bearing is brought to its starting position by raising it pendularly. This shall be done manually, by means of cable  $C_2$ , taking care that

- the vertical plane defined by the converging cables  $C_1$  and  $C_2$  remains at right angles to the plane of the building element at impact,
- the angle between cable  $C_2$  and the vertical remains between  $30^\circ$  and  $45^\circ$ .

**4.3.4** The steel ball-bearing remains in vertical suspension while being raised. The drop height  $H$  may be determined using a vertical measuring rod standing on horizontal ground with which is measured the difference in the level of a clearly marked horizontal line around the middle of the steel ball-bearing.

Check that height  $H$  is in conformity with the height set down in the standards specific to each building element.

**4.3.5** Once the drop height  $H$  is reached and the steel ball-bearing is motionless, it is allowed to fall pendularly by releasing it.

### 4.4 Impact from a small soft body

The impact is obtained by the pendular fall of the ball described in 3.2. The device to be used in order to control the fall of the bag is shown in figure 3.

The test procedure is identical to the procedure for the test in 4.3 using the 500 g or 1 kg bearing as an impact body.

The drop heights  $H$  are set down in the standards specific to each building element.

### 4.5 Impact from a large soft body

**4.5.1** The impact is obtained by the pendular fall of the spheroconical bag described in 3.3, this being vertical at the starting point. The device to be used in order to control the fall of the bag is shown in figure 4; the pulleys and winches which are used are arranged in the plane described by the fall of the bag.

**4.5.2** The bag is suspended by its ring to a cable  $C_1$  passing through a pulley  $P_1$  which is attached to the frame and arranged in position so that

- when motionless the bag is tangential to the specimen,
- the angle  $\alpha$  between the cable  $C_1$  and the vertical, when the bag is at its starting position, is less than  $65^\circ$ .

**4.5.3** The horizontal positioning of the bag at right angles with the point of impact is obtained

- either by displacing the plane of the suspension system (winches  $T_1$  and  $T_2$ , pulleys  $C_1$  and  $C_2$ ) laterally in relation to the position of the specimen,
- or by positioning the specimen in relation to the plane of the suspension system.

**4.5.4** The vertical positioning of the bag at right angles with the selected point of impact is obtained by winding cable  $C_1$  onto winch  $T_1$ .

**4.5.5** The bag is brought to its starting position by raising it pendularly using the cable  $C_2$  linked to the ring of the bag by means of a snap-hook  $M$  releasable from a distance. The cable  $C_2$  goes through the pulley  $P_2$  and is wound onto winch  $T_2$ .

**4.5.6** The bag remains in vertical suspension while being raised. The drop height  $H$  may be determined using a vertical measuring rod standing on horizontal ground with which is measured the difference in the level of a clearly marked horizontal line around the middle of the bag.

For each element under consideration specific standards set down the drop heights  $H$  and the angle  $\alpha$  between cable  $C_1$  and the vertical.

**4.5.7** The bag falls pendularly when the snap-hook  $M$  is released.

#### NOTES

- 1 When the snap-hook cannot be released from a distance, a wick of a suitable section which may be ignited from a distance may be inserted in the non-winding section of cable  $C_2$ .
- 2 In special experimental cases in which the starting angle  $\alpha$  is more than  $65^\circ$ , the fall of the bag creates oscillations in its falling plane which could result in the impact energy being changed. To avoid these oscillations, the bag should not be released from a vertical position but from an inclined position, the axis of the bag being maintained in the continuation of cable  $C_1$ .

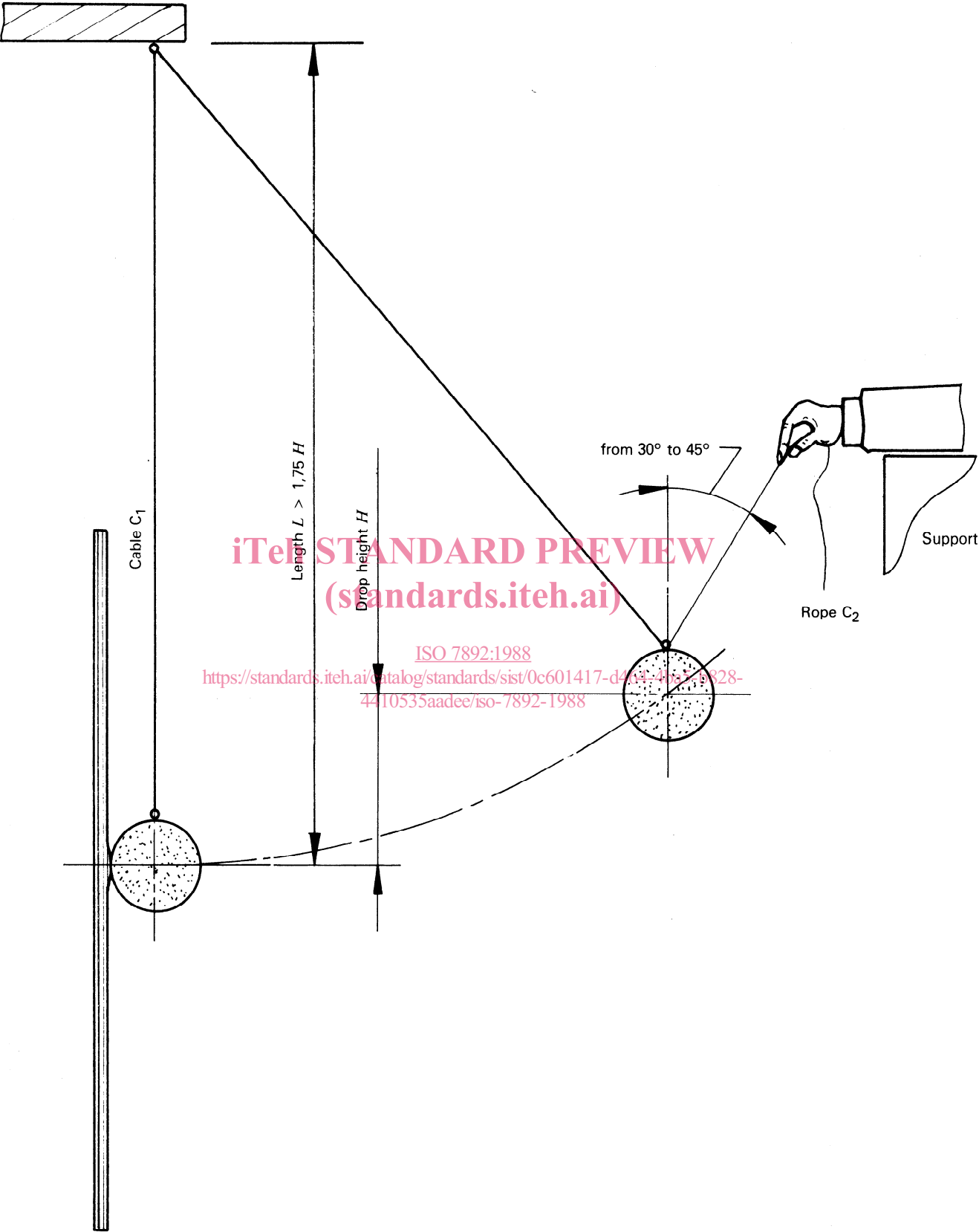

Figure 3 — Example of test apparatus using a small hard impact body

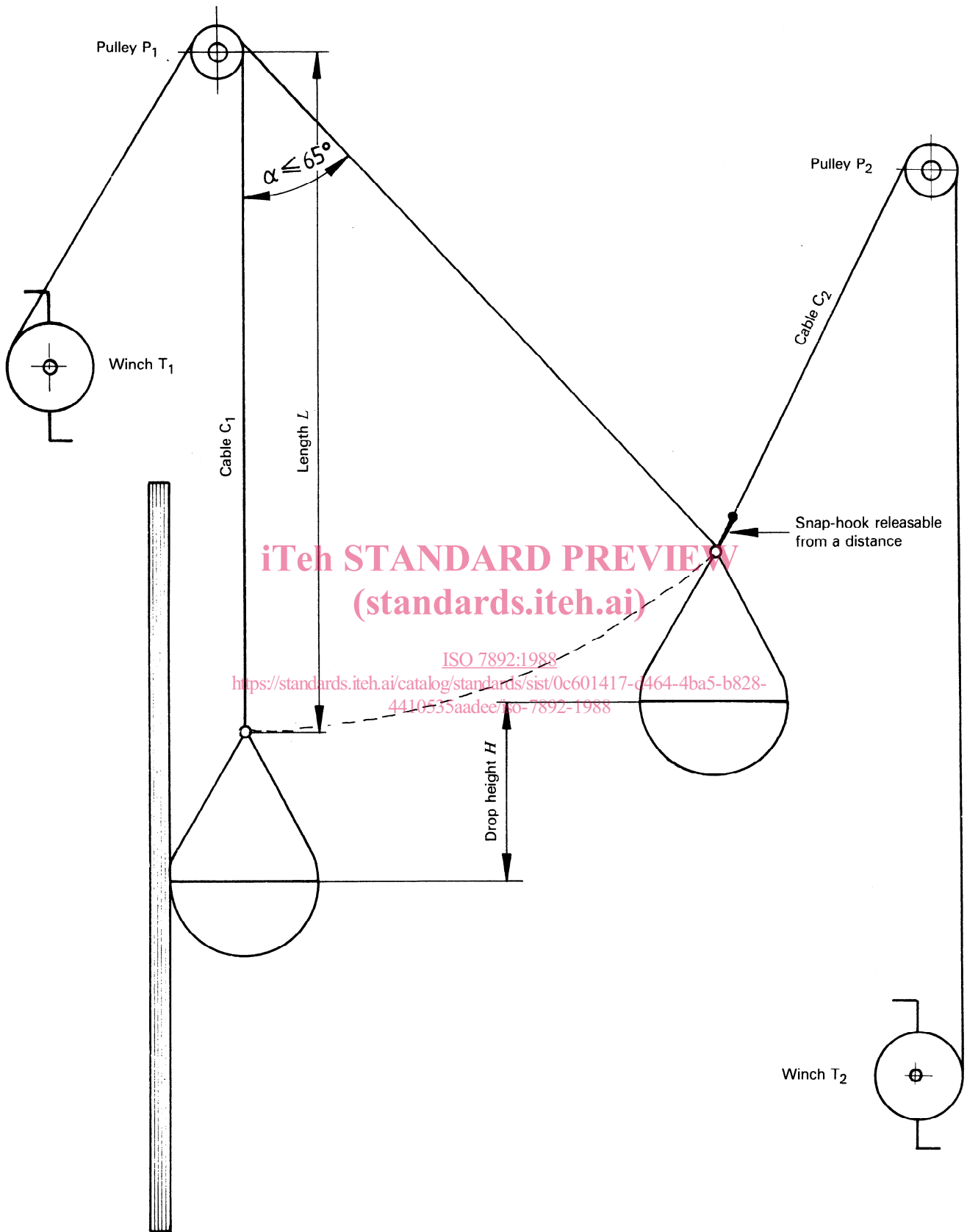

Figure 4 — Example of test apparatus using a large soft impact body



**iTeh STANDARD PREVIEW**  
**(standards.iteh.ai)**

This page intentionally left blank

ISO 7892:1988

<https://standards.iteh.ai/catalog/standards/sist/0c601417-d464-4ba5-b828-4410535aadee/iso-7892-1988>